



**sealmatic®**

**DESIGN MANUAL 2.6**



sealmatic®

## MECHANICAL SEALS FOR

Oil & Gas | Refinery | Petrochemical | Chemical | Power  
Fertiliser | Pharmaceutical | Paper | Aerospace | Marine

[sealmaticindia.com](http://sealmaticindia.com)



## About the Company

Sealmatic designs and manufactures mechanical seals and associated products mainly for the oil & gas, chemical, pharmaceutical, pulp & paper, power, mining and many more industrial applications. Sealmatic can help relieve stress and reduce the life cycle costs associated with the most important aspects of plant operation. Sealmatic has a longstanding tradition of providing mechanical seals and sealing services that are trusted by the industry.

## Sealing Technology

With a wide range of products and services, Sealmatic has solutions for every sealing requirement – such as Pusher Seals, Standard Cartridge Seals, Elastomer Bellows Seals, Metal Bellows Seals, Engineered Seals, Split Seals, Gas-Lubricated Seals and many more. Each and every Sealmatic seal is the result of numerous steps involving extensive engineering and thus processing the same in various production steps. Our engineers at Sealmatic work with discipline and passion to maintain high standards in their respective fields. With the use of 3D modelling we ensure optimum performance of application specific seals. Sealmatic has engineered high-performance products that reliably withstand extreme environments, challenging applications and evolving legislation. No matter how strict the specification or how unique the application, we have the solutions to offer. Extremely complicated seal faces for Dry Gas Seals are manufactured under a controlled environment, deploying sophisticated machines to produce intricate profiles on the seal face.

## Continuous Research & Training

To maintain our position at the forefront of technological innovation, we continuously test our new designs in real-world environments, simulated by our state-of-the-art test rigs. Sealmatic provides a wide range of training courses that cover the correct procedures for installing, operating and maintaining mechanical seals. With a combination of hands on as well as theoretical training, our employees learn about safety, performance, reliability of energy services and industrial process plants including trouble shooting and problem solving, enabling them to become experts in their fields. With the deep knowledge of over 70 subjects and intricate designs, we have built a legacy to carry forward the vision of our company.

## Global Sales & Service

Our aim at Sealmatic is to ensure utmost satisfaction of our customers, where we ensure international quality and close proximity. And because our partners are globally located, we can be present in person anytime, offering engineering services whenever needed. Our customers are spread across all the continents and we are very proud to state that we have 100% retention rate, we have a satisfied base of over 1000 customers across the globe.

## Environmental, Health & Safety

Sealmatic's management and employees take active participation in establishing and supporting Environmental, Health and Safety (EHS) policy and procedures. By maintaining compliance with applicable EHS laws and regulations, Sealmatic strives to ensure the health, safety, and welfare of its employees and others affected by its business operations.





<b>1</b>	<b>Industrial Applications</b>	<b>Page 1-2</b>
<b>2</b>	<b>Standard Cartridge Seals</b>	<b>Page 3-22</b>
<b>3</b>	<b>Mechanical Seals As Per API 682</b>	<b>Page 23-26</b>
<b>4</b>	<b>Split Seals</b>	<b>Page 27-32</b>
<b>5</b>	<b>Engineered Seals For Demanding Applications</b>	<b>Page 33-39</b>
<b>6</b>	<b>Standard Mechanical Seals For Pumps &amp; Compressors</b>	<b>Page 40-66</b>
<b>7</b>	<b>Gas Lubricated Seals for Pumps &amp; Agitators</b>	<b>Page 67-72</b>
<b>8</b>	<b>Mechanical Seals for Agitators, Mixers, Kneaders &amp; Reactors</b>	<b>Page 73-83</b>
<b>9</b>	<b>Supply Systems &amp; Components</b>	<b>Page 84-98</b>
<b>10</b>	<b>Technical Information</b>	<b>Page 99-107</b>

**Disclaimer:**

The specifications, drawings, images etc included in this catalogue are intended to be generic and must be interpreted as equivalent or functionally equivalent. The identification of many items are facilitated by illustrations (photographs and general assembly drawings) and mention of, or reference to any specific standards, or trade names, including those that might appear on the photographs, drawings, images etc is intended for illustration purposes only, and does not imply an endorsement or imitation or preference of any specific standard, brand, manufacturer or supplier. Neither does the information imply the availability of any mentioned items. The items discussed alongwith the images, drawings etc portrayed are representative of industry catalogues, standards, terminology and specifications & hence accounting for any resemblance which otherwise may be co-incidental.

This Catalogue does not contain any guarantee or agreed quality of products or any warranty of merchantability, fitness for a particular purpose and non-infringement. The data and information contained herein are being provided for information only and without responsibility, and Sealmatic India Pvt. Ltd. makes no representations or warranties, either expressed or implied, as to the accuracy, completeness, or fitness for a particular purpose. Sealmatic does not accept any responsibility or liability with regard to the reliance on, or use of this data and information.

Sealmatic is continuously improving and upgrading their products with respect to quality and application and therefore any changes made to the catalogue may be made without any notice.

# Industrial Applications

## Onshore



To be able to cope with sand, water and gases found in crude oil, pumping systems for mineral oil require heavy duty pumps with reliable engineered mechanical seals that feature durable sliding faces with good emergency running characteristics. Often it is necessary to seal pressures in excess of 100 bar and sliding velocities of over 60 m/s. The ideal seal face combination for such conditions have proven to be high-strength carbons running against silicon carbide.

### Typical Applications

- Crude Oil Pump
- Pipeline Pump
- Water Injection Pump

## Offshore



Adverse environmental conditions, high rotational speed and pressure levels as well as corrosive media constituents place demanding requirements on sealing technology used in the offshore production and subsequent conveyance of oil and gas. Not only that but in many cases highly abrasive mixtures of crude oil, water, gas and sand cause a high degree of wear. Sealmatic has proven itself with its heavy-duty mechanical seals with innovative and tailor made seal components with high-strength seal faces, guaranteeing longer service life even in highly stressed pumps.

### Typical Applications

- Main Oil Export Pump
- Multiphase Pump
- Water Injection Pump

## Compressors



High speed machines whose trouble free availability constitutes a major precondition for many process engineering operations. Key criteria for the selection and design of compressors are the working medium, the compression ratio, the volume flow, the number of intermediate inputs & outputs and the design of the shaft seal which assumes critical importance.

### Typical Applications

- Ammonia Compressor
- CO Compressor
- Oven Gas Compressor
- Ethylene Compressor
- Flash Turbine
- Screw Compressor

## Quarrying & Coal Mining



The cutter heads on quarrying and mining machines are fed with water, not only for cooling purposes but also for settling the dust and extinguishing any sparks produced by the cutting tools. Mechanical Seals perform the dual function of a rotary joint and a seal for the cutter and roller heads. Sealing systems used on these equipment are exposed to abrasive and chemically aggressive media. In some applications, high temperature and pressure make conditions even more challenging. Despite the harsh operating environment, users expect high reliability to avoid costly downtime.

### Typical Applications

- Cutter Head Seal
- Mining Machine
- Roller Head Seal
- Rotary Joint For Carbide Cutter

## Coal Gasification



There were times, particularly during the oil-crisis years, when coal gasification centered on the process of hydrogenation, e.g. to produce motor fuels. Nowadays the driving force behind its further development is the generation of electricity by combination-type power stations with integrated coal gasification. Here the main objectives are to lower CO2 emissions, to raise fuel efficiency and to stretch existing resources.

### Typical Applications

- Coal Feed Screw

## Chemical & Petrochemical



The materials used in the chemical/petrochemical industry need to be capable of coping with the large array of media, many of them explosive or toxic and others which could become when mixed. An increased awareness of environmental risks calls for a maximum reliability and operational safety, especially from sealing systems. Against this background, the sealing systems used in applications involving what are in many cases explosive, toxic or aggressive media have to ensure optimum tightness. On the other hand they should also help optimize processes and thus be of advantage where the economic aspects are concerned as well. From non-critical sealing points – for which standard solutions are deployed – right through to highly complex system solutions required where particularly difficult operating conditions are concerned.

### Typical Applications

- Agitator Bead Mill
- Chemical Pump
- Eccentric Screw Pump
- Gear Pump
- Glass Lined Reactor
- Thin Film Evaporator
- Centrifuge
- Chemical Reactor

# Industrial Applications

## Refinery



The processing of crude oil in refineries is a complex and multi-stage process in which crude oil is transformed into refined, high-quality end products or feed materials for petrochemical industry. Sealing technology for such diverse applications have to meet challenges in various respects; risk of insufficient lubrication and dry running, media with a diversity of physical properties, high and low temperature ranges and the handling of hazardous substances and all other conditions which need to be controlled with absolute reliability. With a comprehensive range of API-compliant quality seals and supply systems, Sealmatic is playing a key role towards ensuring the reliability and safety of refinery processes.

### Typical Applications

- Discharge Pump
- Gas Oil Pump
- GLP Delivery Pump
- Quench Oil Pump
- Residual Oil Pump

## Sugar



Sugar campaigns are over in a relatively short time. For optimum economy and ecology it is all the more important, therefore to have a reliable sealing systems. In the past it was normal for juice pumps to be equipped with double seals to cope with the tendency to crystallization and carbonation. Today the use of single seals is possible in most of the cases due to availability of modern materials and new seal compartment geometries.

### Typical Applications

- Flume Water Pump
- Juice Circulating Pump
- Worm Agitator
- Mash Pump

## Pharmaceutical



In addition to meeting technical requirements a seal has to display many other characteristics in connection with cleanliness, health and general legislation. These include for example materials which are compatible with food, smooth and abrasion-proof surfaces which are easy to clean, complete units which can be sterilized and cleaned without having to be dismantled (SIP/CIP). Sealmatic mechanical seals have been used for such demanding applications with great success in sterile processes. Our range of mechanical seals includes a broad spectrum of high-quality, specifically optimized sealing solutions ranging from standard solutions to specialized system solutions for nearly any application in the pharmaceutical industry.

### Typical Applications

- Agglomerator
- Spherical Dryer
- Eccentric Pump
- Sterile Pump
- Centrifugal Pump
- Filter Dryer
- Food Pump

## Power



Sealing systems featuring maximum operational reliability, convenient maintenance and low leakage rates with necessary environmental protective measures are standard requirements in modern power stations. The product range includes mechanical seals and supply systems for auxiliary and secondary pumps, boiler circulation pumps and feedwater pumps as well as mechanical seals and carbon floating ring seals for turbines, compressors and fans.

### Typical Applications

- Boiler Circulating Pump
- Feed Pump
- Flue Gas Desulphurisation
- Residue Evacuation Pump
- Condensate Pump

## Pulp & Paper



Wood is the most important raw material for the pulp and paper industry. It is either digested to chemical pulp in digesters or reduced to mechanical pulp in grinders or refiners. The pulp produced this way is then graded, bleached and washed and conveyed to the paper machine. There it passes through the various stages such as head box, wire part, press section, drying section and reeling section.

### Typical Applications

- Pressure Grinder
- Pulp Pump
- Digesting & Bleaching Pump
- Deinking Pump

## Hot water

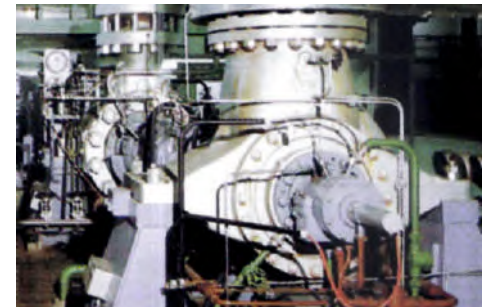

Hot water is conveyed by pumps for a variety of purposes in thermal energy generating systems, district heating systems, home heating systems and so on. The suitability of a mechanical seal for such applications depends on many different parameters, e.g. pressure to be sealed, temperature at the seal, sliding velocity, power consumption, water quality (pH-value, O<sub>2</sub>-dose, conductivity, operating mode), water additives such as corrosion inhibitors etc.

# CTX ANSI Single Seals

# Standard Cartridge Seals



## Product Description

1. Single seal configuration
2. Balanced design
3. Independent of direction of rotation
4. Cartridge construction
5. Available for standard (CTX-ASPN) and big bore (CTX-ABPN) seal chambers
6. Single seals with flush (-ASPN, -ABPN) and with quench combined with lip seal (-ASQN, -ABQN) or throttle ring (-ASTN, -ABTN)

## Technical Features

1. Ideal for use in ANSI process pumps
2. O-ring is dynamically loaded to prevent shaft damage.
3. Dimensional modification of the stuffing box chamber is not required due to short radial installation height
4. Ideal to convert and retrofit pumps with packings and large volume OEM production
5. Cartridge unit factory assembled for easy installation, which reduces downtime
6. Rugged design for long operating life

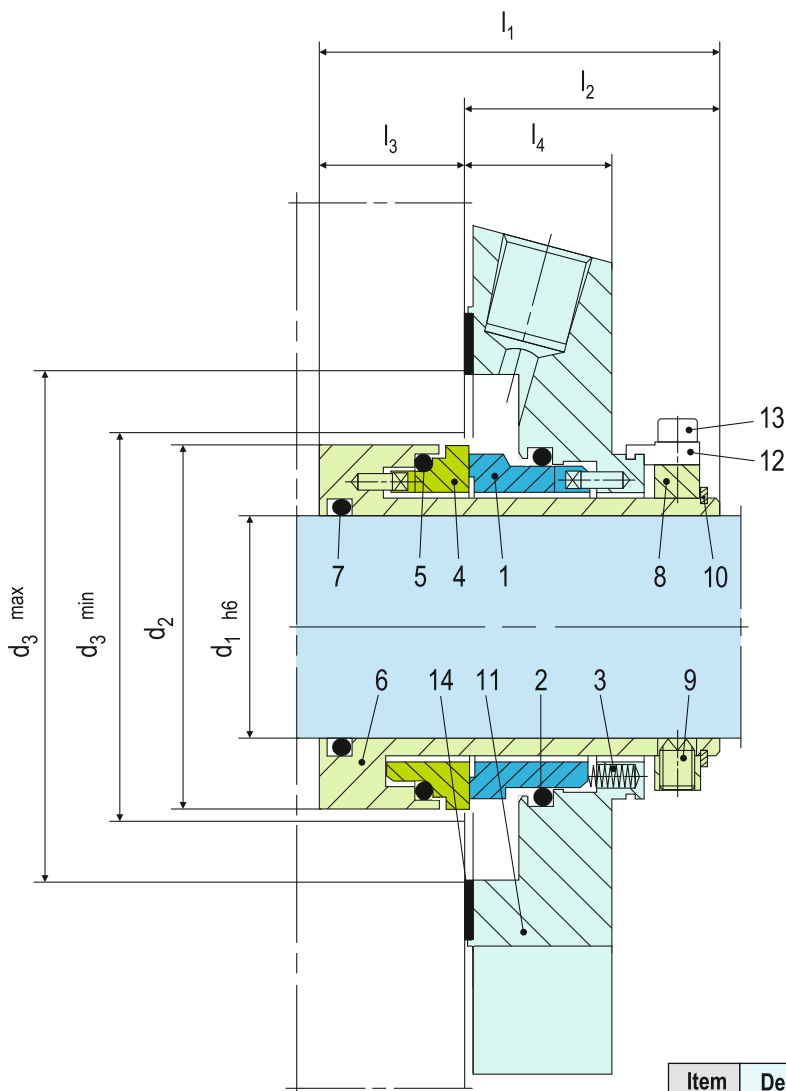

Note: The item numbers as depicted above are based on our technical experience and knowledge and are placed in the chronological order of their assembly procedure.

Item	Description
1	Seal face
2, 5, 7	O-ring
3	Spring
4	Seat
6	Shaft sleeve
8	Drive collar
9	Set screw

## Typical Industrial Applications

ANSI process pumps  
 Chemical industry  
 Food and beverage industry  
 Petrochemical industry  
 Pharmaceutical industry  
 Universally applicable  
 Water and waste water technology

## Standards

ANSI

## Materials

Seal face: Silicon carbide (Q1), Carbon graphite resin impregnated (B), Tungsten carbide (U2)  
 Seat: Silicon carbide (Q1)  
 Secondary seals: FKM (V), EPDM (E), FFKM (K), Perfluorocarbon rubber/PTFE (U1)  
 Springs: Hastelloy® C-4 (M)  
 Metal parts: CrNiMo steel (G), CrNiMo cast steel (G)

## Performance Capabilities

CTX-ASPN, -ABPN, -ASTN, -ABTN, -ASQN, -ABQN  
 Sizes:  $d_1 = 1.000'' \dots 3.750''$

Other sizes on request

Temperature:  $t = -40^\circ\text{C} \dots +220^\circ\text{C} (-40^\circ\text{F} \dots +428^\circ\text{F})$   
 (Check O-ring resistance)

### Sliding face material combination BQ1

Pressure:  $p_1 = 25 \text{ bar (363 PSI)}$

Speed = 16 m/s (52 ft/s)

### Sliding face material combination Q1Q1 or U2Q1

Pressure:  $p_1 = 12 \text{ bar (175 PSI)}$

Speed = 10 m/s (33 ft/s)

Permissible axial movement:  $\pm 1.0 \text{ mm}, d_1 \geq 75 \text{ mm}$   
 $\pm 1.5 \text{ mm}$

Item	Description
10	Snap ring
11	Cover
12	Assembly fixture (remove after installation)
13	HSH Cap Screw
14	Gasket
16	Lip seal (-QN), throttle ring (-TN)

### Installation, Details, Options

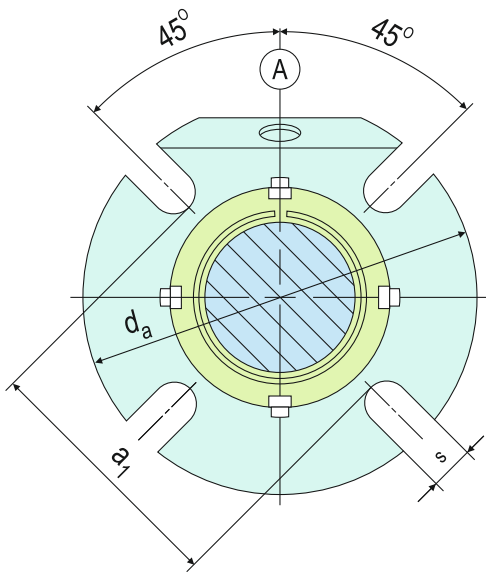

### Product Variants

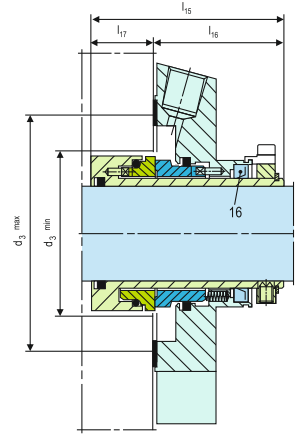
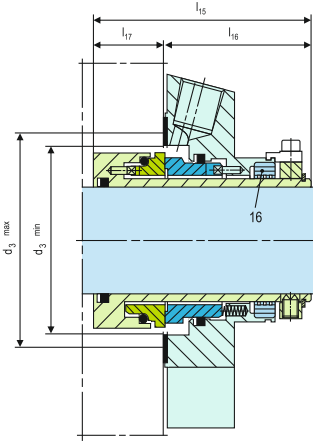

#### CTX-ASTN and -ABTN

Single seal for operation with unpressurized quench for standard (S) and big bore (B) seal chambers. Same as CTX-ASPN and -ABPN but with throttle ring (item 16). The cover has auxiliary connections for flushing and quench. Throttle ring: PTFE carbongraphite reinforced (T12).

#### CTX-ASQN and -ABQN

Single seal for operation with unpressurized quench for standard (S) and big bore (B) seal chambers. Same as CTX-ASPN and -ABPN version but with lip seal (item 16) at the atmospheric side. The cover has auxiliary connections for flushing and quench. Lip seal: NBR (P), FKM (V), PTFE carbon reinforced (T3)

### Dimensional Data

#### BIG BORE : Dimensions in inch

d <sub>1</sub>	d <sub>2</sub>	d <sub>3</sub> min	d <sub>3</sub> max	l <sub>1</sub>	l <sub>2</sub>	l <sub>3</sub>	l <sub>4</sub>	l <sub>5</sub>	l <sub>6</sub>	l <sub>7</sub>	a <sub>1</sub>	d <sub>a</sub>	s	Connection
1.000	-	-	-	-	-	-	-	-	-	-	-	-	-	-
1.125	1.713	1.752	2.795	2.638	1.669	0.969	1.000	2.937	1.909	1.028	3.311	4.500	0.437	1/4 NPT
1.250	-	-	-	-	-	-	-	-	-	-	-	-	-	-
1.375	1.960	2.000	3.189	2.638	1.669	0.969	1.000	2.947	1.919	1.028	3.543	5.118	0.437	1/4NPT
1.500	-	-	-	-	-	-	-	-	-	-	-	-	-	-
1.625	-	-	-	-	-	-	-	-	-	-	-	-	-	-
1.750	2.461	2.500	4.055	2.638	1.669	0.969	1.000	3.012	1.984	1.028	4.567	6.496	0.559	3/8 NPT
1.875	2.583	2.661	3.937	2.638	1.669	0.969	1.000	3.071	2.059	1.012	4.409	5.984	0.551	3/8 NPT
2.000	2.677	2.756	4.567	2.638	1.929	0.709	1.000	3.130	2.102	1.028	4.882	6.260	0.551	3/8 NPT
2.125	2.834	2.913	4.528	2.638	1.945	0.639	1.276	3.012	1.984	1.028	5.276	6.890	0.709	3/8 NPT
2.250	2.960	3.093	4.409	2.638	1.945	0.693	1.276	3.130	2.102	1.028	4.685	6.417	0.709	3/8 NPT
2.500	3.212	3.299	5.276	2.638	1.919	0.719	1.250	3.130	2.102	1.028	5.512	7.795	0.709	3/8 NPT
2.625	3.338	3.170	5.118	2.638	1.919	0.719	1.250	3.130	2.102	1.028	5.354	6.890	0.709	3/8 NPT
2.750	3.660	3.740	5.236	2.638	1.945	0.693	1.276	3.130	2.102	1.028	5.512	7.480	0.630	3/8 NPT
3.000	3.937	4.016	5.512	3.307	2.276	1.031	1.276	3.858	2.516	1.343	5.906	8.228	0.650	3/8 NPT
3.250	-	-	-	-	-	-	-	-	-	-	-	-	-	-

#### STANDARD BORE : Dimensions in inch

d <sub>1</sub>	d <sub>2</sub>	d <sub>3</sub> min	d <sub>3</sub> max	l <sub>1</sub>	l <sub>2</sub>	l <sub>3</sub>	l <sub>4</sub>	l <sub>5</sub>	l <sub>6</sub>	l <sub>7</sub>	a <sub>1</sub>	d <sub>a</sub>	s	Connection
1.000	1.693	1.732	2.205	2.638	1.669	0.969	1.000	2.937	1.909	1.028	2.756	3.937	0.433	1/4 NPT
1.125	1.713	1.752	2.205	2.638	1.669	0.969	1.000	2.937	1.909	1.028	2.440	4.134	0.437	1/4 NPT
1.250	1.969	2.008	2.402	2.638	1.669	0.969	1.000	3.130	2.102	1.028	2.638	4.252	0.433	1/4 NPT
1.375	1.961	2.000	2.402	2.638	1.669	0.969	1.000	2.947	1.919	1.028	2.760	4.213	0.437	1/4 NPT
1.500	2.200	2.244	2.717	2.638	1.669	0.969	1.000	3.130	2.102	1.028	2.950	4.488	0.551	3/8 NPT
1.625	2.340	2.421	2.795	2.638	1.669	0.969	1.000	3.130	2.102	1.028	3.030	4.921	0.551	3/8 NPT
1.750	2.461	2.500	2.953	2.638	1.669	0.969	1.000	3.012	1.984	1.028	3.228	5.118	0.559	3/8 NPT
1.875	2.583	2.661	3.070	2.638	1.669	0.969	1.000	3.071	2.043	1.028	3.190	5.118	0.551	3/8 NPT
2.000	2.677	2.756	3.189	2.638	1.669	0.969	1.000	3.130	2.102	1.028	3.430	5.472	0.630	3/8 NPT
2.125	2.834	2.913	3.583	2.638	1.669	0.969	1.000	3.012	1.984	1.028	3.820	5.512	0.650	3/8 NPT
2.250	2.960	3.039	3.583	2.638	1.669	0.969	1.000	3.130	2.102	1.028	3.858	5.866	0.650	3/8 NPT
2.375	3.070	3.125	3.590	2.638	1.669	0.969	1.000	-	-	-	4.020	6.181	0.709	3/8 NPT
2.500	3.212	3.291	3.937	2.638	1.669	0.969	1.000	3.130	2.102	1.028	4.528	6.693	0.709	3/8 NPT
2.625	3.338	3.417	4.016	2.638	1.669	0.969	1.000	3.130	2.102	1.028	4.528	6.378	0.630	3/8 NPT
2.750	3.660	3.740	4.370	2.638	1.929	0.709	1.260	3.130	2.102	1.028	4.646	7.480	0.709	3/8 NPT
3.000	3.937	4.016	4.724	3.307	2.260	1.047	1.000	3.858	2.516	1.343	5.000	7.835	0.709	3/8 NPT
3.250	4.189	4.268	4.921	3.307	2.260	1.047	1.000	3.858	2.516	1.343	5.315	7.830	0.709	3/8 NPT
3.750	4.689	4.750	5.433	3.307	2.260	1.047	1.000	-	-	-	5.827	8.189	0.866	3/8 NPT

Note: Additional technical & dimensional information will be provided on request.

The specifications, drawings, images etc included in this catalogue are intended to be generic and must be interpreted as equivalent or functionally equivalent, more specifically the performance capabilities mentioned in this catalogue is based on optimum values, however the performance of the product is dependent on size, material of construction, media, pressure, temperature, sliding velocity etc and it shall vary from size to size or application to application. Customers are requested to consult with Sealmatic before employing the product from this catalogue for any application.

# CTX Single Seals

# Standard Cartridge Seals



## Product Description

1. Single seal configuration
2. Balanced design
3. Independent of direction of rotation
4. Cartridge construction

## Technical Features

1. Ideal for use in process pump standardization
2. O-ring is dynamically loaded to prevent shaft damage.
3. Dimensional modification of the stuffing box chamber is not required due to short radial installation height
4. Ideal to convert and retrofit pumps with packings and large volume OEM production
5. Cartridge unit factory assembled for easy installation, which reduces down-time
6. Rugged design for long operating life

## Typical Industrial Applications

Chemical industry  
 Food and beverage industry  
 Petrochemical industry  
 Pharmaceutical industry  
 Universally applicable  
 Water and waste water technology  
 Centrifugal pumps  
 Eccentric screw pumps  
 Process pumps

## Materials

Seal face: Silicon carbide (Q1), Carbon graphite resin impregnated (B), Tungsten carbide (U2)  
 Seat: Silicon carbide (Q1)  
 Secondary seals: FKM (V), EPDM (E), FFKM (K), Perfluorocarbon rubber/PTFE (U1)  
 Springs: Hastelloy® C-4 (M)  
 Metal parts: CrNiMo steel (G), CrNiMo cast steel (G)

## Performance Capabilities

CTX-SN, -SNO, -QN, -TN  
 Sizes:  $d_1 =$  Upto 100 mm (Upto 4.000")  
 Other sizes on request  
 Temperature:  $t = -40^\circ\text{C} \dots +220^\circ\text{C}$   
 ( $-40^\circ\text{F} \dots +428^\circ\text{F}$ )  
 (Check O-ring resistance)  
**Sliding face material combination BQ1**  
 Pressure:  $p_1 = 25$  bar (363 PSI)  
 Speed = 16 m/s (52 ft/s)  
**Sliding face material combination Q1Q1 or U2Q1**  
 Pressure:  $p_1 = 12$  bar (175 PSI)  
 Speed = 10 m/s (33 ft/s)  
 Permissible axial movement:  $\pm 1.0$  mm,  $d_1 \geq 75$  mm  $\pm 1.5$  mm

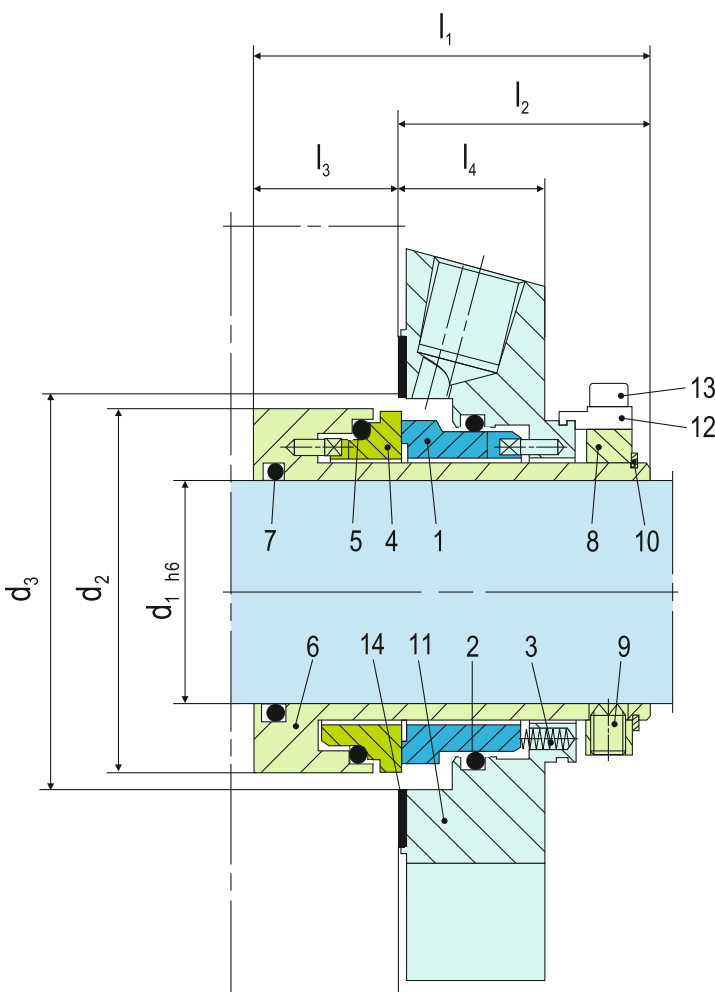

Note: The item numbers as depicted above are based on our technical experience and knowledge and are placed in the chronological order of their assembly procedure.

Item	Description
1	Seal face
2, 5, 7	O-ring
3	Spring
4	Seat
6	Shaft sleeve
8	Drive collar
9	Set screw

Item	Description
10	Snap ring
11	Cover
12	Assembly fixture
13	HSH Cap Screw
14	Gasket
16	Lip seal (-QN), throttle ring (-TN)



### Installation, Details, Options

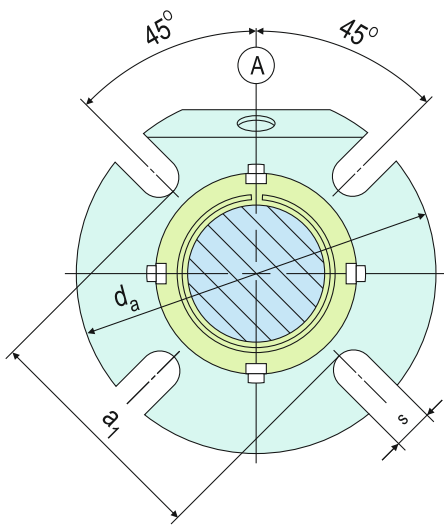

### Design Variations

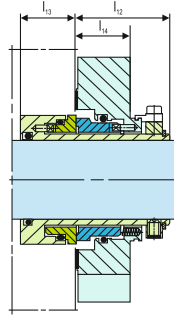

#### CTX-SNO

Single seal without connections, for dead-end operation.

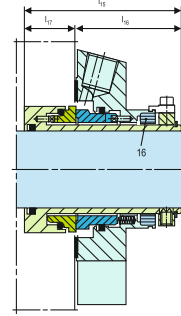

#### CTX-TN

Single seal for operation with unpressurized quench. Same as CTX-SN but with throttle ring (item 16). The cover has auxiliary connections for flushing and quench.

Throttle ring: PTFE carbon-graphite reinforced (T12).

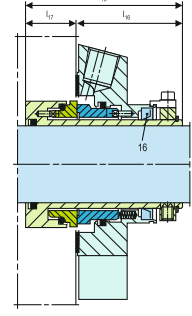

#### CTX-QN

Single seal for operation with unpressurized quench. Same as "-SN" version but with outboard lip seal (item 16). The cover has auxiliary connections for flushing and quench.

Lip seal: NBR (P), FKM (V), PTFE carbon reinforced (T3).

### Dimensional Data

#### Dimensions in inch

d <sub>1</sub>	d <sub>2</sub>	d <sub>3min.</sub>	d <sub>3max.</sub>	l <sub>1</sub>	l <sub>2</sub>	l <sub>3</sub>	l <sub>4</sub>	l <sub>12</sub>	l <sub>13</sub>	l <sub>14</sub>	l <sub>15</sub>	l <sub>16</sub>	l <sub>17</sub>	a <sub>1</sub>	d <sub>a</sub>	s	Connection
1.000	1.693	1.750	2.000	2.640	1.669	0.969	1.000	1.378	1.260	0.689	3.130	2.102	1.028	2.440	4.134	0.520	1/4 NPT
1.125	1.811	1.875	2.050	2.640	1.669	0.969	1.000	1.378	1.260	0.689	3.130	2.102	1.028	2.440	4.134	0.520	1/4 NPT
1.250	1.969	2.008	2.244	2.640	1.669	0.969	1.000	1.378	1.260	0.689	3.130	2.102	1.028	2.640	4.252	0.520	1/4 NPT
1.375	2.086	2.125	2.420	2.640	1.669	0.969	1.000	1.378	1.260	0.689	3.130	2.102	1.028	2.750	4.449	0.520	1/4 NPT
1.500	2.200	2.250	2.625	2.640	1.669	0.969	1.000	1.378	1.260	0.689	3.130	2.102	1.028	2.950	4.842	0.520	3/8 NPT
1.625	2.340	2.375	2.700	2.640	1.669	0.969	1.000	1.378	1.260	0.689	3.130	2.102	1.028	3.030	4.842	0.599	3/8 NPT
1.750	2.460	2.500	2.812	2.640	1.669	0.969	1.000	1.378	1.260	0.689	3.130	2.102	1.028	3.190	5.433	0.599	3/8 NPT
1.875	2.582	2.625	2.940	2.640	1.669	0.969	1.000	1.378	1.260	0.689	3.130	2.102	1.028	3.307	5.433	0.599	3/8 NPT
2.000	2.677	2.750	3.190	2.640	1.669	0.969	1.000	1.378	1.260	0.689	3.130	2.102	1.028	3.430	5.827	0.599	3/8 NPT
2.125	2.834	2.875	3.437	2.640	1.669	0.969	1.000	1.378	1.260	0.689	3.130	2.102	1.028	3.543	5.827	0.709	3/8 NPT
2.250	2.960	3.000	3.560	2.640	1.669	0.969	1.000	1.378	1.260	0.689	3.130	2.102	1.028	3.940	6.181	0.709	3/8 NPT
2.375	3.070	3.125	3.590	2.640	1.669	0.969	1.000	1.378	1.260	0.689	3.130	2.102	1.028	4.020	6.181	0.709	3/8 NPT
2.500	3.212	3.250	3.800	2.640	1.669	0.969	1.000	1.378	1.260	0.689	3.130	2.102	1.028	4.170	6.417	0.709	3/8 NPT
2.625	3.338	3.375	3.937	2.640	1.669	0.969	1.000	1.378	1.260	0.689	3.130	2.102	1.028	4.290	6.417	0.709	3/8 NPT
2.750	3.660	3.750	4.250	2.640	1.669	0.969	1.000	1.378	1.260	0.689	3.130	2.102	1.028	4.650	7.008	0.709	3/8 NPT
2.875	3.937	4.000	4.646	3.307	2.260	1.047	1.000	1.815	1.492	0.866	-	-	-	5.079	7.480	0.709	3/8 NPT
3.000	3.937	4.000	4.646	3.307	2.260	1.047	1.000	1.815	1.492	0.866	3.858	2.516	1.343	5.039	7.480	0.709	3/8 NPT
3.125	4.190	4.125	4.764	3.307	2.260	1.047	1.000	1.815	1.492	0.866	3.858	2.516	1.343	5.315	7.677	0.709	3/8 NPT
3.250	4.189	4.250	4.882	3.307	2.260	1.047	1.000	1.815	1.492	0.866	-	-	-	5.315	7.677	0.709	3/8 NPT
3.375	4.311	4.375	5.039	3.307	2.260	1.047	1.000	1.815	1.492	0.866	-	-	-	5.472	7.795	0.866	3/8 NPT
3.500	4.437	4.500	5.157	3.307	2.260	1.047	1.000	1.815	1.492	0.866	-	-	-	5.591	7.795	0.866	3/8 NPT
3.625	4.563	4.625	5.315	3.307	2.260	1.047	1.000	1.815	1.492	0.866	-	-	-	5.709	8.071	0.866	3/8 NPT
3.750	4.689	4.750	5.433	3.307	2.260	1.047	1.000	1.815	1.492	0.866	3.858	2.516	1.343	5.827	8.189	0.866	3/8 NPT
4.000	4.937	5.000	5.669	3.307	2.260	1.047	1.000	1.815	1.492	0.866	-	-	-	6.063	8.583	0.866	3/8 NPT

#### Dimensions in millimeter

d <sub>1</sub>	d <sub>2</sub>	d <sub>3min.</sub>	d <sub>3max.</sub>	l <sub>1</sub>	l <sub>2</sub>	l <sub>3</sub>	l <sub>4</sub>	l <sub>12</sub>	l <sub>13</sub>	l <sub>14</sub>	l <sub>15</sub>	l <sub>16</sub>	l <sub>17</sub>	a <sub>1</sub>	d <sub>a</sub>	s	Connection
25	43.0	44.0	51.5	67	42.4	24.6	25.4	35.0	32.0	17.5	79.5	53.4	26.1	62	105	13.2	1/4 NPT
28	46.0	47.0	52.0	67	42.4	24.6	25.4	35.0	32.0	17.5	79.5	53.4	26.1	62	105	13.2	1/4 NPT
30	48.0	49.0	56.0	67	42.4	24.6	25.4	35.0	32.0	17.5	79.5	53.4	26.1	65	105	13.2	1/4 NPT
32	50.0	51.0	57.0	67	42.4	24.6	25.4	35.0	32.0	17.5	79.5	53.4	26.1	67	108	13.2	1/4 NPT
33	50.0	51.0	57.0	67	42.4	24.6	25.4	35.0	32.0	17.5	79.5	53.4	26.1	67	108	13.2	1/4 NPT
35	53.0	54.0	61.5	67	42.4	24.6	25.4	35.0	32.0	17.5	79.5	53.4	26.1	70	113	13.2	1/4 NPT
38	56.0	57.0	66.0	67	42.4	24.6	25.4	35.0	32.0	17.5	79.5	53.4	26.1	75	123	14.2	3/8 NPT
40	58.0	59.0	68.0	67	42.4	24.6	25.4	35.0	32.0	17.5	79.5	53.4	26.1	75	123	14.2	3/8 NPT
42	60.5	61.5	69.5	67	42.4	24.6	25.4	35.0	32.0	17.5	79.5	53.4	26.1	79	133	14.2	3/8 NPT
43	60.5	61.5	70.5	67	42.4	24.6	25.4	35.0	32.0	17.5	79.5	53.4	26.1	79	133	14.2	3/8 NPT
45	62.5	64.0	73.0	67	42.4	24.6	25.4	35.0	32.0	17.5	79.5	53.4	26.1	81	138	14.2	3/8 NPT
48	65.6	67.0	75.0	67	42.4	24.6	25.4	35.0	32.0	17.5	79.5	53.4	26.1	84	138	14.2	3/8 NPT
50	68.0	69.0	78.0	67	42.4	24.6	25.4	35.0	32.0	17.5	79.5	53.4	26.1	87	148	18.0	3/8 NPT
53	72.0	73.0	87.0	67	42.4	24.6	25.4	35.0	32.0	17.5	79.5	53.4	26.1	97	148	18.0	3/8 NPT
55	73.0	74.0	83.0	67	42.4	24.6	25.4	35.0	32.0	17.5	79.5	53.4	26.1	90	148	18.0	3/8 NPT
60	78.0	79.0	91.0	67	42.4	24.6	25.4	35.0	32.0	17.5	79.5	53.4	26.1	102	157	18.0	3/8 NPT
65	83.1	84.5	98.5	67	42.4	24.6	25.4	35.0	32.0	17.5	79.5	53.4	26.1	109	163	18.0	3/8 NPT
70	93.0	95.0	108.0	67	42.4	24.6	25.4	35.0	32.0	17.5	79.5	53.4	26.1	118	178	18.0	3/8 NPT
75	100.0	101.6	118.0	84	57.4	26.6	25.4	46.1	37.9	22.0	98.0	63.9	34.1	129	190	18.0	3/8 NPT
80	106.4	108.0	124.0	84	57.4	26.6	25.4	46.1	37.9	22.0	98.0	63.9	34.1	135	195	18.0	3/8 NPT
85	109.5	111.1	128.0	84	57.4	26.6	25.4	46.1	37.9	22.0	98.0	63.9	34.1	139	198	22.0	3/8 NPT
90	115.9	117.5	135.0	84	57.4	26.6	25.4	46.1	37.9	22.0	98.0	63.9	34.1	145	205	22.0	3/8 NPT
95	119.1	120.7	138.0	84	57.4	26.6	25.4	46.1	37.9	22.0	98.0	63.9	34.1	148	208	22.0	3/8 NPT
100	125.4	127.0	144.0	84	57.4	26.6	25.4	46.1	37.9	22.0	98.0	63.9	34.1	154	218	22.0	3/8 NPT

Note: Additional technical & dimensional information will be provided on request.

The specifications, drawings, images etc included in this catalogue are intended to be generic and must be interpreted as equivalent or functionally equivalent, more specifically the performance capabilities mentioned in this catalogue is based on optimum values, however the performance of the product is dependent on size, material of construction, media, pressure, temperature, sliding velocity etc and it shall vary from size to size or application to application. Customers are requested to consult with Sealmatic before employing the product from this catalogue for any application.

# CTX ANSI Dual Seals

# Standard Cartridge Seals

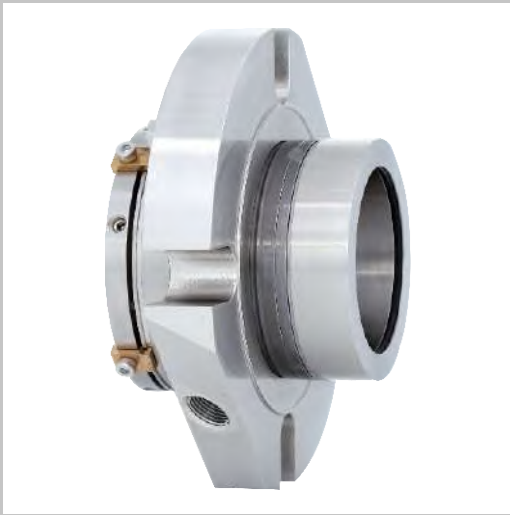

### Product Description

1. Dual seal configuration
2. Balanced design
3. Independent of direction of rotation
4. Cartridge construction
5. Available for standard (CTX-ASDN) and big bore (CTX-ABDN) seal chambers
6. Double pressure balanced
7. Designed with integrated pumping device for increased efficiency in circulation

### Technical Features

1. Ideal for use in ANSI process pumps
2. O-ring is dynamically loaded to prevent shaft damage.
3. Dimensional modification of the stuffing box chamber is not required due to short radial installation height
4. Ideal to convert and retrofit pumps with packings and large volume OEM production
5. Cartridge unit factory assembled for easy installation, which reduces downtime
6. Rugged design for long operating life

### Typical Industrial Applications

ANSI process pumps  
 Chemical industry  
 Food and beverage industry  
 Petrochemical industry  
 Pharmaceutical industry  
 Universally applicable  
 Water and waste water technology

### Standards

ANSI

### Materials

Seal face: Silicon carbide (Q1), Carbon graphite resin impregnated (B), Tungsten carbide (U2)  
 Seat: Silicon carbide (Q1)  
 Secondary seals: FKM (V), EPDM (E), FFKM (K), Perfluorocarbon rubber/PTFE (U1)  
 Springs: Hastelloy® C-4 (M)  
 Metal parts: CrNiMo steel (G), CrNiMo cast steel (G)

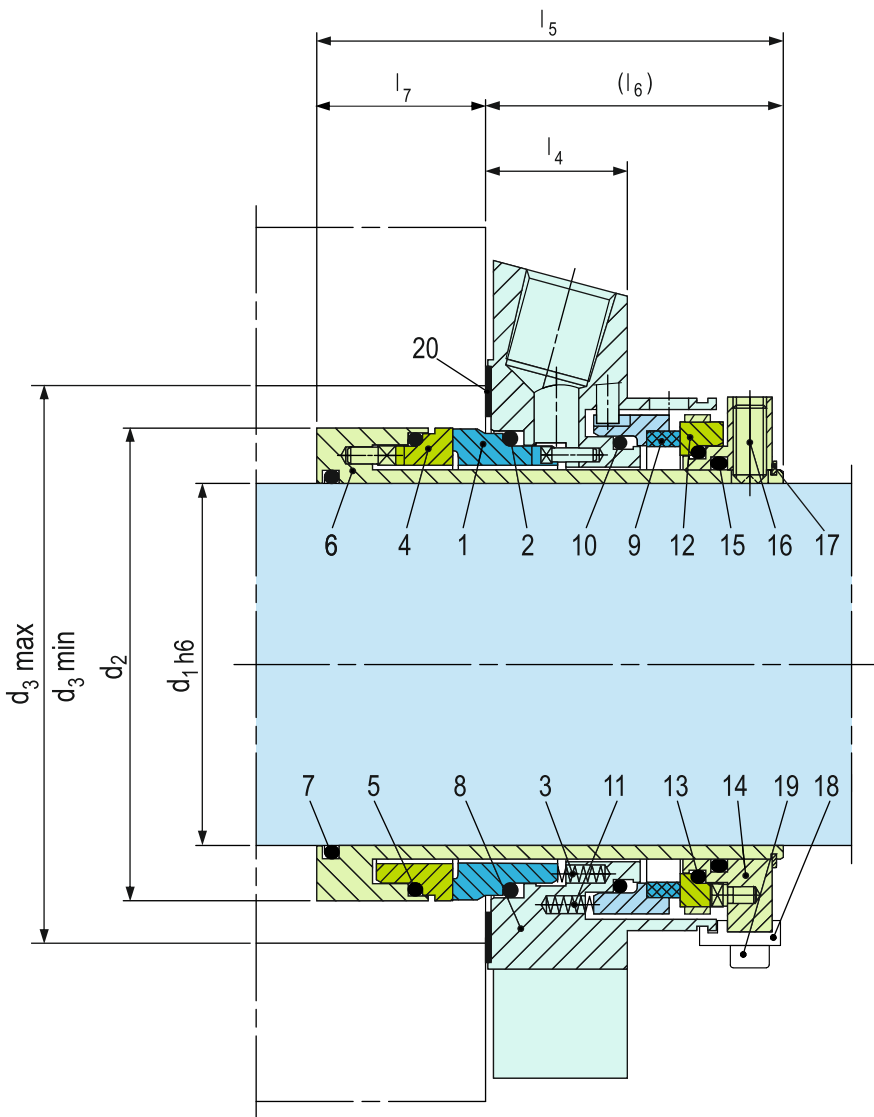

Note: The item numbers as depicted above are based on our technical experience and knowledge and are placed in the chronological order of their assembly procedure.

Item	Description
1	Seal face
2, 5, 7, 10, 13, 15	O-ring
3	Spring
4	Seat
6	Shaft sleeve
8	Cover
9	Seal face
11	Spring
12	Seat
14	Drive collar
16	Set screw
17	Snap ring
18	Assembly fixture
19	HSH Cap Screw
20	Gasket
21	Screw plug
22	Gasket

### Performance Capabilities

Sizes:  $d_1 = 1.000'' \dots 3.750''$

Other sizes on request

Temperature:  $t = -40\text{ }^\circ\text{C} \dots +220\text{ }^\circ\text{C} (-40\text{ }^\circ\text{F} \dots +428\text{ }^\circ\text{F})$

(Check O-ring resistance)

#### Sliding face material combination BQ1

Pressure:  $p_1 = 25\text{ bar (363 PSI)}$

Speed = 16 m/s (52 ft/s)

#### Sliding face material combination Q1Q1 or U2Q1

Pressure:  $p_1 = 20\text{ bar (290 PSI)}$

Speed = 10 m/s (33 ft/s)

Barrier fluid circulation system:

$p_{3\text{max}} = 25\text{ bar (363 PSI)}$

$\Delta p (p_3 - p_1)$  ideal = 2 ... 3 bar (29 ... 44 PSI),

7 bar (102 PSI) for barrier media with poor lubricating properties)

Pump startup:

$\Delta p (p_3 - p_1)_{\text{max}} = 25\text{ bar (363 PSI)}$  allowed

Recommended supply medium: max. ISO VG 5

Permissible axial movement:  $\pm 0.039''$ ,  $d_1 \geq 2.953'' \pm 0.059''$

### Installation, Details, Options

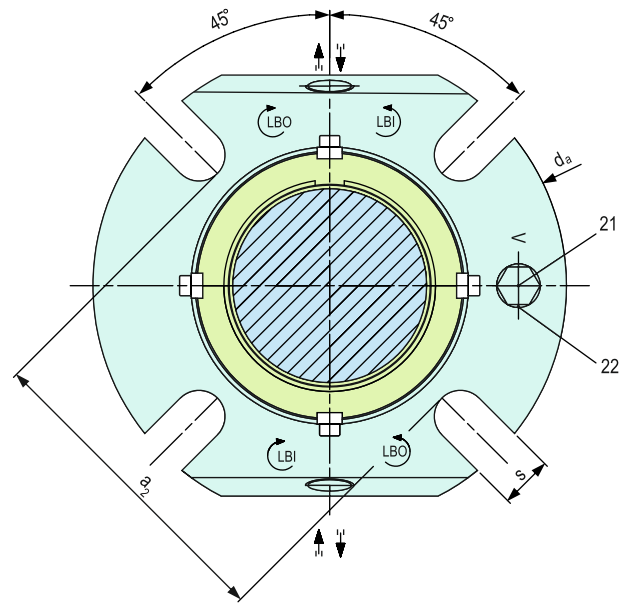

### Dimensional Data

#### BIG BORE - Dimensions in inch

$d_1$	$d_2$	$d_3\text{ min.}$	$d_3\text{ max.}$	$l_4$	$l_5$	$l_6$	$l_7$	$a_2$	$d_a$	$s$	Connection
1.000	-	-	-	-	-	-	-	-	-	-	-
1.125	1.713	1.752	2.795	1.000	3.228	1.886	1.343	3.311	4.500	0.437	1/4 NPT
1.250	-	-	-	-	-	-	-	-	-	-	-
1.375	1.960	2.000	3.189	1.000	3.406	2.083	1.323	3.543	5.118	0.437	1/4 NPT
1.500	-	-	-	-	-	-	-	-	-	-	-
1.625	-	-	-	-	-	-	-	-	-	-	-
1.750	2.461	2.500	4.055	1.000	3.406	2.083	1.323	4.567	6.496	0.559	3/8 NPT
1.875	2.583	2.661	3.937	1.000	3.406	2.083	1.323	4.409	5.984	0.551	3/8 NPT
2.000	2.677	2.756	4.567	1.260	3.406	2.102	1.303	4.882	6.260	0.551	3/8 NPT
2.125	2.834	2.913	4.528	1.000	3.406	2.102	1.303	5.276	6.890	0.709	3/8 NPT
2.250	2.960	3.093	4.409	1.276	3.406	2.102	1.303	4.685	6.417	0.709	3/8 NPT
2.500	3.212	3.299	5.276	1.250	3.406	2.102	1.303	5.512	7.795	0.709	3/8 NPT
2.625	3.338	3.170	5.118	1.250	3.406	2.102	1.303	5.354	6.890	0.709	3/8 NPT
2.750	3.660	3.740	5.236	1.276	3.406	2.102	1.303	5.512	7.480	0.630	3/8 NPT
3.000	3.937	4.016	5.512	1.276	3.406	2.516	1.303	5.906	8.228	0.650	3/8 NPT
3.250	-	-	-	-	-	-	-	-	-	-	-

#### STANDARD BORE - Dimensions in inch

$d_1$	$d_2$	$d_3\text{ min.}$	$d_3\text{ max.}$	$l_4$	$l_5$	$l_6$	$l_7$	$a_2$	$d_a$	$s$	Connection
1.000	1.693	1.732	2.205	1.000	3.406	2.102	1.303	2.441	3.937	0.433	1/4 NPT
1.125	1.713	1.752	2.205	1.000	3.228	3.228	1.343	2.441	4.134	0.437	1/4 NPT
1.250	1.969	2.008	2.402	1.000	3.406	2.102	1.303	2.756	4.252	0.433	1/4 NPT
1.375	1.961	2.000	2.402	1.000	3.406	2.102	1.303	2.756	4.213	0.437	1/4 NPT
1.500	2.200	2.244	2.717	1.000	3.406	2.102	1.303	2.953	4.488	0.551	3/8 NPT
1.625	2.340	2.421	2.795	1.000	3.406	2.102	1.303	3.091	4.921	0.551	3/8 NPT
1.750	2.461	2.500	2.953	1.000	3.406	2.102	1.303	3.228	5.118	0.559	3/8 NPT
1.875	2.583	2.661	3.070	1.000	3.406	2.102	1.303	3.307	5.118	0.551	3/8 NPT
2.000	2.677	2.756	3.189	1.000	3.406	2.102	1.303	3.425	5.472	0.630	3/8 NPT
2.125	2.834	2.913	3.583	1.000	3.406	2.102	1.303	3.819	5.512	0.650	3/8 NPT
2.250	2.960	3.039	3.583	1.000	3.406	2.102	1.303	3.858	5.866	0.650	3/8 NPT
2.375	3.070	3.125	3.590	1.000	-	-	-	-	6.181	0.709	3/8 NPT
2.500	3.212	3.291	3.937	1.122	3.406	2.102	1.303	4.528	6.693	0.709	3/8 NPT
2.625	3.338	3.417	4.016	1.250	3.406	2.102	1.303	4.528	6.378	0.630	3/8 NPT
2.750	3.660	3.740	4.370	1.260	3.406	2.102	1.303	4.646	7.441	0.709	3/8 NPT
3.000	3.937	4.016	4.724	1.260	4.252	2.516	1.736	5.000	7.835	0.709	3/8 NPT
3.250	4.189	4.268	4.921	1.260	4.252	2.516	1.736	5.315	7.830	0.709	3/8 NPT
3.750	4.689	4.750	5.433	1.000	-	-	-	-	8.189	0.866	3/8 NPT

**Note: Additional technical & dimensional information will be provided on request.**

The specifications, drawings, images etc included in this catalogue are intended to be generic and must be interpreted as equivalent or functionally equivalent, more specifically the performance capabilities mentioned in this catalogue is based on optimum values, however the performance of the product is dependent on size, material of construction, media, pressure, temperature, sliding velocity etc and it shall vary from size to size or application to application. Customers are requested to consult with Sealmatic before employing the product from this catalogue for any application.

# CTX Dual Seals

# Standard Cartridge Seals



### Product Description

1. Dual seal configuration
2. Balanced design
3. Independent of direction of rotation
4. Cartridge construction
5. Double pressure balanced
6. Designed with integrated pumping device for increased efficiency in circulation
7. Special design available for eccentric screw pumps

### Technical Features

1. Ideal for use in process pump standardization
2. O-ring is dynamically loaded to prevent shaft damage.
3. Dimensional modification of the stuffing box chamber is not required due to short radial installation height
4. Ideal to convert and retrofit pumps with packings and large volume OEM production
5. Cartridge unit factory assembled for easy installation, which reduces down-time
6. Rugged design for long operating life

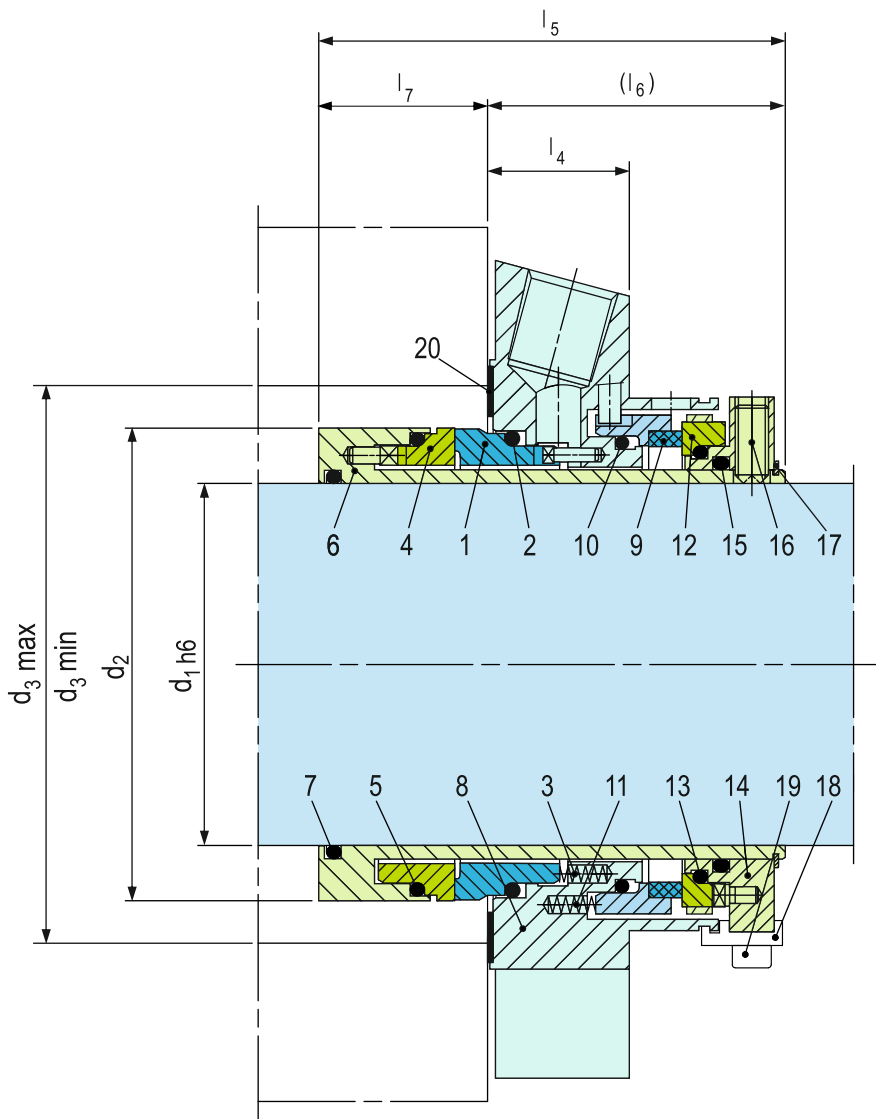

Note: The item numbers as depicted above are based on our technical experience and knowledge and are placed in the chronological order of their assembly procedure.

Item	Description
1	Seal face
2, 5, 7, 10, 13, 15	O-ring
3	Spring
4	Seat
6	Shaft sleeve
8	Cover
9	Seal face
11	Spring
12	Seat
14	Drive collar
16	Set screw
17	Snap ring
18	Assembly fixture
19	HSH Cap Screw
20	Gasket
21	Screw plug
22	Gasket

### Typical Industrial Applications

Chemical industry  
 Food and beverage industry  
 Petrochemical industry  
 Pharmaceutical industry  
 Universally applicable  
 Water and waste water technology  
 Centrifugal pumps  
 Eccentric screw pumps

### Materials

Seal face: Silicon carbide (Q1), Carbon graphite resin impregnated (B), Tungsten carbide (U2)  
 Seat: Silicon carbide (Q1)  
 Secondary seals: FKM (V), EPDM (E), FFKM (K), Perfluorocarbon rubber/PTFE (U1)  
 Springs: Hastelloy® C-4 (M)  
 Metal parts: CrNiMo steel (G), CrNiMo cast steel (G)

### Performance Capabilities

Sizes:  $d_1 =$  Upto 100 mm (Upto 4.000")  
 Other sizes on request  
 Temperature:  $t = -40\text{ }^\circ\text{C} \dots +220\text{ }^\circ\text{C}$   
 ( $-40\text{ }^\circ\text{F} \dots +428\text{ }^\circ\text{F}$ )  
 (Check O-ring resistance)

#### Sliding face material combination BQ1

Pressure:  $p_1 = 25\text{ bar}$  (363 PSI)  
 Speed = 16 m/s (52 ft/s)

#### Sliding face material combination Q1Q1 or U2Q1

Pressure:  $p_1 = 20\text{ bar}$  (290 PSI)  
 Speed = 10 m/s (33 ft/s)  
 Barrier fluid circulation system:  
 $p_{3\text{max}} = 25\text{ bar}$  (363 PSI)  
 $\Delta p (p_3 - p_1)$  ideal = 2 ... 3 bar (29 ... 44 PSI),  
 7 bar (102 PSI) for barrier media with poor lubricating properties)  
 Pump startup:  
 $\Delta p (p_3 - p_1)_{\text{max}} = 25\text{ bar}$  (363 PSI) allowed  
 Recommended supply medium: max. ISO VG 5  
 Permissible axial movement:  $\pm 1.0\text{ mm}$ ,  
 $d_1 \geq 75\text{ mm} \pm 1.5\text{ mm}$

### Installation, Details, Options

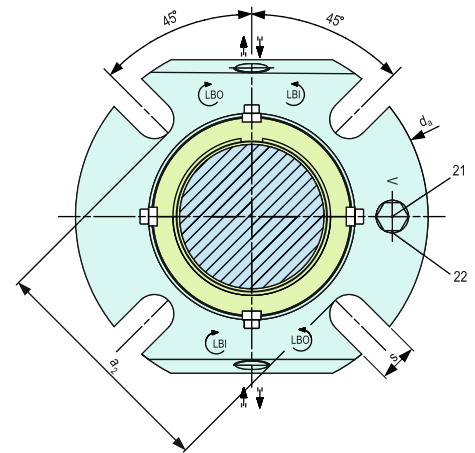

### Dimensional Data

#### Dimensions in inch

$d_1$	$d_2$	$d_3\text{ min.}$	$d_3\text{ max.}$	$l_4$	$l_5$	$l_6$	$l_7$	$a_2$	$d_a$	$s$	Connection
1.000	1.693	1.732	2.008	1.000	3.406	2.102	1.303	2.440	4.134	0.520	1/4 NPT
1.125	1.811	1.875	2.050	1.000	3.406	2.102	1.303	2.402	4.134	0.520	1/4 NPT
1.250	1.961	2.008	2.244	1.000	3.406	2.102	1.303	2.760	4.330	0.520	1/4 NPT
1.375	2.087	2.216	2.421	1.000	3.406	2.102	1.303	2.840	4.449	0.520	1/4 NPT
1.500	2.205	2.244	2.598	1.000	3.406	2.102	1.303	2.950	4.843	0.520	3/8 NPT
1.625	2.343	2.375	2.700	1.000	3.406	2.102	1.303	3.090	4.842	0.559	3/8 NPT
1.750	2.461	2.520	2.874	1.000	3.406	2.102	1.303	3.230	5.433	0.559	3/8 NPT
1.875	2.582	2.638	2.953	1.000	3.406	2.102	1.303	3.350	5.433	0.559	3/8 NPT
2.000	2.677	2.717	3.071	1.000	3.406	2.102	1.303	3.425	5.827	0.559	3/8 NPT
2.125	2.835	2.874	3.425	1.000	3.406	2.102	1.303	3.819	5.827	0.709	3/8 NPT
2.250	2.961	3.000	3.560	1.000	3.406	2.102	1.303	3.940	6.181	0.709	3/8 NPT
2.375	3.071	3.125	3.583	1.000	3.406	2.102	1.303	4.020	6.181	0.709	3/8 NPT
2.500	3.213	3.300	3.800	1.000	3.406	2.102	1.303	4.180	6.417	0.709	3/8 NPT
2.625	3.339	3.374	3.937	1.000	3.406	2.102	1.303	4.303	6.417	0.709	3/8 NPT
2.750	3.661	3.740	4.252	1.000	3.406	2.102	1.303	4.660	7.008	0.709	3/8 NPT
2.875	3.937	4.000	4.646	1.000	4.252	2.516	1.736	5.079	7.480	0.709	3/8 NPT
3.000	3.937	4.000	4.646	1.102	4.252	2.516	1.736	5.079	7.480	0.709	3/8 NPT
3.125	4.189	4.252	4.882	1.102	4.252	2.516	1.736	5.315	7.677	0.709	3/8 NPT
3.250	4.189	4.252	4.882	1.102	4.252	2.516	1.736	5.315	7.677	0.709	3/8 NPT
3.375	4.311	4.375	5.039	1.102	4.252	2.516	1.736	5.472	7.795	0.866	3/8 NPT
3.500	4.437	4.500	5.517	1.102	4.252	2.516	1.736	5.591	7.795	0.866	3/8 NPT
3.625	4.563	4.625	5.315	1.102	4.252	2.516	1.736	5.709	8.071	0.866	3/8 NPT
3.750	4.689	4.752	5.433	1.102	4.252	2.516	1.736	5.827	8.189	0.866	3/8 NPT
4.000	4.937	5.000	5.669	1.102	4.252	2.516	1.736	6.063	8.583	0.866	3/8 NPT

#### Dimensions in millimeter

$d_1$	$d_2$	$d_3\text{ min.}$	$d_3\text{ max.}$	$l_4$	$l_5$	$l_6$	$l_7$	$a_2$	$d_a$	$s$	Connection
25	43.0	44.0	51.5	25.4	86.5	53.4	33.1	62	105	13.2	1/4 NPT
28	46.0	47.0	52.0	25.4	86.5	53.4	33.1	61	105	13.2	1/4 NPT
30	48.0	49.0	56.0	25.4	86.5	53.4	33.1	67	105	13.2	1/4 NPT
32	49.8	51.0	57.0	25.4	86.5	53.4	33.1	70	108	13.2	1/4 NPT
33	49.8	51.0	57.0	25.4	86.5	53.4	33.1	70	108	13.2	1/4 NPT
35	53.0	54.0	61.5	25.4	86.5	53.4	33.1	72	113	13.2	1/4 NPT
38	56.0	57.0	66.0	25.4	86.5	53.4	33.1	75	123	13.2	3/8 NPT
40	58.0	59.0	68.0	25.4	86.5	53.4	33.1	77	123	14.2	3/8 NPT
42	61.0	62.0	69.5	25.4	86.5	53.4	33.1	80	133	14.2	3/8 NPT
43	61.0	62.0	70.5	25.4	86.5	53.4	33.1	80	133	14.2	3/8 NPT
45	62.5	64.0	73.0	25.4	86.5	53.4	33.1	82	138	14.2	3/8 NPT
48	65.6	67.0	75.0	25.4	86.5	53.4	33.1	85	138	16.0	3/8 NPT
50	68.0	69.0	78.0	25.4	86.5	53.4	33.1	87	148	16.0	3/8 NPT
53	72.0	73.0	87.0	25.4	86.5	53.4	33.1	97	148	18.0	3/8 NPT
55	73.0	75.0	83.0	25.4	86.5	53.4	33.1	92	148	18.0	3/8 NPT
60	78.0	79.0	91.0	25.4	86.5	53.4	33.1	102	157	18.0	3/8 NPT
65	84.8	85.7	98.5	25.4	86.5	53.4	33.1	109	163	18.0	3/8 NPT
70	93.0	95.0	108.0	25.4	86.5	53.4	33.1	118	178	18.0	3/8 NPT
75	100.0	101.6	118.0	28.0	108.0	63.9	44.1	129	190	18.0	3/8 NPT
80	106.4	108.0	124.0	28.0	108.0	63.9	44.1	135	195	18.0	3/8 NPT
85	109.5	111.1	128.0	28.0	108.0	63.9	44.1	139	198	22.0	3/8 NPT
90	115.9	117.5	135.0	28.0	108.0	63.9	44.1	145	205	22.0	3/8 NPT
95	119.1	120.7	138.0	28.0	108.0	63.9	44.1	148	208	22.0	3/8 NPT
100	125.4	127.0	144.0	28.0	108.0	63.9	44.1	154	218	22.0	3/8 NPT

Note: Additional technical & dimensional information will be provided on request.

The specifications, drawings, images etc included in this catalogue are intended to be generic and must be interpreted as equivalent or functionally equivalent, more specifically the performance capabilities mentioned in this catalogue is based on optimum values, however the performance of the product is dependent on size, material of construction, media, pressure, temperature, sliding velocity etc and it shall vary from size to size or application to application. Customers are requested to consult with Sealmatic before employing the product from this catalogue for any application.

# ETX Single Seals

# Standard Cartridge Seals



### Product Description

1. Single seal configuration
2. Balanced design
3. Independent of direction of rotation
4. Cartridge construction
5. Available with flush and quench connections

### Technical Features

1. Ideal for use in process pump standardization
2. O-ring is dynamically loaded to prevent shaft damage.
3. Dimensional modification of the stuffing box chamber is not required due to short radial installation height
4. Ideal to convert and retrofit pumps with packings and large volume OEM production
5. Cartridge unit factory assembled for easy installation, which reduces downtime
6. Rugged design for long operating life

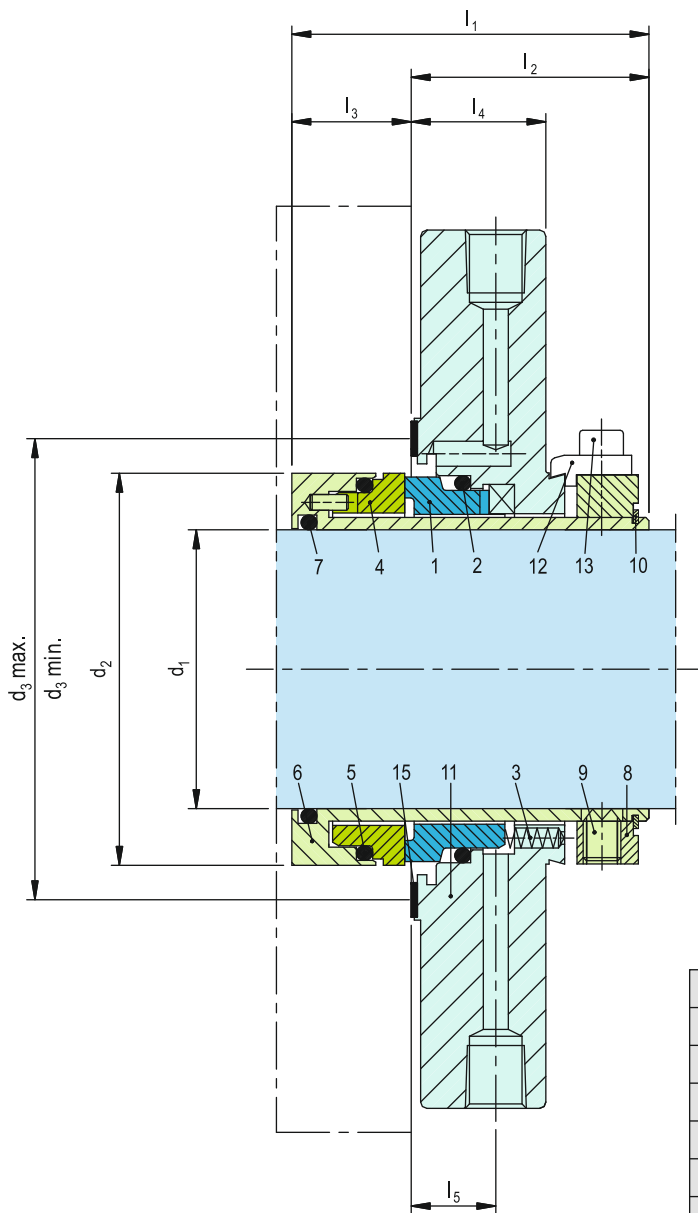

**Note:** The item numbers as depicted above are based on our technical experience and knowledge and are placed in the chronological order of their assembly procedure.

### Typical Industrial Applications

- Chemical industry
- Food and beverage industry
- Petrochemical industry
- Pharmaceutical industry
- Process Pumps
- Water and waste water technology

### Materials

Seal face: Silicon carbide (Q1), Carbon graphite resin impregnated (B), Tungsten carbide (U2)  
 Seat: Silicon carbide (Q1)  
 Secondary seals: FKM (V), EPDM (E), FFKM (K), Perfluorocarbon rubber/PTFE (U1)  
 Springs: Hastelloy® C-4 (M)  
 Metal parts: CrNiMo steel (G), CrNiMo cast steel (G)

### Performance Capabilities

ETX-SN  
 Sizes: Upto 70 mm (2.75")  
 Other sizes on request  
 Temperature:  $t = -40\text{ }^{\circ}\text{C} \dots +220\text{ }^{\circ}\text{C}$   
 ( $-40\text{ }^{\circ}\text{F} \dots +428\text{ }^{\circ}\text{F}$ )  
 (Check O-ring resistance)  
**Sliding face material combination BQ1**  
 Pressure:  $p_1 = 20\text{ bar (290 PSI)}$   
 Speed = 11.2 m/s  
 Permissible axial movement:  $\pm 1.0\text{ mm}$

Item	Description
1	Seal face
2, 5, 7	O-ring
3	Spring
4	Seat
6	Shaft sleeve
8	Drive collar
9	Set screw

Item	Description
10	Snap ring
11	Cover
12	Assembly fixture (remove after installation)
13	HSH Cap Screw
14	Plug
15	Gasket

## Installation, Details, Options

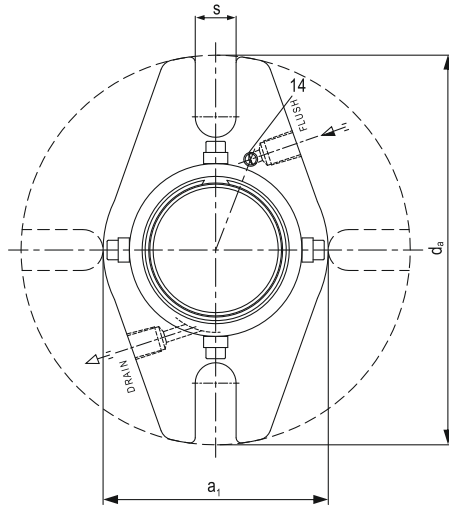

## Dimensional Data

### Dimensions in inches

d <sub>1</sub>	d <sub>2</sub>	d <sub>3</sub> min.	d <sub>3</sub> max.	l <sub>1</sub>	l <sub>2</sub>	l <sub>3</sub>	l <sub>4</sub>	l <sub>5</sub>	a <sub>1</sub>	d <sub>a</sub>	s	Connection
1.000	1.851	1.929	2.402	2.244	1.496	0.748	0.846	0.531	2.480	4.134	0.511	1/8" NPT
1.125	1.930	2.047	2.480	2.244	1.496	0.748	0.846	0.531	2.480	4.134	0.511	1/8" NPT
1.250	2.048	2.126	2.559	2.244	1.496	0.748	0.846	0.531	2.678	4.134	0.511	1/8" NPT
1.375	2.126	2.244	2.677	2.244	1.496	0.748	0.846	0.531	2.796	4.567	0.511	1/8" NPT
1.500	2.245	2.441	2.874	2.244	1.496	0.748	0.846	0.531	2.993	4.961	0.590	1/8" NPT
1.625	2.402	2.598	3.031	2.244	1.496	0.748	0.846	0.531	3.150	5.276	0.590	1/8" NPT
1.750	2.520	2.677	3.110	2.244	1.496	0.748	0.846	0.531	3.229	5.552	0.590	1/8" NPT
1.875	2.638	2.795	3.228	2.244	1.496	0.748	0.846	0.531	3.347	5.552	0.590	1/8" NPT
2.000	2.835	3.031	3.465	2.244	1.496	0.748	0.846	0.531	3.662	5.945	0.709	1/8" NPT
2.125	2.914	3.110	3.543	2.244	1.496	0.748	0.846	0.531	3.662	5.945	0.709	1/8" NPT
2.250	3.032	3.228	3.661	2.244	1.496	0.748	0.846	0.531	3.780	6.142	0.709	1/8" NPT
2.375	3.111	3.425	3.858	2.244	1.496	0.748	0.846	0.531	3.977	6.339	0.709	1/8" NPT
2.500	3.229	3.543	3.976	2.244	1.496	0.748	0.846	0.531	4.095	6.536	0.709	1/8" NPT
2.625	3.426	3.819	4.252	2.244	1.496	0.748	0.846	0.531	4.370	6.733	0.709	1/8" NPT
2.750	3.504	4.213	4.646	2.244	1.496	0.748	0.846	0.531	4.764	7.126	0.709	1/8" NPT

### Dimensions in millimeter

d <sub>1</sub>	d <sub>2</sub>	d <sub>3</sub> min.	d <sub>3</sub> max.	l <sub>1</sub>	l <sub>2</sub>	l <sub>3</sub>	l <sub>4</sub>	l <sub>5</sub>	a <sub>1</sub>	d <sub>a</sub>	s	Connection
25	44	49	60	57	38	19	21.5	13.5	63	105	13	1/8" NPT
28	47	50	60	57	38	19	21.5	13.5	64	105	13	1/8" NPT
30	49	52	63	57	38	19	21.5	13.5	66	105	13	1/8" NPT
33	52	54	65	57	38	19	21.5	13.5	68	105	13	1/8" NPT
35	54	57	68	57	38	19	21.5	13.5	71	116	13	1/8" NPT
38	57	62	73	57	38	19	21.5	13.5	76	126	15	1/8" NPT
40	59	62	73	57	38	19	21.5	13.5	76	126	15	1/8" NPT
42	61	66	77	57	38	19	21.5	13.5	80	134	15	1/8" NPT
43	62	67	78	57	38	19	21.5	13.5	81	134	15	1/8" NPT
45	64	68	79	57	38	19	21.5	13.5	82	141	15	1/8" NPT
48	67	71	82	57	38	19	21.5	13.5	85	141	15	1/8" NPT
50	69	74	85	57	38	19	21.5	13.5	88	141	15	1/8" NPT
52	72	77	88	57	38	19	21.5	13.5	91	151	18	1/8" NPT
53	72	77	88	57	38	19	21.5	13.5	91	151	18	1/8" NPT
55	74	79	90	57	38	19	21.5	13.5	93	151	18	1/8" NPT
58	77	82	93	57	38	19	21.5	13.5	96	156	18	1/8" NPT
60	79	87	98	57	38	19	21.5	13.5	101	161	18	1/8" NPT
63	82	90	101	57	38	19	21.5	13.5	104	166	18	1/8" NPT
65	84	92	103	57	38	19	21.5	13.5	106	166	18	1/8" NPT
68	87	97	108	57	38	19	21.5	13.5	111	171	18	1/8" NPT
70	89	107	118	57	38	19	21.5	13.5	121	181	18	1/8" NPT

**Note: Additional technical & dimensional information will be provided on request**

The specifications, drawings, images etc included in this catalogue are intended to be generic and must be interpreted as equivalent or functionally equivalent, more specifically the performance capabilities mentioned in this catalogue is based on optimum values, however the performance of the product is dependent on size, material of construction, media, pressure, temperature, sliding velocity etc and it shall vary from size to size or application to application. Customers are requested to consult with Sealmatic before employing the product from this catalogue for any application.

# UTX Single Seals

# Standard Cartridge Seals



### Product Description

1. Single seal configuration
2. Unbalanced design
3. Independent of direction of rotation
4. Cartridge construction

### Technical Features

1. Ideal for use in process pump standardization
2. Flushing connection according to API 682, Plan 11 for seal chamber cleaning and cooling
3. Low cost cartridge solution
4. Dimensional modification of the stuffing box chamber is not required due to short radial installation height
5. Ideal to convert and retrofit pumps with packings and large volume OEM production
6. Cartridge unit factory assembled for easy installation, which reduces downtime
7. Rugged design for long operating life

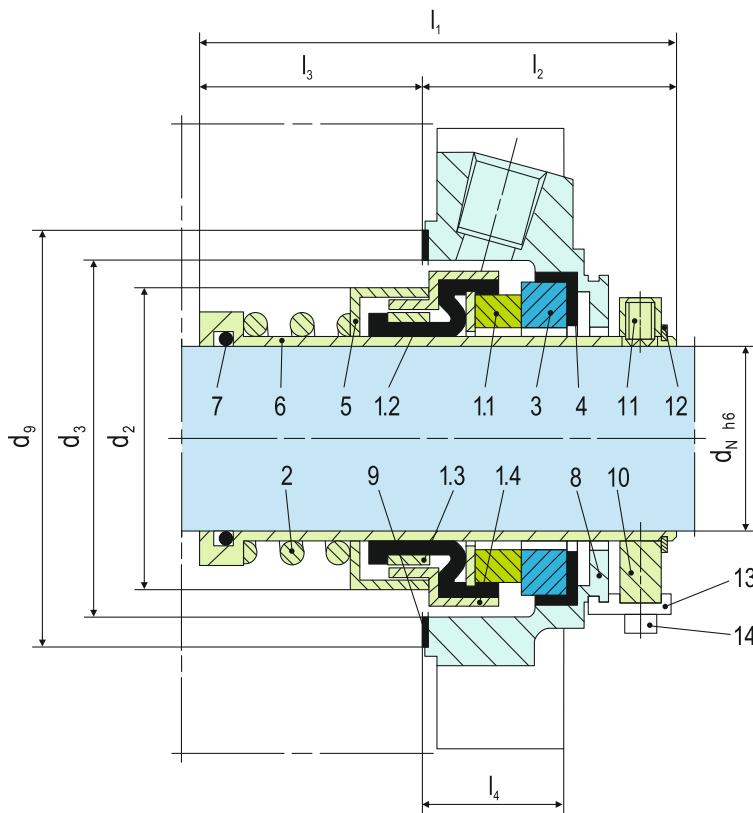

Note: The item numbers as depicted above are based on our technical experience and knowledge and are placed in the chronological order of their assembly procedure.

Item	Description
1	Bellows unit
1.1	Seal face
1.2	Bellows
1.3	Drive collar
1.4	L-ring (spring collar)
2	Spring
3	Seat
4	O-ring or L-ring
5	Spacer ring

Item	Description
6	Shaft sleeve
7	O-ring
8	Cover
9	Gasket
10	Drive collar
11	Set screw
12	Snap ring
13	Assembly fixture
14	HSH Cap Screw

### Typical Industrial Applications

Water and waste water technology  
 Sewage water  
 Cold and hot water  
 Cooling fluids  
 Beverages  
 Circulating pumps  
 Water and waste water pumps

### Materials

Seal face: Carbon graphite resin impregnated (B), Silicon carbide (Q1)  
 Seat: Silicon carbide (Q1)  
 Secondary seals: FKM (V), EPDM (E)  
 Metal parts: CrNiMo steel (G), CrNiMo cast steel (G)

### Performance Capabilities

Sizes: Upto 75 mm (1" ... 2.625")  
 Pressure:  $p_1 = 12 \text{ bar (174 PSI)}$   
 Temperature:  $t = -20 \text{ }^\circ\text{C} \dots +140 \text{ }^\circ\text{C}$   
 (-4 °F...+284 °F)  
 Speed = 10 m/s (33 ft/s)  
 Axial movement:  $\pm 0.5 \text{ mm}$

### Stationary Seats

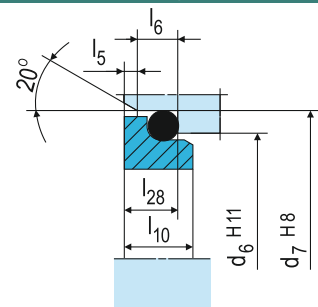

G6 (EN 12756)



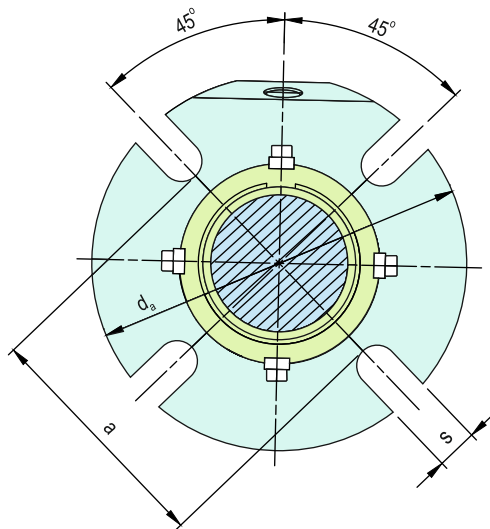

### Dimensional Data

#### Dimensions in inch

$d_N$	$d_2$	$d_3$ min	$d_3$ max	$d_9$	$d_a$	$a$	$s$	$l_1$	$l_2$	$l_3$	$l_4$	Connection
1.000	1.512	1.634	2.000	2.362	4.134	2.440	0.520	2.579	1.614	0.965	0.906	1/4 NPT
1.125	1.669	1.750	2.050	2.362	4.134	2.441	0.520	2.677	1.634	1.043	0.906	1/4 NPT
1.250	1.772	1.890	2.250	2.559	4.331	2.638	0.520	2.736	1.654	1.083	0.906	1/4 NPT
1.375	1.933	2.000	2.420	2.677	4.213	2.756	0.520	2.854	1.732	1.122	1.024	1/4 NPT
1.500	2.020	2.146	2.625	2.874	4.843	2.950	0.579	2.854	1.732	1.122	1.024	1/4 NPT
1.750	2.354	2.480	2.812	3.110	5.118	3.230	0.559	3.012	1.752	1.260	1.024	1/4 NPT
1.875	2.433	2.559	2.940	3.228	5.118	3.307	0.559	3.071	1.772	1.299	1.024	1/4 NPT
2.000	2.551	2.677	3.190	3.346	5.827	3.430	0.579	3.169	1.850	1.319	1.102	3/8 NPT
2.125	2.795	2.875	3.437	3.740	5.512	3.820	0.689	3.287	1.850	1.437	1.102	3/8 NPT
2.250	2.874	2.992	3.560	3.780	6.181	3.858	0.689	3.287	1.850	1.437	1.102	3/8 NPT
2.375	3.012	3.110	3.590	3.937	6.181	4.020	0.689	3.366	1.850	1.516	1.102	3/8 NPT
2.500	3.209	3.287	3.800	4.173	6.693	4.252	0.689	3.465	1.909	1.555	1.102	3/8 NPT
2.625	3.268	3.374	3.937	4.252	6.378	4.331	0.689	3.465	1.909	1.555	1.102	3/8 NPT

#### Dimensions in millimeter

$d_N$	$d_2$	$d_3$ min	$d_3$ max	$d_6$	$d_7$	$d_9$	$d_a$	$a$	$s$	$l_1$	$l_2$	$l_3$	$l_4$	$l_5$	$l_6$	$l_{10}$	$l_{28}$	Connection
25	38.4	41.5	51.0	34.0	40	60	105	62	13.2	65.5	41.0	24.5	23	2	5	8.5	7.5	1/4 NPT
28	42.4	44.5	52.0	37.0	43	60	105	62	13.2	68.0	41.5	26.5	23	2	5	8.5	7.5	1/4 NPT
30	42.4	45.5	56.0	39.0	45	63	105	67	13.2	68.0	41.5	26.5	23	2	5	8.5	7.5	1/4 NPT
32	45.0	48.0	57.2	42.0	48	65	110	67	13.2	69.5	42.0	27.5	23	2	5	8.5	7.5	1/4 NPT
33	45.0	48.0	57.0	42.0	48	65	110	67	13.2	69.5	42.0	27.5	23	2	5	8.5	7.5	1/4 NPT
35	49.0	50.8	61.5	44.0	50	68	107	70	13.2	72.5	44.0	28.5	26	2	5	8.5	7.5	1/4 NPT
38	51.3	54.5	66.0	49.0	56	73	123	75	14.7	72.5	44.0	28.5	26	2	6	10	9	1/4 NPT
40	54.3	57.5	68.0	51.0	58	75	123	77	14.7	75.5	44.5	31.0	26	2	6	10	9	1/4 NPT
43	56.3	59.5	70.5	54.0	61	78	133	80	14.7	76.5	44.5	32.0	26	2	6	10	9	1/4 NPT
45	61.0	63.0	73.0	56.0	63	79	130	82	14.2	76.5	44.5	32.0	26	2	6	10	9	1/4 NPT
48	61.8	65.0	75.0	59.0	66	82	130	84	14.2	78.0	45.0	33.0	26	2	6	10	9	1/4 NPT
50	64.8	68.0	78.0	62.0	70	85	148	87	14.7	80.5	47.0	33.5	28	2.5	6	10.5	9.5	3/8 NPT
53	71.0	73.0	87.0	65.0	73	95	148	97	17.5	81.5	47.0	34.5	28	2.5	6	12	11	3/8 NPT
55	71.0	73.0	83.0	67.0	75	90	148	92	17.5	83.5	47.0	36.5	28	2.5	6	12	11	3/8 NPT
60	76.5	79.0	91.0	72.0	80	100	157	102	17.5	85.5	47.0	38.5	28	2.5	6	12	11	3/8 NPT
65	83.0	85.7	98.5	77.0	85	108	162	110	17.5	88.0	48.5	39.5	28	2.5	6	12	11	3/8 NPT
70	88.0	94.0	108.0	83.0	92	116	178	118	17.5	92.0	48.5	43.5	28	2.5	7	12.5	11.3	3/8 NPT
75	93.4	98.4	118.0	88.0	97	125	190	127	17.5	93.5	49.0	44.5	28	2.5	7	12.5	11.3	3/8 NPT
80	97.0	115.0	125.0	95.0	105	131	202	134	18.0	93.5	49.0	45.5	28	3	7	13	12	3/8 NPT

**Note: Additional technical & dimensional information will be provided on request**

The specifications, drawings, images etc included in this catalogue are intended to be generic and must be interpreted as equivalent or functionally equivalent, more specifically the performance capabilities mentioned in this catalogue is based on optimum values, however the performance of the product is dependent on size, material of construction, media, pressure, temperature, sliding velocity etc and it shall vary from size to size or application to application. Customers are requested to consult with Sealmatic before employing the product from this catalogue for any application.



### Product Description

1. Single seal configuration
2. Balanced design
3. Independent of direction of rotation
4. Cartridge construction
5. Metal bellows design
6. Single seal with quench and lip seal (-QN) or throttle ring (-TN)
7. Connections for flush and quench available
8. Multipoint injection ring design for (-QNM, -TNM)

### Technical Features

1. Ideal for use in process pump standardization
2. Dimensional modification of the stuffing box chamber is not required due to short radial installation height
3. Ideal to convert and retrofit pumps with packings and large volume OEM production
4. Cartridge unit factory assembled for easy installation, which reduces downtime
5. Rugged design for long operating life
6. Bellows design efficiently ensure self-cleaning
7. Suitable for high temperature applications

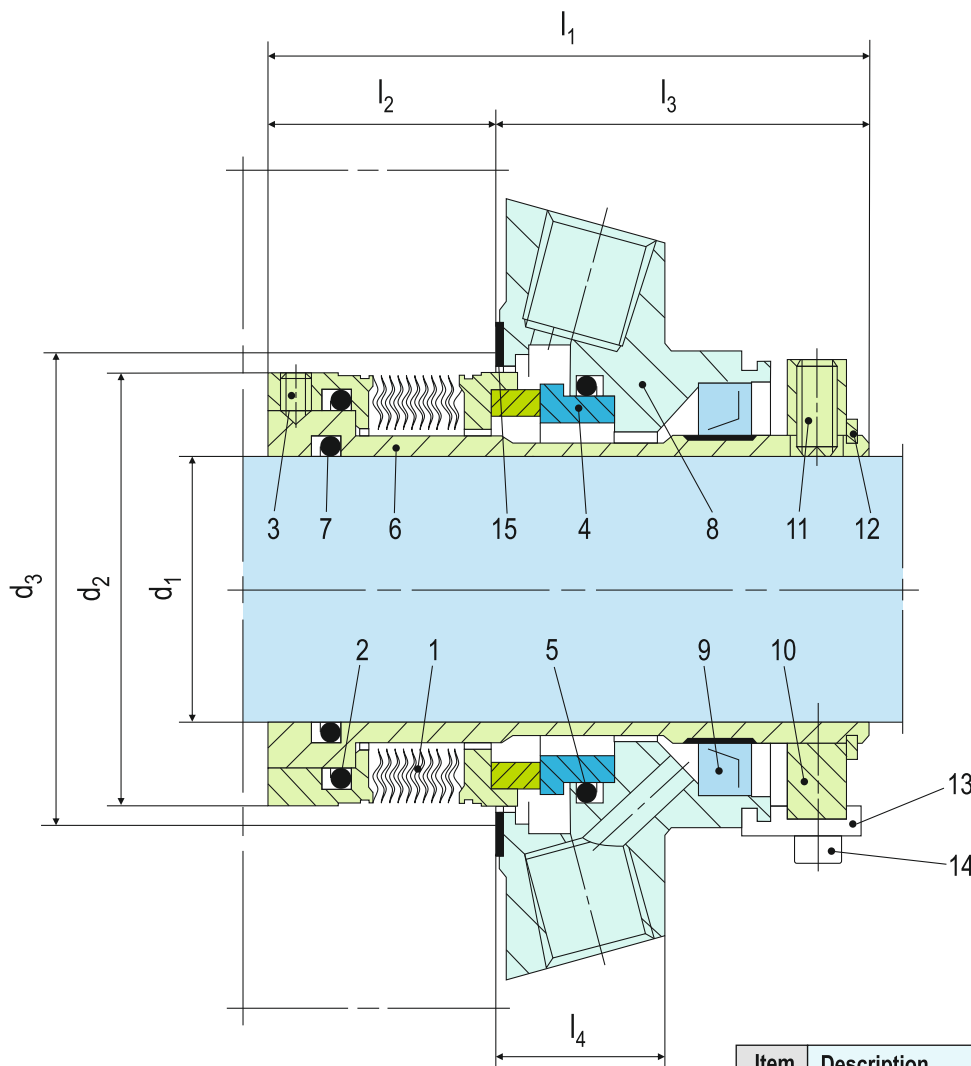

**Note:** The item numbers as depicted above are based on our technical experience and knowledge and are placed in the chronological order of their assembly procedure.

Item	Description
1	Bellows unit
2, 5, 7	O-ring
3, 11	Set screw
4	Seat
6	Shaft sleeve
8	Cover

Item	Description
9	Lip seal (-QN) or throttle ring (-TN)
10	Drive collar
12	Retaining ring
13	Assembly fixture
14	HSH Cap Screw
15	Gasket

### Typical Industrial Applications

- Refining technology
- Petrochemical industry
- Hot media
- Cold media
- Highly viscous media
- Pumps
- Special rotating equipment

### Materials

- Seal face: Carbon graphite antimony impregnated (A), Silicon carbide (Q1)
- Seat: Silicon carbide (Q1)
- Secondary seals: FKM (V), EPDM (E), FFKM (K)
- Bellows: Inconel® 718 (M6)
- Metal parts: CrNiMo steel (G), Duplex (G1)
- Throttle ring: PTFE carbon graphite reinforced (T12)
- Lip seal: NBR (P), PTFE carbon reinforced (T3)

### Performance Capabilities

- Shaft diameter:  $d_1 = 25 \dots 80 \text{ mm}$  (1" ... 3.15")
- Temperature:  $t^1 = -40 \text{ }^\circ\text{C} \dots +220 \text{ }^\circ\text{C}$  (-40 °F ... +428 °F)
- Pressure:  $p = 25 \text{ bar}$  (363 PSI)
- <sup>1</sup>Operating limits of O-rings to be observed

## Installation, Details, Options

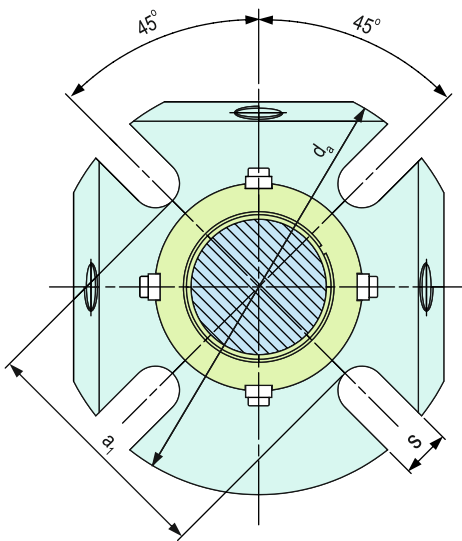

## Product Variants

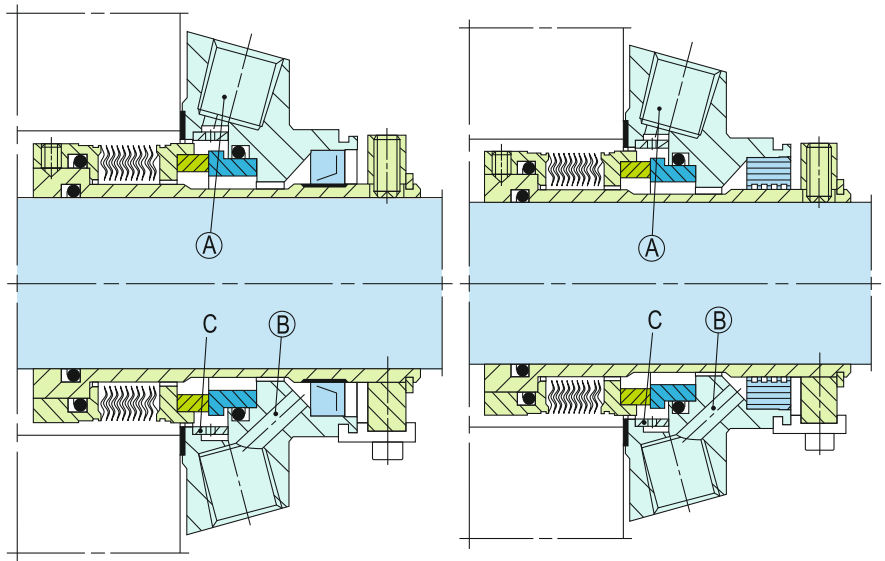

### MTX-QNM

Single seal, as MTX-QN with additional multipoint injection ring (item C).

### MTX-TNM

Single seal, as MTX-TN with additional multipoint injection ring (item C).

## Dimensional Data

Dimensions in millimeter

d <sub>1</sub>	d <sub>2</sub>	d <sub>3</sub> min.	d <sub>3</sub> max.	l <sub>1</sub>	l <sub>2</sub>	l <sub>3</sub>	l <sub>4</sub>	d <sub>a</sub>	a <sub>1</sub>	s	Connection
25	45.0	47.0	51.0	79.5	26.1	53.4	25.4	105.0	62.0	13.2	1/4 NPT
30	49.4	52.0	56.0	78.4	25.0	53.4	25.4	105.0	67.0	13.2	1/4 NPT
32	52.3	54.5	57.0	78.4	25.0	53.4	25.4	108.0	70.0	13.2	1/4 NPT
33	52.3	54.5	57.0	78.4	25.0	53.4	25.4	108.0	70.0	13.2	1/4 NPT
35	54.8	58.0	61.5	78.4	25.0	53.4	25.4	113.0	72.0	13.2	1/4 NPT
38	57.5	60.0	66.0	78.4	25.0	53.4	25.4	123.0	75.0	13.2	3/8 NPT
40	58.8	62.0	68.0	78.2	24.8	53.4	25.4	123.0	77.0	14.2	3/8 NPT
43	61.9	64.5	70.5	78.4	25.0	53.4	25.4	133.0	80.0	14.2	3/8 NPT
45	65.0	68.5	73.0	78.4	25.0	53.4	25.4	138.0	82.0	14.2	3/8 NPT
48	68.4	71.0	75.0	78.7	25.3	53.4	25.4	138.0	85.0	14.2	3/8 NPT
50	70.0	73.0	78.0	79.1	25.7	53.4	25.4	148.0	87.0	14.2	3/8 NPT
53	71.9	75.0	87.0	77.8	24.4	53.4	25.4	148.0	97.0	18.0	3/8 NPT
55	74.6	77.0	83.0	78.9	25.5	53.4	25.4	148.0	92.0	18.0	3/8 NPT
60	83.9	87.0	91.0	80.1	26.7	53.4	25.4	157.0	102.0	18.0	3/8 NPT
65	87.5	90.0	98.5	80.0	26.6	53.4	25.4	163.0	109.3	18.0	3/8 NPT
70	93.0	98.0	108.0	81.5	28.1	53.4	25.4	178.0	118.3	18.0	3/8 NPT
75	96.8	101.6	118.0	94.4	30.5	63.9	28.0	190.0	129.0	18.0	3/8 NPT
80	104.7	108.0	124.0	94.4	30.4	64.0	28.0	195.0	135.0	18.0	3/8 NPT

**Note:** Additional technical & dimensional information will be provided on request.

The specifications, drawings, images etc included in this catalogue are intended to be generic and must be interpreted as equivalent or functionally equivalent, more specifically the performance capabilities mentioned in this catalogue is based on optimum values, however the performance of the product is dependent on size, material of construction, media, pressure, temperature, sliding velocity etc and it shall vary from size to size or application to application. Customers are requested to consult with Sealmatic before employing the product from this catalogue for any application.



### Product Description

1. Dual seal configuration
2. Balanced design
3. Independent of direction of rotation
4. Cartridge construction
5. Metal bellows design
6. Designed with integrated pumping device for increased efficiency in circulation
7. Stationary O-ring design
8. Seals with API Plan 52 and API Plan 53/54

### Technical Features

1. Ideal for use in process pump standardization
2. O-ring is dynamically loaded to prevent shaft damage.
3. Dimensional modification of the stuffing box chamber is not required due to short radial installation height
4. Ideal to convert and retrofit pumps with packings and large volume OEM production
5. Cartridge unit factory assembled for easy installation, which reduces downtime
6. Rugged design for long operating life
7. Bellows design efficiently ensure self-cleaning
8. Suitable for high temperature applications

### Typical Industrial Applications

- Refining technology
- Petrochemical industry
- Hot media
- Cold media
- Highly viscous media
- Pumps
- Special rotating equipment

### Materials

- Seal face: Carbon graphite (A), Silicon carbide (Q1)
- Seat: Silicon carbide (Q1), Tungsten carbide (U2)
- Secondary seals: FPM (V), EPDM (E), FFKM (K)
- Bellows: Inconel® 718 (M6)
- Springs: Hastelloy® C-4 (M)
- Metal parts: CrNiMo steel (G), Duplex (G1)

### Performance Capabilities

- Shaft diameter:  $d_1 = 25 \dots 80 \text{ mm}$  (1" ... 3.15")
- Temperature :  $t^* = -40 \text{ °C} \dots +220 \text{ °C}$   
(-40 °F ... +428 °F)
- Pressure:  $p_1 = 25 \text{ bar}$  (232 PSI)
- Speed = 20 m/s (66 ft/s)
- Barrier fluid circulation system:  
 $p_{3\text{max}} = 16 \text{ bar}$  (232 PSI)  
 $\Delta p (p_3 - p_1) \text{ ideal} = 2 \dots 3 \text{ bar}$  (29 ... 44 PSI)  
 $\Delta p (p_3 - p_1) \text{ max.}$   
= 10 bar (145 PSI) at  $<120 \text{ °C}$  (<248 °F)  
= 5 bar (73 PSI) at  $\leq 220 \text{ °C}$  ( $\leq 232 \text{ °F}$ )  
API Plan 52 (53/54)  
Pump startup:  
 $\Delta p (p_3 - p_1) \text{ max. } 16 \text{ bar}$  (232 PSI) allowed  
\* Operating limits of O-rings to be observed

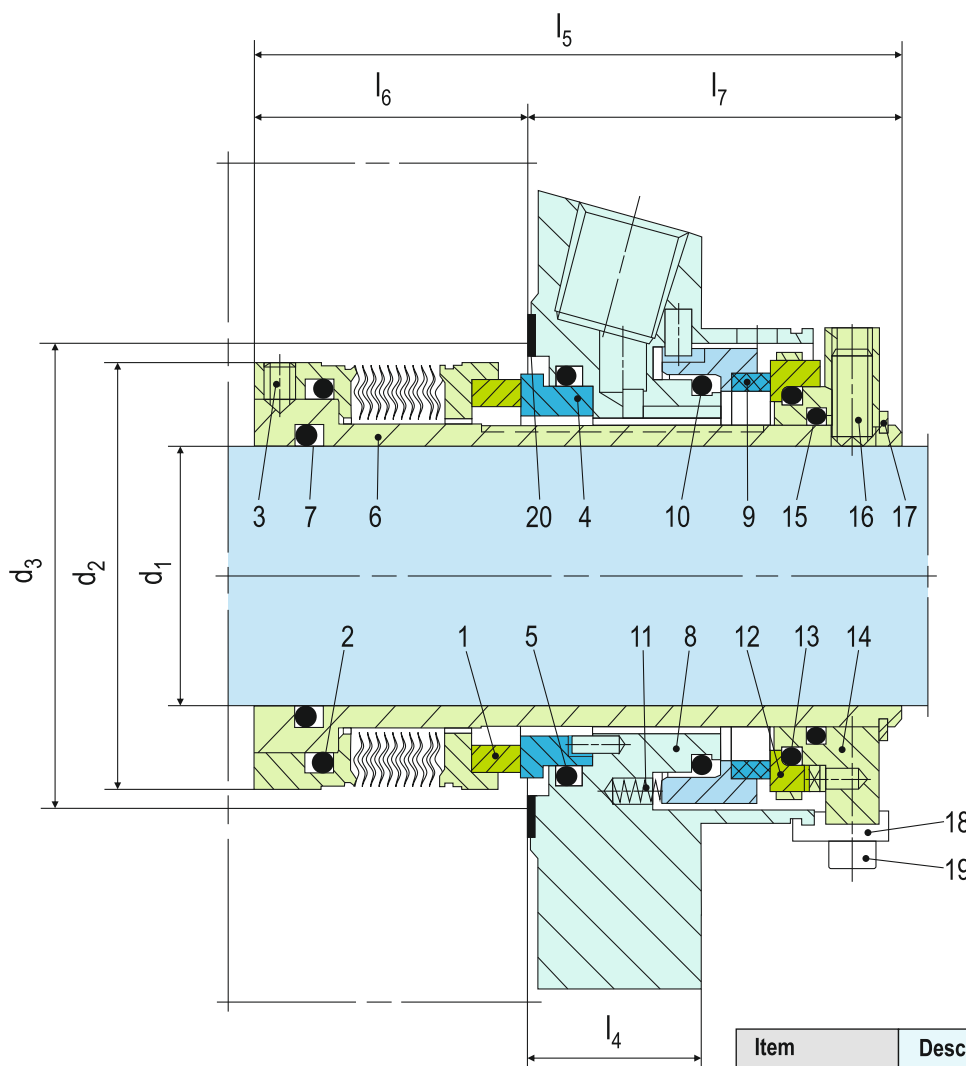

**Note:** The item numbers as depicted above are based on our technical experience and knowledge and are placed in the chronological order of their assembly procedure.

Item	Description
1	Bellows unit
2, 5, 7, 10, 13, 15	O-ring
3, 16	Set screw
4	Seat
6	Shaft sleeve
8	Cover
9	Seal face
11	Spring

Item	Description
12	Seat
14	Drive collar
17	Retaining ring
18	Assembly fixture
19	HSH Cap Screw
20	Gasket
21	Screw Plug
22	Gasket

## Installation, Details, Options

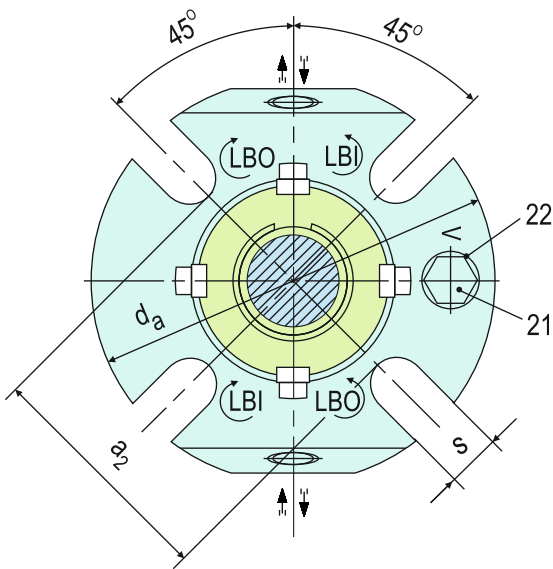

## Product Variants

### MTX9-DN

Dimensions, items and descriptions as for MTX-DN, but with optimized seal face geometry for pressurized operation according to API Plan 53/54. A barrier fluid system (e.g. Sealmatic BFS2000) is necessary.

Pressure:  $p_1 = 10$  bar (145 PSI)

Speed = 20 m/s (66 ft/s)

Barrier fluid circulation system:

$p_{3max} = 16$  bar (232 PSI)

$\Delta p (p_3 - p_1)$  ideal = 2 ... 3 bar (29 ... 44 PSI)

$\Delta p (p_3 - p_1)$  max = 16 bar (232 PSI)

API Plan 53/54

Pump startup:

$\Delta p (p_3 - p_1)$  max = 16 bar (232 PSI) allowed

## Dimensional Data

### Dimensions in millimeter

$d_1$	$d_2$	$d_3$ min.	$d_3$ max.	$l_4$	$l_5$	$l_6$	$l_7$	$d_a$	$a_2$	$s$	Connection
25	45.0	47.0	51.0	25.4	87.0	33.6	53.4	105.0	62.0	13.2	1/4 NPT
30	49.4	52.0	56.0	25.4	86.5	33.1	53.4	105.0	67.0	13.2	1/4 NPT
32	52.3	54.5	57.0	25.4	86.5	33.1	53.4	108.0	70.0	13.2	1/4 NPT
33	52.3	54.5	57.0	25.4	86.5	33.1	53.4	108.0	70.0	13.2	1/4 NPT
35	54.8	58.0	61.5	25.4	86.5	33.1	53.4	113.0	72.0	13.2	1/4 NPT
38	57.5	60.0	66.0	25.4	86.5	33.1	53.4	123.0	75.0	14.0	3/8 NPT
40	58.8	62.0	68.0	25.4	86.3	32.9	53.4	123.0	77.0	14.2	3/8 NPT
43	61.9	64.5	70.5	25.4	86.5	33.1	53.4	133.0	80.0	14.2	3/8 NPT
45	65.0	68.5	73.0	25.4	86.5	33.1	53.4	138.0	82.0	14.2	3/8 NPT
48	68.4	71.0	75.0	25.4	86.8	33.4	53.4	138.0	85.0	14.2	3/8 NPT
50	70.0	73.0	78.0	25.4	87.2	33.8	53.4	148.0	87.0	14.2	3/8 NPT
53	71.9	75.0	87.0	25.4	87.4	34.0	53.4	148.0	97.0	18.0	3/8 NPT
55	74.6	77.0	83.0	25.4	87.0	33.6	53.4	148.0	92.0	18.0	3/8 NPT
60	83.9	87.0	91.0	25.4	88.2	34.8	53.4	157.0	102.0	18.0	3/8 NPT
65	87.5	90.0	98.5	25.4	88.1	34.7	53.4	163.0	109.3	18.0	3/8 NPT
70	93.0	98.0	108.0	25.4	89.6	36.2	53.4	178.0	118.3	18.0	3/8 NPT
75	96.8	101.6	118.0	28.0	107.4	43.5	63.9	190.0	129.0	18.0	3/8 NPT
80	104.7	108.0	124.0	28.0	106.8	42.9	63.9	195.0	135.0	18.0	3/8 NPT

**Note:** Additional technical & dimensional information will be provided on request.

The specifications, drawings, images etc included in this catalogue are intended to be generic and must be interpreted as equivalent or functionally equivalent, more specifically the performance capabilities mentioned in this catalogue is based on optimum values, however the performance of the product is dependent on size, material of construction, media, pressure, temperature, sliding velocity etc and it shall vary from size to size or application to application. Customers are requested to consult with Sealmatic before employing the product from this catalogue for any application.



### Product Description

1. Single and Dual seal configuration
2. Balanced design
3. Independent of direction of rotation
4. Cartridge construction
5. Seal design in accordance with API 682 / ISO 21049
6. Conforming to Category 1, Type A, Arrangement 1, 2 or 3
7. Single seal with API Plan 11 and 61
8. Dual seals with API Plan 52 / 53
9. Robust construction with shrink-fitted seal faces
10. Heavy duty solid seat design
11. Also available in design variation for independent of direction of rotation
12. Additional flushing plans available on request

### Technical Features

1. Designed to accommodate shaft deflections and process fluctuations
2. Efficient construction for heat dissipation
3. Compact installation design
4. Factory assembled cartridge unit for easy installation
5. Springs are product protected to avoid contamination
6. Can accommodate reverse pressure
7. Can handle extensive applications in various temperatures and pressures
8. Versatile in design to fit various seal chambers

### Typical Industrial Applications

Chemical industry  
 Light volatile and highly viscous hydrocarbons  
 Low solids content and low abrasive media  
 Media with poor lubrication properties  
 Oil and gas industry  
 Petrochemical industry  
 Toxic and hazardous media  
 Standard pumps  
 Vertical and horizontal ANSI chemical pumps

### Standards

API 682 / ISO 21049

### Materials

Seal face: Carbon graphite antimony impregnated (A), Silicon carbide sintered pressureless (Q12)  
 Seat: Silicon carbide sintered pressureless (Q1)  
 Secondary seals: FKM (V), FFKM (K), NBR (P), EPDM (E)  
 Springs: Hastelloy® C-4 (M)\* and C-276 (M5)  
 Metal parts: CrNiMo steel (G)

### Performance Capabilities

Sizes:  $d_1$  = Upto 110 mm (Upto 4.250")  
 other sizes on request  
 Pressure:  $p_1$  = 22 bar (319 PSI)  
 Temperature:  $t$  = -40 °C...+260 °C  
 (-40 °F...+500 °F)  
 Speed = 23 m/s (75 ft/s)

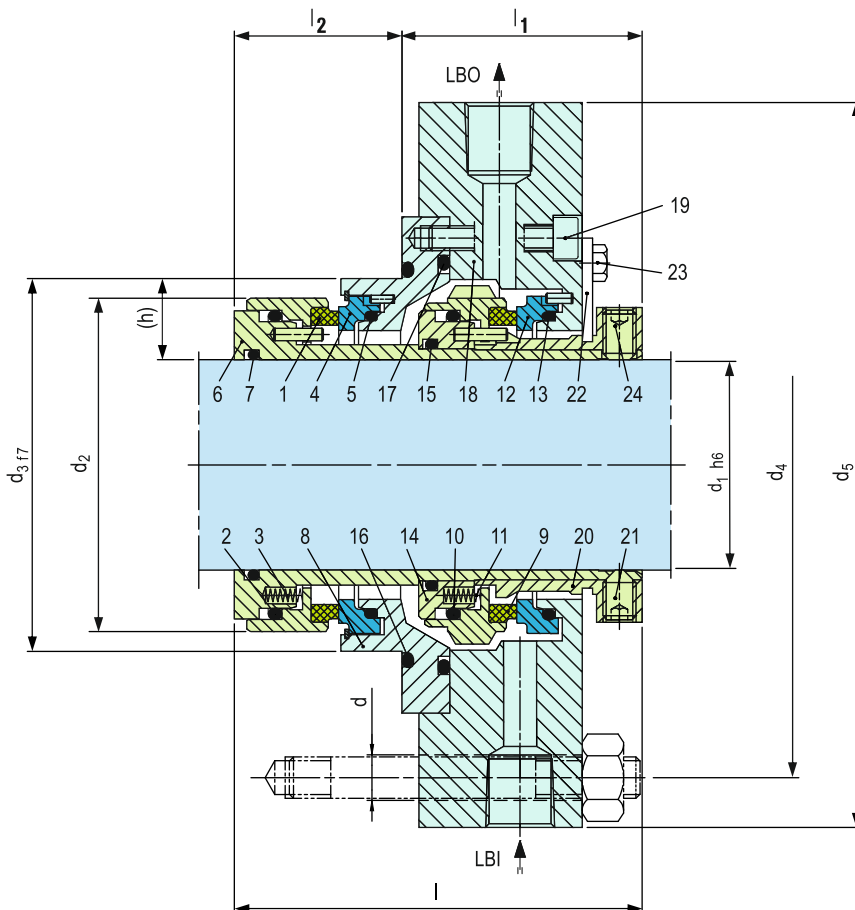

Note: The item numbers as depicted above are based on our technical experience and knowledge and are placed in the chronological order of their assembly procedure.

Item	Description
1, 9	Seal face
2, 5, 7, 10, 13, 15, 16, 17	O-ring
3, 11	Spring
4, 12	Seat
6	Shaft sleeve
8	Adapter
14	Driver
18	Housing
19	HSH Cap screw
20	Set ring
21	Set screw
22	Assembly fixture
23	Hexagon bolt
24	Set screw

## Design Variations

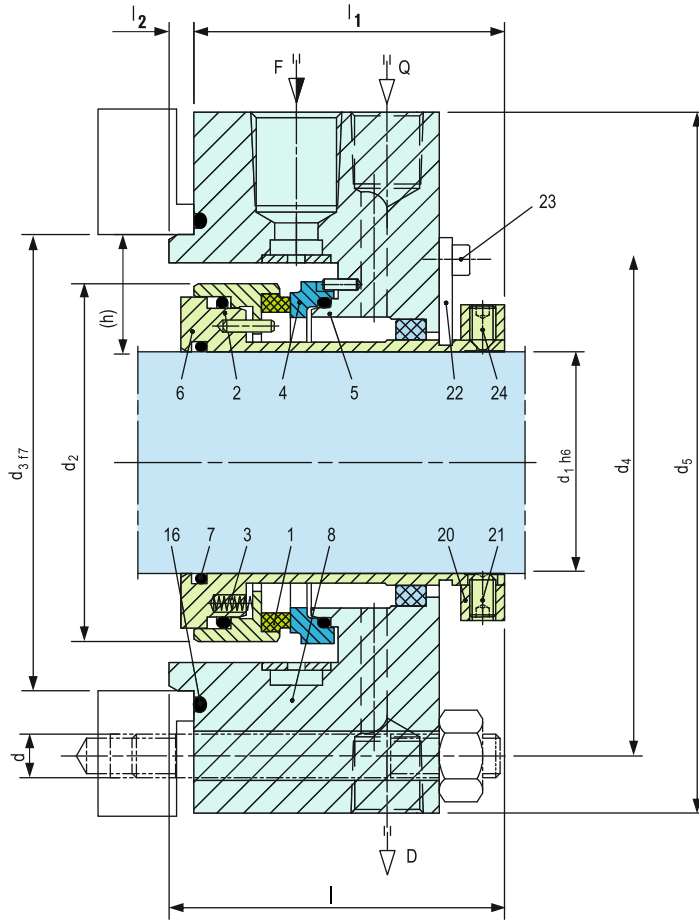

**CTXAPI-SA**  
Single Seal

## Dimensional Data

### Dimensions in millimeter

d <sub>1</sub>	d <sub>2</sub>	d <sub>3</sub>	d <sub>4</sub>	d <sub>5</sub>	l	l <sub>1</sub>	l <sub>2</sub>	d	n	acc. to ASME B73.1 (h min)
20	50.4	58	105	127	96.5	68.5	28	13.5	4	19.05
25	55.4	63	110	132	96.5	68.5	28	13.5	4	19.05
30	60.4	68	115	137	96.5	68.5	28	13.5	4	19.05
35	65.4	73	120	142	96.5	68.5	28	13.5	4	19.05
40	70.4	78	125	147	96.5	68.5	28	13.5	4	19.05
45	75.4	83	135	162	96.5	68.5	28	17.5	4	19.05
50	80.4	88	140	167	100	72	28	17.5	4	19.05
55	85.4	93	145	172	100	72	28	17.5	4	19.05
60	96	105	160	187	127.5	88	39.5	17.5	4	22.22
65	101	110	165	192	127.5	88	39.5	17.5	4	22.22
70	106	115	170	197	127.5	88	39.5	17.5	4	22.22
75	111	120	175	202	127.5	88	39.5	17.5	4	22.22
80	116	125	185	213	127.5	88	39.5	22	4	22.22
85	123.5	136	190	223	131.5	92	39.5	22	4	25.4
90	128.5	141	195	228	131.5	92	39.5	22	4	25.4
95	133.5	146	200	233	131.5	92	39.5	22	4	25.4
100	138.5	151	205	238	131.5	92	39.5	22	4	25.4
105	143.5	156	210	243	131.5	92	39.5	22	4	25.4
110	152.5	161	215	248	131.5	92	39.5	22	4	25.4

inch size available from size 0.750 to 4.250

**Note: Additional technical & dimensional information will be provided on request.**

The specifications, drawings, images etc included in this catalogue are intended to be generic and must be interpreted as equivalent or functionally equivalent, more specifically the performance capabilities mentioned in this catalogue is based on optimum values, however the performance of the product is dependent on size, material of construction, media, pressure, temperature, sliding velocity etc and it shall vary from size to size or application to application. Customers are requested to consult with Sealmatic before employing the product from this catalogue for any application.

# VTX Single Seals

# For Eccentric Screw Pumps - Standard Cartridge Seals



### Product Description

1. Single seal configuration
2. Balanced design
3. Independent of direction of rotation
4. Cartridge construction

### Technical Features

1. Ideal for use in process pump standardization
2. O-ring is dynamically loaded to prevent shaft damage.
3. Dimensional modification of the stuffing box chamber is not required due to short radial installation height
4. Ideal to convert and retrofit pumps with packings and large volume OEM production
5. Cartridge unit factory assembled for easy installation, which reduces down-time
6. Rugged design for long operating life

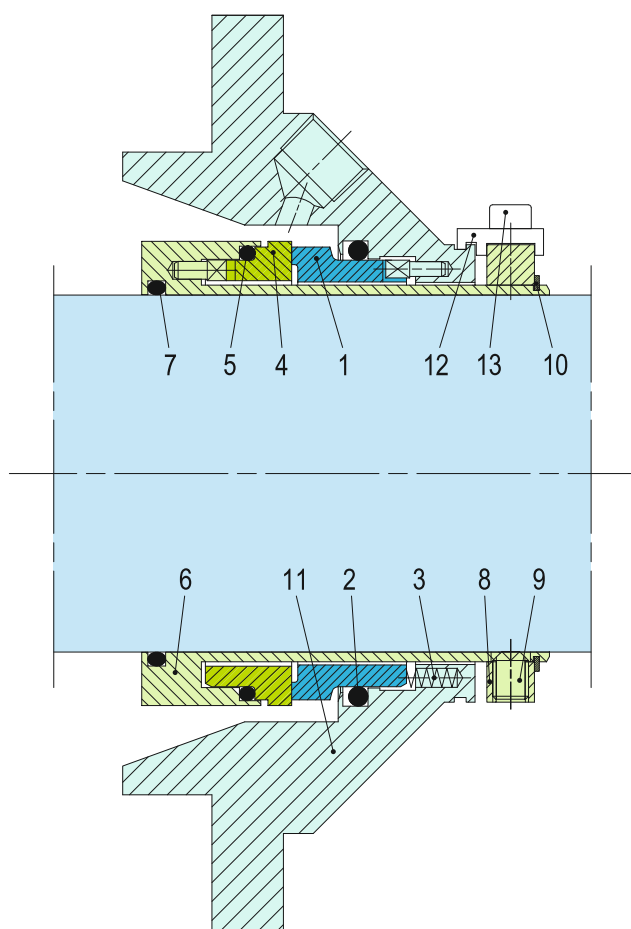

Note: The item numbers as depicted above are based on our technical experience and knowledge and are placed in the chronological order of their assembly procedure.

Item	Description
1	Seal face
2, 5, 7	O-ring
3	Spring
4	Seat
6	Shaft sleeve
8	Drive collar
9	Set screw

Item	Description
10	Snap ring
11	Cover
12	Assembly fixture
13	HSH Cap Screw

### VTX

CTX seals with modified cover for eccentric screw pumps.

Example Pumps: Seepex BN, Netzsch NM...S, NM...B, NE (P), Allweiler AE, AEB, AED, Robbins & Myers / Moyno 2000 CC, and Mono E-Range.

### Typical Industrial Applications

Foodstuffs and animal feed industries  
 Sweet cider pressing and beverage production  
 Viticulture and wineries  
 Spirit production and alcohol industry  
 Breweries and malt houses  
 Sugar industry  
 Pharmaceuticals and cosmetics industry  
 Oil and gas industry  
 Pulp and paper production  
 Paint and lacquer industry  
 Chemicals industry  
 Automobile industry  
 Water and wastewater industry

### Materials

Seal face: Silicon carbide (Q1), Carbon graphite resin impregnated (B), Tungsten carbide (U2)  
 Seat: Silicon carbide (Q1)  
 Secondary seals: FKM (V), EPDM (E), FFKM (K), Perfluorocarbon rubber/PTFE (U1)  
 Springs: Hastelloy® C-4 (M)  
 Metal parts: CrNiMo steel (G), CrNiMo cast steel (G)

### Performance Capabilities

VTX-SN, -SNO, -QN, -TN  
 Sizes: Upto 100 mm (Upto 4.000")  
 Other sizes on request  
 Temperature:  $t = -40\text{ }^{\circ}\text{C} \dots +220\text{ }^{\circ}\text{C}$   
 ( $-40\text{ }^{\circ}\text{F} \dots +428\text{ }^{\circ}\text{F}$ )  
 (Check O-ring resistance)

#### Sliding face material combination Bq1

Pressure:  $p_s = 25\text{ bar}$  (363 PSI)  
 Speed = 16 m/s (52 ft/s)

#### Sliding face material combination Q1Q1 or U2Q1

Pressure:  $p_s = 12\text{ bar}$  (175 PSI)  
 Speed = 10 m/s (33 ft/s)  
 Permissible axial movement:  $\pm 1.0\text{ mm}$ ,  
 $d_i \geq 75\text{ mm} \pm 1.5\text{ mm}$

The specifications, drawings, images etc included in this catalogue are intended to be generic and must be interpreted as equivalent or functionally equivalent, more specifically the performance capabilities mentioned in this catalogue is based on optimum values, however the performance of the product is dependent on size, material of construction, media, pressure, temperature, sliding velocity etc and it shall vary from size to size or application to application. Customers are requested to consult with Sealmatic before employing the product from this catalogue for any application.



# VTX Dual Seals

# For Eccentric Screw Pumps - Standard Cartridge Seals



### Product Description

1. Dual seal configuration
2. Balanced design
3. Independent of direction of rotation
4. Cartridge construction
5. Double pressure balanced
6. Designed with integrated pumping device for increased efficiency in circulation
7. Suitable for eccentric screw pumps

### Technical Features

1. Ideal for use in process pump standardization
2. O-ring is dynamically loaded to prevent shaft damage.
3. Dimensional modification of the stuffing box chamber is not required due to short radial installation height
4. Ideal to convert and retrofit pumps with packings and large volume OEM production
5. Cartridge unit factory assembled for easy installation, which reduces down-time
6. Rugged design for long operating life

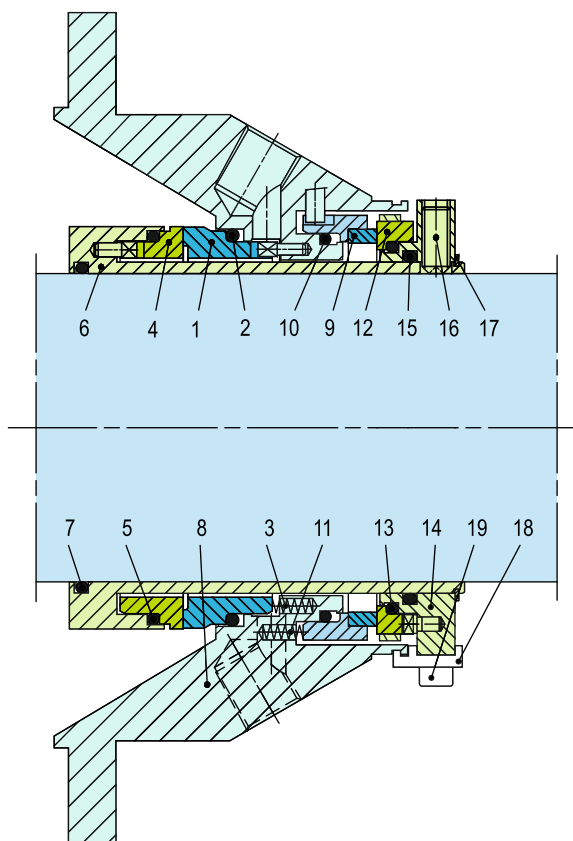

**Note:** The item numbers as depicted above are based on our technical experience and knowledge and are placed in the chronological order of their assembly procedure.

Item	Description
1	Seal face
2, 5, 7	O-ring
10, 13, 15	
3	Spring
4, 12	Seat
6	Shaft sleeve
8	Cover

Item	Description
9	Seal Face
11	Spring
14	Driver
16	Set screw
17	Retaining Ring
18	Assembly Fixture
19	HSH Cap Screw

### VTX

CTX seals with modified cover for eccentric screw pumps.

Example Pumps: Seepex BN, Netzsch NM...S, NM...B, NE (P), Allweiler AE, AEB, AED, Robbins & Myers / Moyno 2000 CC, and Mono E-Range.

### Typical Industrial Applications

- Foodstuffs and animal feed industries
- Sweet cider pressing and beverage production
- Viticulture and wineries
- Spirit production and alcohol industry
- Breweries and malt houses
- Sugar industry
- Pharmaceuticals and cosmetics industry
- Oil and gas industry
- Pulp and paper production
- Paint and lacquer industry
- Chemicals industry
- Automobile industry
- Water and wastewater industry

### Materials

Seal face: Silicon carbide (Q1), Carbon graphite resin impregnated (B), Tungsten carbide (U2)  
 Seat: Silicon carbide (Q1)  
 Secondary seals: FKM (V), EPDM (E), FFKM (K), Perfluorocarbon rubber/PTFE (U1)  
 Springs: Hastelloy® C-4 (M)  
 Metal parts: CrNiMo steel (G), CrNiMo cast steel (G)

### Performance Capabilities

Sizes: Upto 140mm (Upto 5.500")  
 Other sizes on request  
 Temperature : t= -40 °C...+220 °C  
 (-40 °F...+428 °F)  
 (Check O-ring resistance)

### Sliding face material combination BQ1

Pressure:  $p_1 = 25$  bar (363 PSI)  
 Speed = 16 m/s (52 ft/s)

### Sliding face material combination Q1Q1 or U2Q1

Pressure:  $p_1 = 12$  bar (175 PSI)  
 Speed = 10 m/s (33 ft/s)  
 Permissible axial movement:  $\pm 1.0$  mm,  
 $d_1 \geq 75$  mm  $\pm 1.5$  mm

The specifications, drawings, images etc included in this catalogue are intended to be generic and must be interpreted as equivalent or functionally equivalent, more specifically the performance capabilities mentioned in this catalogue is based on optimum values, however the performance of the product is dependent on size, material of construction, media, pressure, temperature, sliding velocity etc and it shall vary from size to size or application to application. Customers are requested to consult with Sealmatic before employing the product from this catalogue for any application.



### Product Description

1. Single seal configuration
2. Balanced design
3. Independent of direction of rotation
4. Cartridge construction
5. Category 2 and 3, Type A, Arrangement 1
6. Design in accordance to API 682 / ISO 21049
7. Pumping device available for increased efficiency in circulation (B750VP)
8. Rotary unit with multiple springs

### Technical Features

1. Designed for "Low-Emission" conforming to the American STLE-limits
2. Can handle extensive applications in various temperatures and pressures
3. Versatile in design to fit various seal chambers
4. Material of construction available in special metallurgy

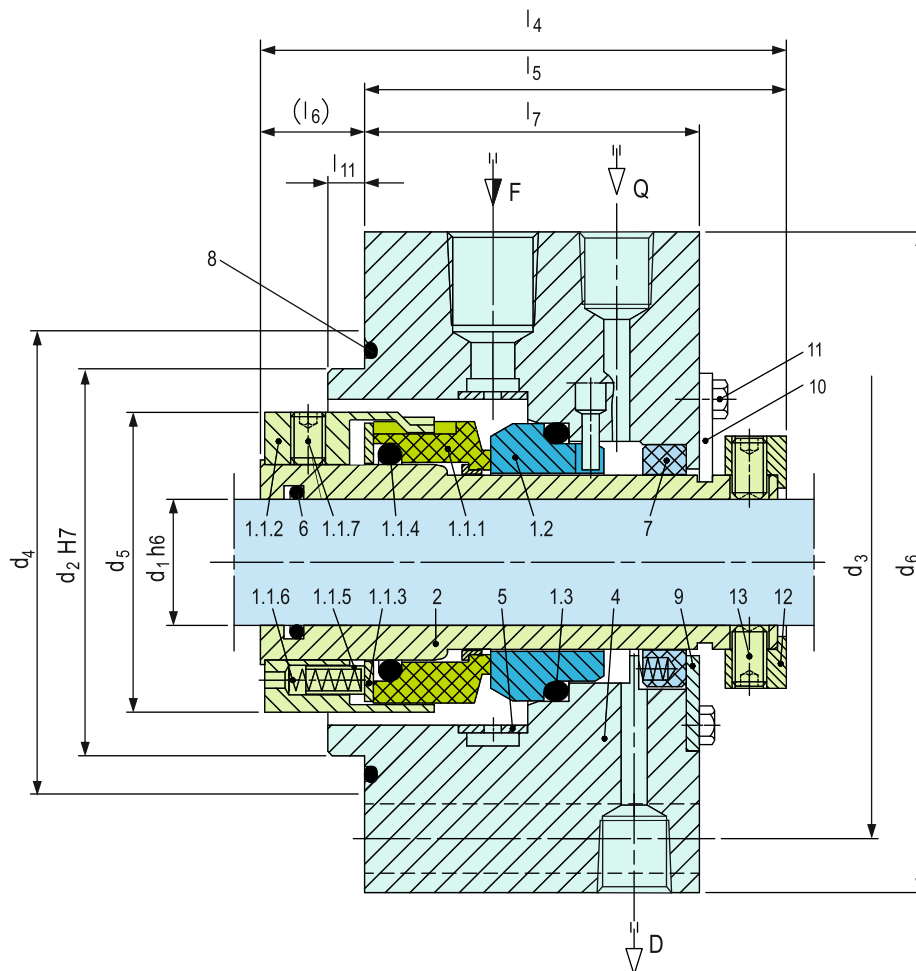

Item	Description
1.1.1	Seal face
1.1.2	Driver
1.1.3	Thrust ring
1.1.4, 1.3, 6, 8	O-ring
1.1.5	Sleeve
1.1.6	Spring
1.1.7	Set screw
1.2	Seat

Item	Description
2	Shaft sleeve
4	Housing
5	Insert
7	Throttle ring
9	Washer
10	Assembly fixture
11	Hexagon bolt
12	Set ring
13	Set screw

### Typical Industrial Applications

Light hydrocarbons  
Oil and gas industry  
Petrochemical industry  
Refining technology  
API 610 / ISO 13709 pumps  
Process pumps

### Performance Capabilities

Sizes: d = Upto 110 mm (Upto 4.250")\*  
Pressure:  $p_1 = 40$  bar (580 PSI)  
Temperature:  $t = -40$  °C...+220 °C  
(-40 °F...+428 °F)  
Speed = 23 m/s (75 ft/s)  
Permissible axial movement:  $\pm 2.0 \dots 4.0$  mm  
depending on diameter and installation  
situation  
\* Other sizes on request

### Standards

API 682/ ISO 21049

### Materials

Seal face: Carbon graphite antimony  
impregnated (A)  
Seat: Silicon carbide (Q1, Q2)  
Secondary seals: EPDM (E), NBR (P),  
FKM (V), FFKM (K)  
Springs: Hastelloy® C-4 (M)  
Metal parts: CrNiMo steel (G), Duplex (G1),  
Hastelloy® C-4 (M)

### Design Variations

#### B750VP

Dimensions, items and descriptions as B750VN,  
but with pumping ring. Shorter installation length  
possible.

#### B750N

Dimensions, items and description as B750VN.  
Seal face: Silicon carbide (Q1, Q2)  
Seat: Silicon carbide (Q1, Q2)

### Dimensional Data

#### Dimensions in inch

API/d <sub>1</sub>	API/d <sub>2</sub>	API/d <sub>3</sub>	API/d <sub>4</sub>	d <sub>5</sub>	d <sub>6</sub>	l <sub>4</sub>	l <sub>5</sub>	l <sub>6</sub>	l <sub>7</sub>	l <sub>11</sub>	Overall length
0.750	2.756	4.134	3.346	1.969	5.433	3.740	3.701	0.039	2.992	0.236	3.937
1.125	3.150	4.528	3.740	2.441	5.827	3.957	3.858	0.098	3.031	0.236	4.094
1.500	3.543	4.921	4.134	2.835	6.220	4.154	3.878	0.276	3.051	0.236	4.921
2.000	3.937	5.512	4.528	3.386	6.614	4.390	3.917	0.472	3.091	0.236	5.512
2.250	4.724	6.299	5.315	3.898	7.402	4.744	4.016	0.728	3.189	0.236	6.299
2.750	5.118	6.693	5.709	4.291	7.795	4.902	4.173	0.709	3.189	0.236	6.693
3.125	5.512	7.087	6.102	4.685	8.189	5.079	4.173	0.906	3.189	0.236	7.087
3.500	6.299	8.071	6.890	5.079	9.370	5.079	4.173	0.906	3.189	0.236	8.071
3.750	6.693	8.465	7.283	6.024	9.764	5.236	4.291	0.945	3.189	0.236	8.465
4.250	7.087	8.858	7.677	6.614	10.157	5.236	4.291	0.945	3.189	0.236	8.858

#### Dimensions in millimeter

API/d <sub>1</sub>	API/d <sub>2</sub>	API/d <sub>3</sub>	API/d <sub>4</sub>	d <sub>5</sub>	d <sub>6</sub>	l <sub>4</sub>	l <sub>5</sub>	l <sub>6</sub>	l <sub>7</sub>	l <sub>11</sub>	Overall length
20	70	105	85	50	138	95.0	94.0	1.0	76.0	6	100
30	80	115	95	62	148	100.5	98.0	2.5	77.0	6	104
40	90	125	105	72	158	105.5	98.5	7.0	77.5	6	125
50	100	140	115	86	168	111.5	99.5	12.0	78.5	6	140
60	120	160	135	99	188	120.5	102.0	18.5	81.0	6	160
70	130	170	145	109	198	124.5	106.0	18.0	81.0	6	170
80	140	180	155	119	208	129.0	106.0	23.0	81.0	6	180
90	160	205	175	129	238	129.0	106.0	23.0	81.0	6	205
100	170	215	185	153	248	133.0	109.0	24.0	81.0	6	215
110	180	225	195	168	258	133.0	109.0	24.0	81.0	6	225

Note: Additional technical & dimensional information will be provided on request.

The specifications, drawings, images etc included in this catalogue are intended to be generic and must be interpreted as equivalent or functionally equivalent, more specifically the performance capabilities mentioned in this catalogue is based on optimum values, however the performance of the product is dependent on size, material of construction, media, pressure, temperature, sliding velocity etc and it shall vary from size to size or application to application. Customers are requested to consult with Sealmatic before employing the product from this catalogue for any application.



### Product Description

1. Dual seal configuration
2. Balanced design
3. Independent of direction of rotation
4. Cartridge construction
5. Bi-directional design available
6. Category 2 and 3, Type A, Arrangement 2 or 3
7. Design in accordance to API 682 / ISO 21049
8. Pumping device available for increased efficiency in circulation
9. Rotary unit with multiple springs
10. Can accommodate reverse pressure

### Technical Features

1. Can handle extensive applications in various temperatures and pressures
2. Versatile in design to fit various seal chambers
3. Material of construction available in special metallurgy
4. Special torque transmission design for high performance
5. Operation reliability due to rugged metal torque transmission at the rotating seal face

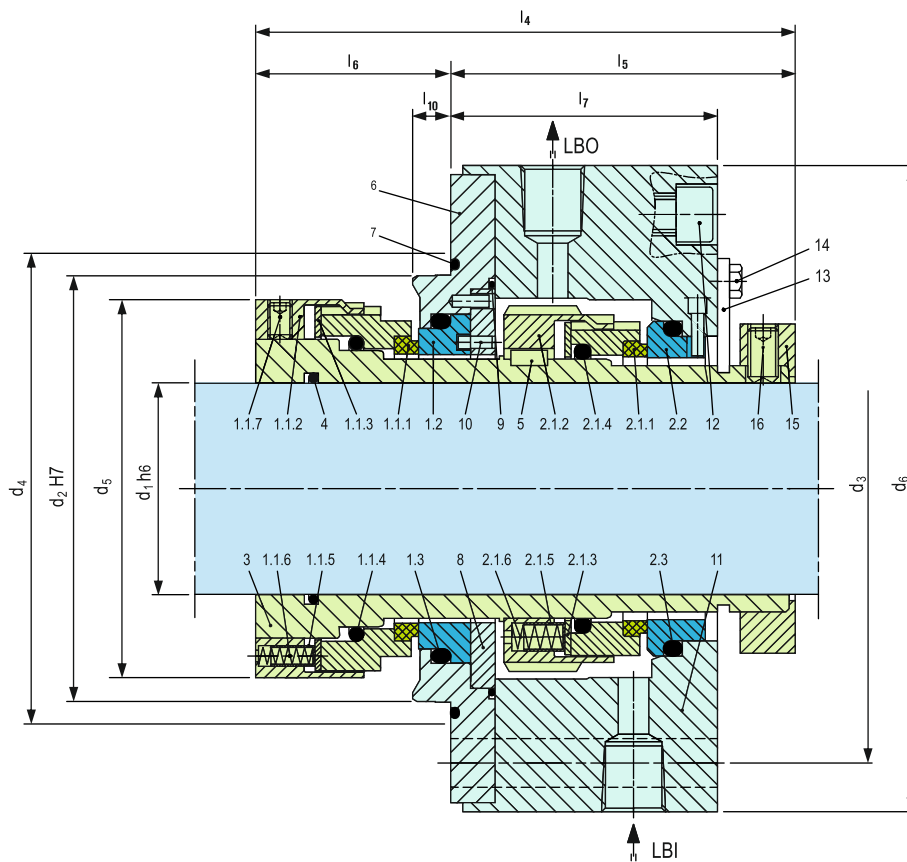

Item	Description
1.1.1, 2.1.1	Seal face
1.1.2, 2.1.2	Driver
1.1.3, 2.1.3	Thrust ring
1.1.4, 2.1.4, 1.3, 2.3	O-ring
1.1.5, 2.1.5	Spring Sleeve
1.1.6, 2.1.6	Spring
1.1.7	Set screw
1.2, 2.2	Seat
3	Shaft sleeve
4	O-ring
5	Key

Item	Description
6	Adapter
7	O-ring
8	Washer
9	O-ring
10	Pin
11	Housing
12	HSH cap screw
13	Assembly fixture
14	Hexagon bolt
15	Set ring
16	Set screw

### Typical Industrial Applications

Light volatile and highly viscous hydrocarbons  
Oil and gas industry  
Petrochemical industry  
Refining technology  
API 610 / ISO 13709 pumps  
Process pumps

### Performance Capabilities

Sizes:  $d_1$  = Upto 110 mm (Upto 4.250")\*  
Pressure:  $p_1$  = 40 bar (580 PSI)  
Temperature:  $t$  = -40 °C...+220 °C  
(-40 °F...+428 °F)  
Speed = 23 m/s (75 ft/s)  
Permissible axial movement:  $\pm 2.0 \dots 4.0$  mm  
depending on diameter and installation  
situation  
\* Other sizes on request

### Standards

API 682 / ISO 21049

### Materials

Seal face: Carbon graphite antimony  
impregnated (A), Silicon carbide (Q1, Q2)  
Seat: Silicon carbide (Q1, Q2)  
Secondary seals: EPDM (E), NBR (P),  
FKM (V), FFKM (K)  
Springs: Hastelloy® C-4 (M)  
Metal parts: CrNiMo steel (G), Duplex (G1),  
Hastelloy® C-4 (M)

### Design Variations

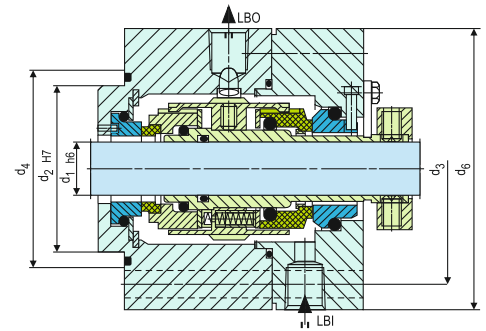

### B750VK-D

Dual seal in back-to-back arrangement.  
Suitable for API 610 table 6 seal chambers.

### Dimensional Data

#### Dimensions in inch

API/d <sub>1</sub>	API/d <sub>2</sub>	API/d <sub>3</sub>	API/d <sub>4</sub>	d <sub>5</sub>	d <sub>6</sub>	l <sub>4</sub>	l <sub>5</sub>	l <sub>6</sub>	l <sub>7</sub>	l <sub>10</sub>	Axial movement
0.750	2.756	4.134	3.346	2.362	5.079	5.669	3.819	1.850	3.189	0.236	±0.079
1.125	3.150	4.528	3.740	2.756	5.472	5.728	3.780	1.949	3.051	0.315	±0.079
1.500	3.543	4.921	4.134	3.228	5.866	5.768	3.799	1.969	3.071	0.315	±0.079
2.000	3.937	5.512	4.528	3.701	6.614	6.220	4.193	2.028	3.465	0.413	±0.079
2.250	4.724	6.299	5.315	4.488	7.402	6.496	4.232	2.264	3.551	0.177	±0.079
2.750	5.118	6.693	5.709	4.882	7.795	6.693	4.232	2.461	3.346	0.394	±0.079
3.125	5.512	7.087	6.102	5.276	8.189	6.890	4.232	2.657	3.346	0.492	±0.079
3.500	6.299	8.071	6.890	5.748	9.370	7.039	4.602	2.437	3.717	0.272	±0.118
3.750	6.693	8.465	7.283	6.417	9.764	7.283	4.626	2.657	3.622	0.453	±0.079
4.250	7.087	8.858	7.677	6.811	10.157	7.402	4.587	2.815	3.583	0.610	±0.118

#### Dimensions in millimeter

API/d <sub>1</sub>	API/d <sub>2</sub>	API/d <sub>3</sub>	API/d <sub>4</sub>	d <sub>5</sub>	d <sub>6</sub>	l <sub>4</sub>	l <sub>5</sub>	l <sub>6</sub>	l <sub>7</sub>	l <sub>10</sub>	Axial movement
20	70	105	85	60	129	144.0	97.0	47.0	81.0	6.0	±2.0
30	80	115	95	70	139	145.5	96.0	49.5	77.5	8.0	±2.0
40	90	125	105	82	149	146.5	96.5	50.0	78.0	8.0	±2.0
50	100	140	115	94	168	158.0	106.5	51.5	88.0	10.5	±2.0
60	120	160	135	114	188	165.0	107.5	57.5	90.2	4.5	±2.0
70	130	170	145	124	198	170.0	107.5	62.5	85.0	10.0	±2.0
80	140	180	155	134	208	175.0	107.5	67.5	85.0	12.5	±2.0
90	160	205	175	146	238	178.8	116.9	61.9	94.4	6.9	±3.0
100	170	215	185	163	248	185.0	117.5	67.5	92.0	11.5	±2.0
110	180	225	195	173	258	188.0	116.5	71.5	91.0	15.5	±3.0

**Note: Additional technical & dimensional information will be provided on request.**

The specifications, drawings, images etc included in this catalogue are intended to be generic and must be interpreted as equivalent or functionally equivalent, more specifically the performance capabilities mentioned in this catalogue is based on optimum values, however the performance of the product is dependent on size, material of construction, media, pressure, temperature, sliding velocity etc and it shall vary from size to size or application to application. Customers are requested to consult with Sealmatic before employing the product from this catalogue for any application.



### Product Description

1. Single seal in split configuration
2. Balanced design
3. Independent of direction of rotation
4. For plain shafts
5. Semi-cartridge construction
6. Built-in flushing connections
7. Designed with external pressurization
8. Factory assembled fully split single seal, 2 x 2 segments
9. Stationary design with multiple springs

### Technical Features

1. Economical to assemble as the complete dismantling of the equipment is not necessary to install the seal
2. Reduces down time due to ease in installation
3. Rugged seal construction
4. Distortion of the seat is avoided by mechanical decoupling of the clamping ring
5. Ease in installation and no modifications are required because the seal is located outside of the stuffing box.
6. Due to the stationary design and the elastic seat mounting a high tolerance of shaft deflections can be accommodated
7. Low leakage is achieved by the elimination of secondary seals which eliminates leakage paths between split components
8. Shaft is protected by uniform torque transmission through the clamping ring which prevents damage caused by set screws.
9. Springs are product protected to avoid contamination and clogging

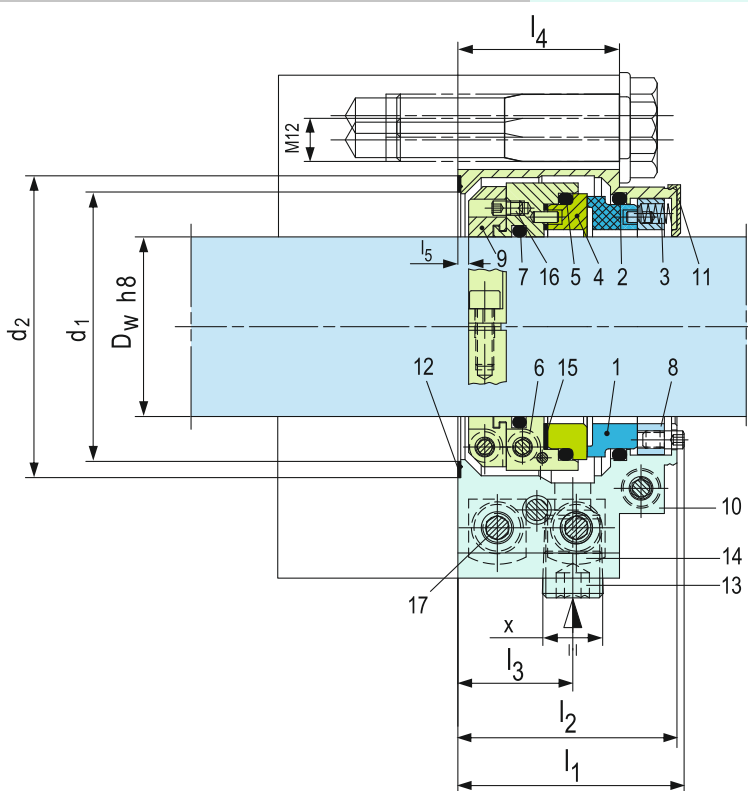

Note: The item numbers as depicted above are based on our technical experience and knowledge and are placed in the chronological order of their assembly procedure.

Item	Description
1	Seal face
2, 5, 7	O-ring
3	Spring
4	Seat
6	Driver
8	Thrust ring
9	Clamp collar
10	Housing
11	Assembly fixture
12, 15	Gasket
13	Head screw plug
14	Mounting plate
16	Set screw
17	Socket head screw

### Typical Industrial Applications

- Agitators
- Chemical Industry
- Centrifugal pumps
- Conveying pulp with stock pumps
- Cooling water pumps for energy generation
- Conveying timber to refiners with pumping screws
- Circulation of pulp-and-water mixtures in storage vessels
- Displacement pumps
- Process industry
- Petrochemical Industry
- Power Plant Technology
- Pulp and paper industry
- Pump stations for waste water treatment

### Performance Capabilities

- Shaft diameter:  $d_1 =$  Upto... 150mm (Upto... 6.000")
- Pressure:  $p_1 = 10$  bar (145 PSI)
- Temperature:  $t = -40$  °C... + 150 °C (-40 °F... + 300 °F), above 80 °C (175 °F) flush is recommended
- Speed = 10 m/s (33 ft/s)
- Axial movement:  $\pm 1.5$  mm (1/16")
- Radial movement:  $\pm 0.8$  mm (1/32")

### Materials

- Seal face: Carbon graphite antimony impregnated (A), Silicon carbide (Q2)
- Seat: Silicon carbide (Q2)
- Secondary seals: FKM (V), EPDM (E), NBR(P)
- Springs: CrNiMo steel (G)
- Metal parts: CrNiMo steel (G)

### Installation, Details, Option

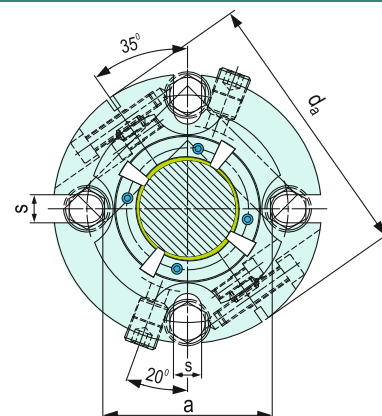

## Dimensions

### Dimensions in inch

$d_w$	$d_1$	$d_2$	$d_a$	$a$	$s$	$l_1$	$l_2$	$l_3$	$l_4$	$l_5$	$X$
2.000	2.953	3.307	5.433	3.456	0.591	2.480	2.402	1.181	1.772	0.118	3/8 NPT
2.125	3.110	3.465	5.787	3.622	0.591	2.480	2.402	1.142	1.772	0.118	3/8 NPT
2.375	3.504	3.976	5.866	4.134	0.689	2.520	2.441	1.181	1.811	0.118	3/8 NPT
2.500	3.642	4.114	6.181	4.272	0.689	2.520	2.441	1.181	1.811	0.118	3/8 NPT
2.750	3.858	4.449	6.929	4.646	0.787	2.520	2.441	1.181	1.811	0.118	3/8 NPT
3.000	4.094	4.803	7.638	5.000	0.787	2.559	2.480	1.339	1.850	0.118	3/8 NPT
3.250	4.331	5.197	7.520	5.315	0.787	2.559	2.480	1.220	1.850	0.118	3/8 NPT
3.500	4.764	5.512	7.992	5.709	0.866	2.854	2.776	1.240	1.988	0.118	1/2 NPT
3.750	4.921	5.630	8.110	5.827	0.866	2.854	2.776	1.240	1.988	0.118	1/2 NPT
4.000	5.157	5.906	8.504	6.102	0.866	2.854	2.776	1.240	1.988	0.118	1/2 NPT
4.250	5.591	6.496	9.055	6.693	0.866	2.854	2.776	1.240	1.988	0.118	1/2 NPT
4.500	5.984	6.890	9.449	7.087	0.866	2.854	2.776	1.240	1.988	0.118	1/2 NPT
4.750	5.984	6.890	9.449	7.087	0.866	2.854	2.776	1.240	1.988	0.118	1/2 NPT
5.000	6.378	7.283	10.551	7.480	1.024	3.524	3.445	1.713	2.461	0.157	1/2 NPT
5.500	6.890	7.874	11.929	8.071	1.024	3.524	3.445	1.713	2.461	0.157	1/2 NPT
6.000	7.402	8.465	12.126	8.661	1.024	3.524	3.445	1.713	2.461	0.157	1/2 NPT

### Dimensions in millimeter

$d_w$	$d_1$	$d_2$	$d_a$	$a$	$s$	$l_1$	$l_2$	$l_3$	$l_4$	$l_5$	$X$
50	75	84	138	88	15	63	61	30	45	3	3/8 NPT
60	89	101	149	105	17,5	64	62	30	46	3	3/8 NPT
70	98	113	176	118	20	64	62	30	46	3	3/8 NPT
80	110	132	191	135	20	65	63	31	47	3	3/8 NPT
90	121	140	203	145	22	72.5	70.5	31.5	50.5	3	1/2 NPT
100	131	150	216	155	22	72.5	70.5	31.5	50.5	3	1/2 NPT
110	142	165	230	170	22	72.5	70.5	31.5	50.5	3	1/2 NPT
120	152	175	240	180	22	72.5	70.5	32.5	50.5	3	1/2 NPT
125	162	185	268	190	26	89.5	87.5	43.5	62.5	4	1/2 NPT
140	175	200	303	205	26	89.5	87.5	43.5	62	4	1/2 NPT
150	188	215	308	220	26	89.5	87.5	43.5	62.5	4	1/2 NPT

**Note: Additional technical & dimensional information will be provided on request.**

The specifications, drawings, images etc included in this catalogue are intended to be generic and must be interpreted as equivalent or functionally equivalent, more specifically the performance capabilities mentioned in this catalogue is based on optimum values, however the performance of the product is dependent on size, material of construction, media, pressure, temperature, sliding velocity etc and it shall vary from size to size or application to application. Customers are requested to consult with Sealmatic before employing the product from this catalogue for any application.



### Product Description

1. Single seal in semi split configuration
2. Balanced design
3. Independent of direction of rotation
4. For plain shafts
5. Rotary unit with multiple springs

### Technical Features

1. Economical to assemble as the complete dismantling of the equipment is not necessary to install the seal
2. Reduces down time due to ease in installation
3. Rugged seal construction
4. Versatile split seat can be used on both the sides
5. Springs are product protected to avoid contamination

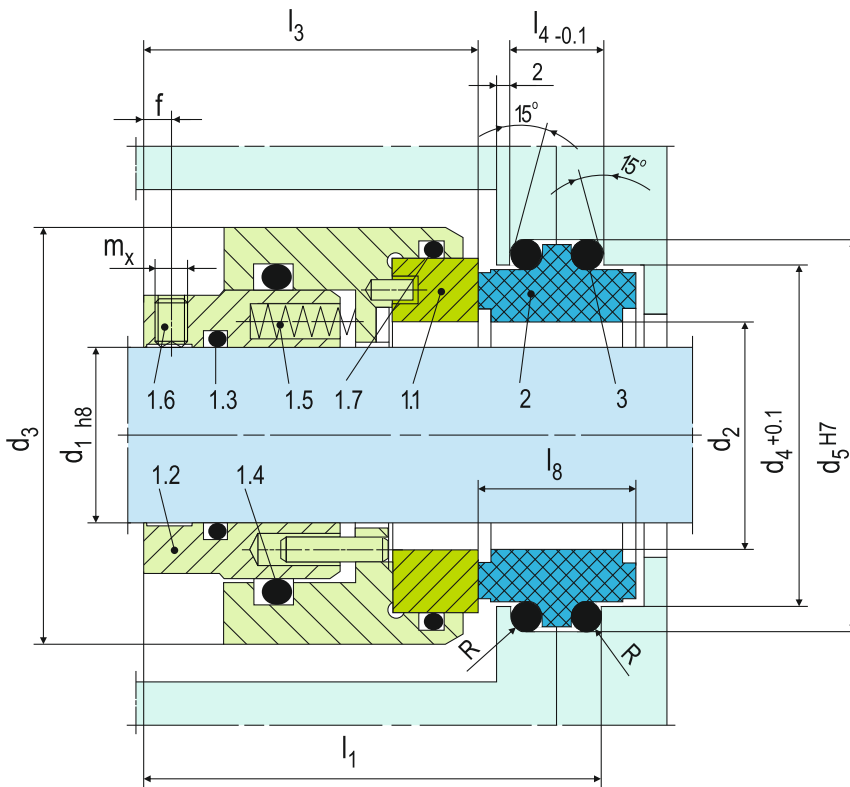

Note: The item numbers as depicted above are based on our technical experience and knowledge and are placed in the chronological order of their assembly procedure.

Item	Description
1.1	Seal face <sup>1)</sup>
1.2	Driver collar
1.3	O-ring <sup>1)</sup>
1.4	O-ring <sup>1)</sup>
1.5	Spring
1.6	Set screw
1.7	O-ring <sup>1)</sup>
2	Stationary seat <sup>1)</sup>
3	O-ring <sup>1)</sup>

<sup>1)</sup> For disassembly of unsplit seal faces, seats and O-ring should be broken or cut.

### Typical Industrial Applications

Chest agitators  
Cooling water pumps  
Defibrators  
Gears  
Power plant technology  
Pulp and paper industry  
Sea water desalination  
Shipbuilding  
Stern tubes  
Water and waste water technology  
Water turbines

### Performance Capabilities

Sizes:  $d_1 =$  Upto 310 mm (Upto 12.250")  
Pressure:  $p_1 =$  25 bar (363 PSI)  
Temperature:  $t_1 =$  150 °C (302 °F)  
Speed = 20 m/s (66 ft/s)  
Permissible axial movement:  $\pm$  2.0 mm

### Materials

Seal face: Silicon carbide (Q1)  
Seat: Silicon carbide (Q1, Q2), Carbon graphite antimony impregnated (A), Carbon graphite resin impregnated (B)  
Secondary seals: FKM (V), EPDM (E), NBR (P)  
Metal parts: CrNiMo steel (G)

### Torque Transmissions

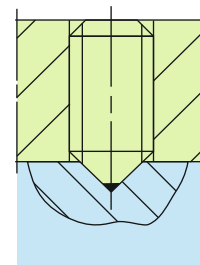

$d_1 \geq 105$  mm  
Set screws with cone points 4 x offset by 90°



## Design Variations

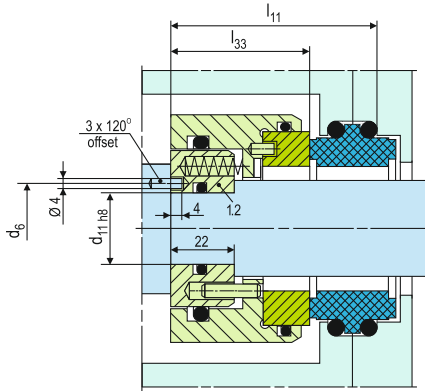

### BGH211

Dimensions, items and descriptions as BGH201. Item 1.2 driver collar is modified for securing on stepped shafts.

Unsplit as original equipment: Designation BGH210.

## Dimensional Data

Dimensions in millimeter

d <sub>1</sub>	d <sub>11</sub>	d <sub>2</sub>	d <sub>3</sub>	d <sub>4</sub>	d <sub>5</sub>	d <sub>6</sub>	l <sub>1</sub>	l <sub>11</sub>	l <sub>3</sub>	l <sub>33</sub>	l <sub>4</sub>	l <sub>8</sub>	R	f	m <sub>x</sub>
50	40	60	95	80.5	89.6	55	95.3	75.3	70	50	18.8	31.8	2.5	6	M8
55	45	65	100	85.5	94.6	60	95.3	75.3	70	50	18.8	31.8	2.5	6	M8
60	50	70	105	90.5	99.6	65	95.3	75.3	70	50	18.8	31.8	2.5	6	M8
65	55	75	110	95.5	104.6	70	95.3	75.3	70	50	18.8	31.8	2.5	6	M8
70	60	80	115	100.5	109.6	75	95.3	75.3	70	50	18.8	31.8	2.5	6	M8
75	65	85	120	105.5	114.6	80	95.3	75.3	70	50	18.8	31.8	2.5	6	M8
80	70	90	125	110.5	119.6	85	95.3	75.3	70	50	18.8	31.8	2.5	6	M8
85	75	95	130	115.5	124.6	90	95.3	75.3	70	50	18.8	31.8	2.5	6	M8
90	80	100	135	120.5	129.6	95	95.3	75.3	70	50	18.8	31.8	2.5	6	M8
95	85	105	140	125.5	134.6	100	95.3	75.3	70	50	18.8	31.8	2.5	6	M8
100	90	110	145	130.5	139.6	105	95.3	75.3	70	50	18.8	31.8	2.5	6	M8
105	95	115	150	135.5	144.6	110	95.3	75.3	70	50	18.8	31.8	2.5	6	M8
110	100	120	155	140.5	149.6	115	95.3	75.3	70	50	18.8	31.8	2.5	6	M8
115	105	125	160	145.5	154.6	120	95.3	75.3	70	50	18.8	31.8	2.5	6	M8
120	110	130	165	150.5	159.6	125	95.3	75.3	70	50	18.8	31.8	2.5	6	M8
125	115	135	170	155.5	164.6	130	95.3	75.3	70	50	18.8	31.8	2.5	6	M8
130	120	140	175	160.5	169.6	135	95.3	75.3	70	50	18.8	31.8	2.5	6	M8
135	125	145	180	165.5	174.6	140	95.3	75.3	70	50	18.8	31.8	2.5	6	M8
140	130	150	185	170.5	179.6	145	95.3	75.3	70	50	18.8	31.8	2.5	6	M8
145	135	155	190	175.5	184.6	150	95.3	75.3	70	50	18.8	31.8	2.5	6	M8
150	140	160	195	180.5	189.6	155	95.3	75.3	70	50	18.8	31.8	2.5	6	M8
155	145	165	200	185.5	194.6	160	95.3	75.3	70	50	18.8	31.8	2.5	6	M8
160	150	170	205	190.5	199.6	165	95.3	75.3	70	50	18.8	31.8	2.5	6	M8
165	155	175	210	195.5	204.6	170	95.3	75.3	70	50	18.8	31.8	2.5	6	M8
170	160	180	215	200.5	209.6	175	95.3	75.3	70	50	18.8	31.8	2.5	6	M8
175	165	185	220	205.5	214.6	180	95.3	75.3	70	50	18.8	31.8	2.5	6	M8
180	170	192	225	212.5	224.6	185	104.2	84.2	72	52	26.4	38.0	3.5	6	M8
185	175	197	230	217.5	229.6	190	104.2	84.2	72	52	26.4	38.0	3.5	6	M8
190	180	202	235	222.5	234.6	195	104.2	84.2	72	52	26.4	38.0	3.5	6	M8
195	185	207	240	227.5	239.6	200	104.2	84.2	72	52	26.4	38.0	3.5	6	M8
200	190	212	245	232.5	244.6	205	109.2	84.2	77	52	26.4	38.0	3.5	6	M10
205	195	217	255	237.5	249.6	210	109.2	84.2	77	52	26.4	38.0	3.5	8	M10
210	200	222	260	242.5	254.6	215	109.2	84.2	77	52	26.4	38.0	3.5	8	M10
220	210	232	270	252.5	264.6	225	109.2	84.2	77	52	26.4	38.0	3.5	8	M10
230	220	242	280	262.5	274.6	235	109.2	84.2	77	52	26.4	38.0	3.5	8	M10
240	230	252	290	272.5	284.6	245	109.2	84.2	77	52	26.4	38.0	3.5	8	M10
250	240	262	300	282.5	294.6	255	109.2	84.2	77	52	26.4	38.0	3.5	8	M10
260	250	272	310	292.5	304.6	265	109.2	84.2	77	52	26.4	38.0	3.5	8	M10
270	260	282	320	302.5	314.6	275	109.2	84.2	77	52	26.4	38.0	3.5	8	M10
280	270	292	330	312.5	324.6	285	109.2	84.2	77	52	26.4	38.0	3.5	8	M10
290	280	302	340	322.5	334.6	295	109.2	84.2	77	52	26.4	38.0	3.5	8	M10
300	290	312	350	332.5	344.6	305	109.2	84.2	77	52	26.4	38.0	3.5	8	M10
310	300	322	360	342.5	354.6	315	109.2	84.2	77	52	26.4	38.0	3.5	8	M10

d<sub>1</sub> > 310 on request

inch size available from size 2.000 to 12.250

Note: Additional technical & dimensional information will be provided on request.

The specifications, drawings, images etc included in this catalogue are intended to be generic and must be interpreted as equivalent or functionally equivalent, more specifically the performance capabilities mentioned in this catalogue is based on optimum values, however the performance of the product is dependent on size, material of construction, media, pressure, temperature, sliding velocity etc and it shall vary from size to size or application to application. Customers are requested to consult with Sealmatic before employing the product from this catalogue for any application.



**Product Description**

1. Designed to accommodate axial shaft movement
2. Capable of running dry
3. Radially cut multi-part seal rings
4. Shaft free of sealing components which minimizes the shaft vibrations
5. Seal rings are self adjusting
6. Shaft movement is accommodated by seal rings
7. Minimal power consumption as seal rings are non-contacting
8. Design of the seal housing is split
9. Low leakage due to extremely reduced gap during operation

**Technical Features**

1. Ease of installation during assembly due to split design (dismantling of shaft is not necessary)
2. Operational durability
3. Easy to maintain
4. Trouble free replacement due to segmented seal ring design

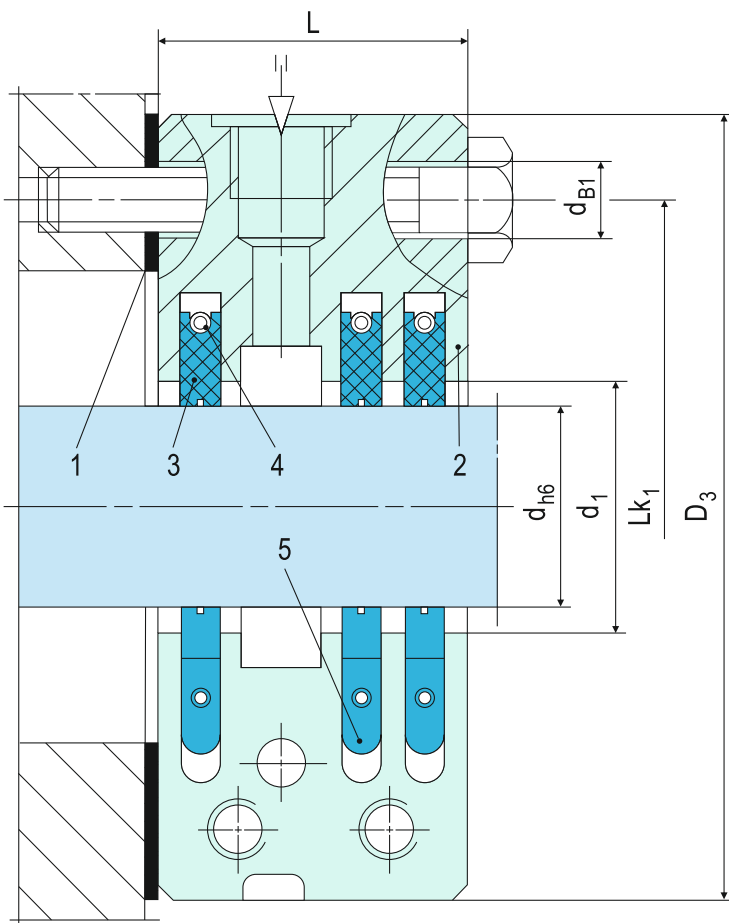

**Note:** The item numbers as depicted above are based on our technical experience and knowledge and are placed in the chronological order of their assembly procedure.

Item	Description
1	Flat seal
2	Housing, 2-piece
3	Seal ring
4	Tension spring
5	Detent

**Typical Industrial Applications**

- Bearing seals (gear box, motors)
- Chemical industry
- Food processing industry
- Fumes and exhaust, solids containing, flammable (ATEX), acid containing and toxic gases (Solids containing) steams / liquid mist Gases
- Medium-sized and large fans / blowers
- Metal production and processing
- Mixers, agitators, mills, dryer
- Oil mist / penetrating oil
- Petrochemical industry
- Power plant technology
- Steam turbines
- Waste incineration and removal industry
- Water

**Standards**

FDA

**Materials**

Seal ring: Carbon, PTFE compound  
 Housing: 1.4021, 1.4571, Hastelloy®, Titanium, Inconel®, others  
 Tension spring / detent: 1.4571, Hastelloy®, Titanium, Inconel®

**Performance Capabilities**

Shaft diameter:  
 $d = 40 \dots 340 \text{ mm} (1.57" \dots 13.39")$   
 Operating pressure:  $p = \text{vacuum} \dots 20 \text{ bar} (290 \text{ PSI}) \text{ abs.}$   
 Operating temperature:  $t = -120 \text{ }^\circ\text{C} \dots +800 \text{ }^\circ\text{C} (-184 \text{ }^\circ\text{F} \dots +1,472 \text{ }^\circ\text{F})$  for carbon, max.  $225 \text{ }^\circ\text{C} (437 \text{ }^\circ\text{F})$  for PTFE compound  
 Speed = max.  $150 \text{ m/s} (492 \text{ ft/s})$  for carbon, max.  $40 \text{ m/s} (131 \text{ ft/s})$  for PTFE compound  
 Radial play:  $\pm 1.0 \dots 5.0 \text{ mm} (\pm 0.04" \dots 0.2")$   
 Axial movement: theoretically unlimited  
 Recommended wear guard:  $>300 \text{ HB}$  (low pressure),  $>58 \text{ HRC}$  (high pressure)



ADKS 200 (split design)



Seal rings ADKS 200 (3-part, radial cut),  
Carbon / PTFE compound

Product Variants

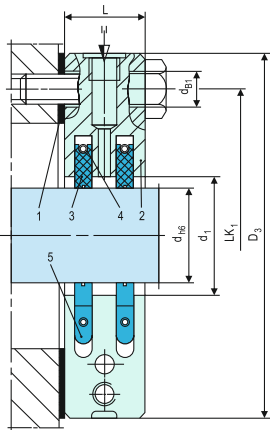

**ADKF**

With short design, reduced housing outside diameter and grease barrier port (for clean media, not for solids containing gases).

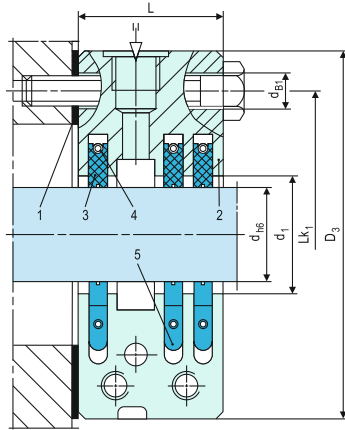

**ADKS 200**

For toxic and solids containing gases as well as ATEX applications type shaft seal with short design, reduced housing outside diameter and barrier gas port (for e.g. toxic and solids containing gases).

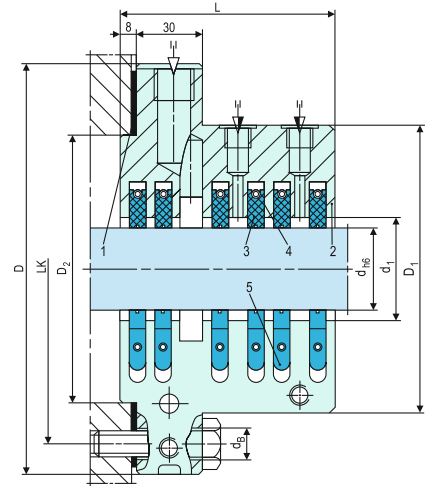

**ADS**

With barrier gas and grease barrier port (for e.g. toxic and solids containing gases as well as ATEX applications, on special request).

The specifications, drawings, images etc included in this catalogue are intended to be generic and must be interpreted as equivalent or functionally equivalent, more specifically the performance capabilities mentioned in this catalogue is based on optimum values, however the performance of the product is dependent on size, material of construction, media, pressure, temperature, sliding velocity etc and it shall vary from size to size or application to application. Customers are requested to consult with Sealmatic before employing the product from this catalogue for any application.



### Product Description

1. Single seal configuration
2. Balanced design
3. Independent of direction of rotation
4. Semi-Cartridge construction
5. No dynamic O-ring on the shaft

### Technical Features

1. O-rings are dynamically loaded to prevent shaft damage
2. Easy and trouble-free installation
3. Due to large radial clearance the damage to the seal faces are avoided, in addition to the seal faces being protected by strong steel parts
4. Misalignment during installation and operations is reduced due to the static springs

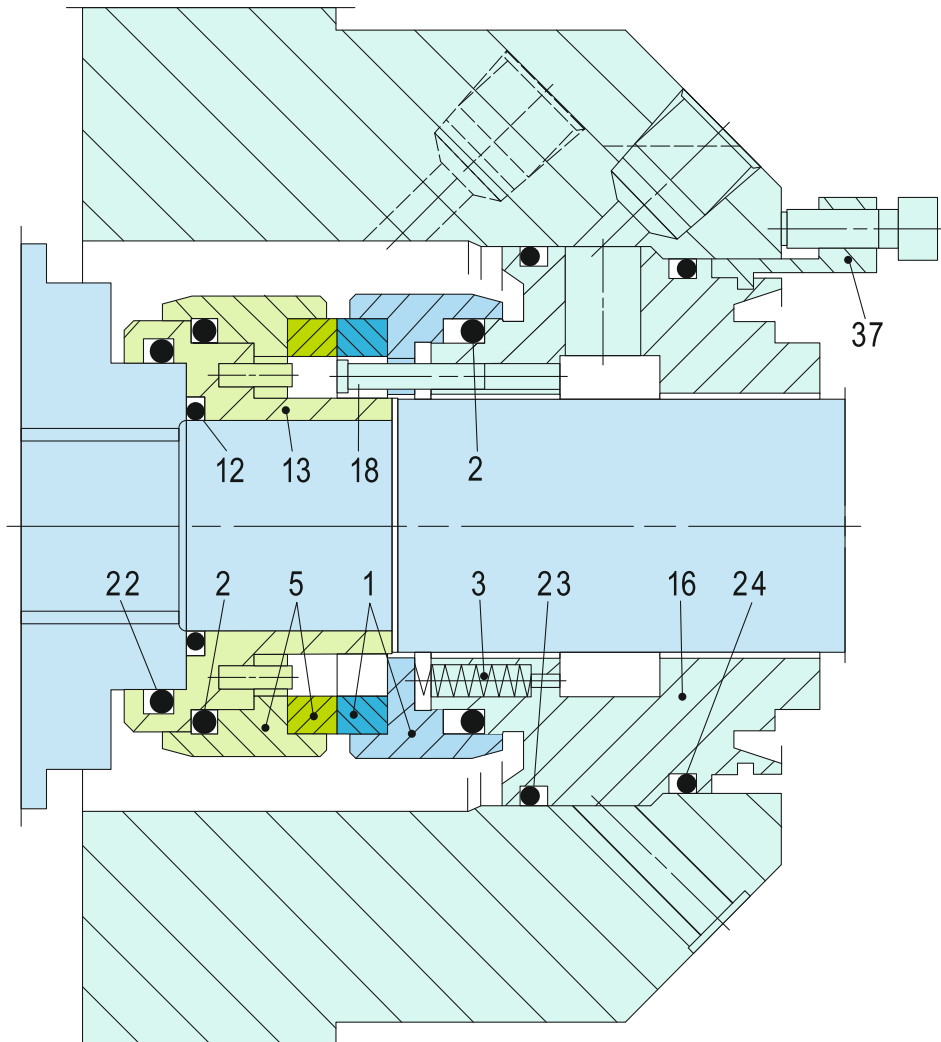

### Typical Industrial Applications

Pulp and paper industry  
 Chemical industry  
 All clean non abrasive media

### Performance Capabilities

Temperature:  $t = -20\text{ }^{\circ}\text{C} \dots +140\text{ }^{\circ}\text{C}$   
 ( $-4\text{ }^{\circ}\text{F} \dots +284\text{ }^{\circ}\text{F}$ )  
 Pressure:  $p_1 \dots 25\text{ bar (363 PSI)}$   
 Sliding velocity:  $v_g \dots 20\text{ m/s (66 ft/s)}$

### Materials

Seal face: Silicon carbide (Q12), Carbon (A)  
 Secondary seals: FKM (V), EPDM (E), FFKM (K)  
 Metal parts: CrNiMo steel (G), Grade 5A (4T), SMO 654 (4U)

### Suitable for following equipments

Ahlstar UP A MS21 range of pumps  
 Sulzer A, APP/APT pumps  
 Sulzer SL mixers  
 Metso conical refiners  
 Stock pumps

Item	Description
1,5	Seal face
2, 12, 22, 23, 24	O-ring
3	Spring
13	Sleeve
16	Housing
18	Pin
37	Assembly fixture

The specifications, drawings, images etc included in this catalogue are intended to be generic and must be interpreted as equivalent or functionally equivalent, more specifically the performance capabilities mentioned in this catalogue is based on optimum values, however the performance of the product is dependent on size, material of construction, media, pressure, temperature, sliding velocity etc and it shall vary from size to size or application to application. Customers are requested to consult with Sealmatic before employing the product from this catalogue for any application.



### Product Description

1. Dual seal configuration
2. Balanced design
3. Independent of direction of rotation
4. Semi-Cartridge construction
5. Double pressure balanced design
6. Designed with provision for internal barrier fluid circulation
7. No dynamic O-ring on the shaft
8. Robust construction with shrink-fitted seal faces
9. Seal faces have a large clearance to the shaft
10. Static springs on both the sides

### Technical Features

1. Seals can be operated with pressurized barrier fluid or with quench
2. O-rings are dynamically loaded to prevent shaft damage
3. Easy and trouble-free installation
4. Due to large radial clearance, the damage to the seal faces are avoided, in addition to the seal faces being protected by strong steel parts
5. Misalignment during installation and operations is reduced due to the static springs on both the faces
6. Dual seal can also be used as a single seal by removing the atmospheric seal parts

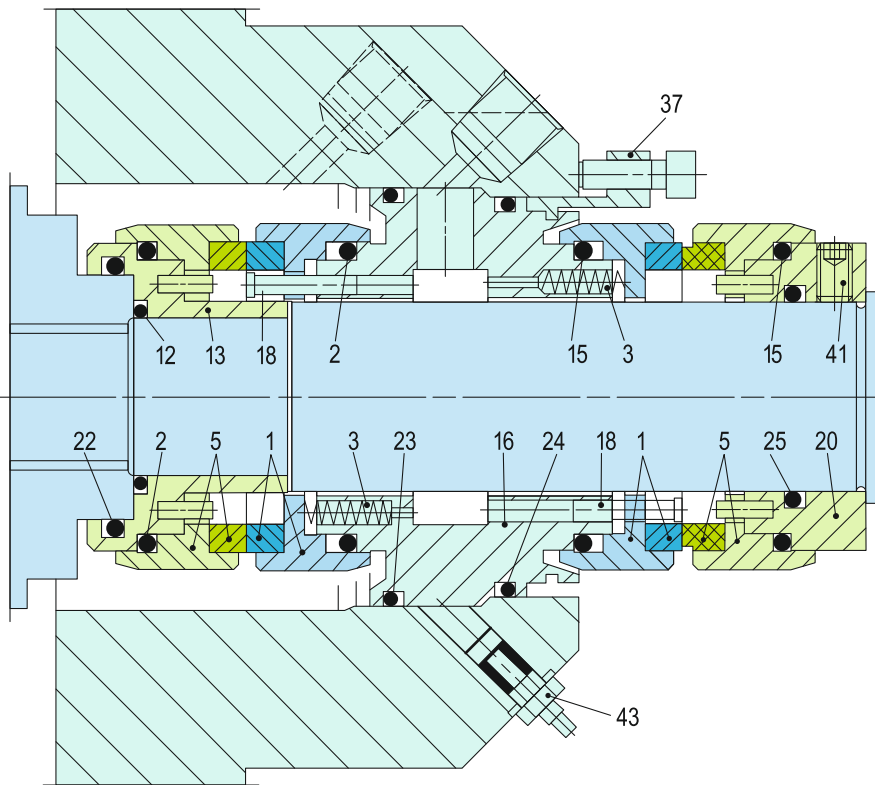

Item	Description
1	Seal face
5	Seat
13	Sleeve
16	Housing
18	Pin
37	Assembly fixture
2, 12, 15, 22, 23, 24, 25	O-ring
43	Plug

### Typical Industrial Applications

Pulp and paper industry  
 Chemical industry  
 Clean, abrasive or corrosive liquids  
 Stocks of various kind  
 Applications where crystallization is a problem

### Performance Capabilities

Temperature:  $t = -20\text{ °C} \dots +140\text{ °C}$   
 ( $-4\text{ °F} \dots +284\text{ °F}$ )  
 (180 °C (356 °F) with FFKM elastomers)  
 Pressure:  $p_1 \dots 25\text{ bar}$  (363 PSI),  $p_3$   
 Speed = 20 m/s (66 ft/s)

Non-flow operation:  
 Temperature:  $t = +5\text{ °C} \dots +100\text{ °C}$   
 ( $+41\text{ °F} \dots +212\text{ °F}$ )  
 Pressure:  $p_1$  max. 10 bar (145 PSI),  $p_3 > p_1$   
 Sliding velocity:  $v_g \dots 20\text{ m/s}$  (66 ft/s)

### Materials

Seal face: Silicon carbide (Q12), Carbon (A)  
 Secondary seals: FKM (V), EPDM (E), FFKM (K)  
 Metal parts: CrNiMo steel (G), Grade 5A (4T), SMO 654 (4U)

### Suitable for following equipments

Ahlstar UP A MS21 range of pumps  
 Sulzer A, APP/APT pumps  
 Sulzer SL mixers  
 Metso conical refiners  
 Stock pumps

The specifications, drawings, images etc included in this catalogue are intended to be generic and must be interpreted as equivalent or functionally equivalent, more specifically the performance capabilities mentioned in this catalogue is based on optimum values, however the performance of the product is dependent on size, material of construction, media, pressure, temperature, sliding velocity etc and it shall vary from size to size or application to application. Customers are requested to consult with Sealmatic before employing the product from this catalogue for any application.



### Product Description

1. Single and Dual seal configuration
2. Balanced design
3. Independent of direction of rotation
4. Cartridge construction
5. Stationary design with multiple springs
6. Seat arrangement is designed behind the impeller
7. Seat design is rotary
8. Specially designed sleeve to protect the springs from contamination
9. Variable designs available with guide sleeve for applications with or without quench

### Technical Features

1. Accommodates shaft deflections due to stationary design
2. Designed to handle media containing solids
3. O-ring is dynamically loaded to prevent shaft damage.
4. Can operate under vacuum without locking the seat
5. Pumping device available for increased efficiency in circulation
6. Springs are product protected to avoid contamination

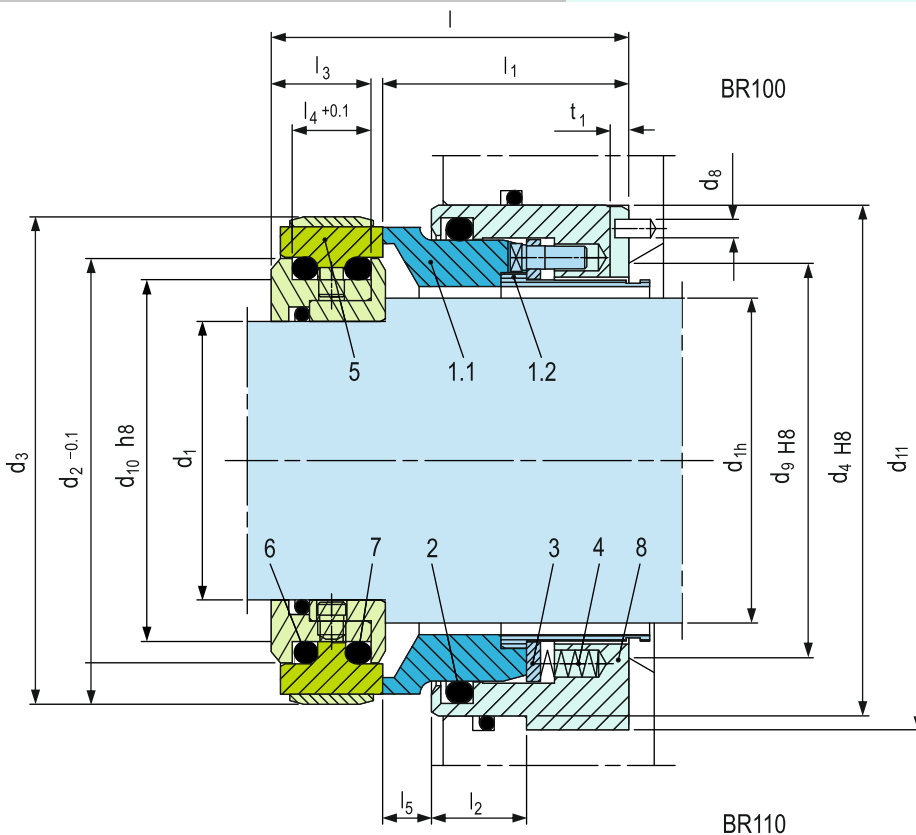

**Note:** The item numbers as depicted above are based on our technical experience and knowledge and are placed in the chronological order of their assembly procedure.

Item	Part no.	Description
1.1	472	Seal face
1.2	520	Sleeve
2	412.1	O-ring
3	474	Thrust ring
4	477	Spring
5	475	Seat (G11)
6	412.2	O-ring
7	412.3	O-ring
8	441	Housing

**DIN 24250**

**Direction of installation:-** from the impeller side BR100 from the bearing side BR110

### Typical Industrial Applications

Water and waste water technology  
 Dirty, abrasive and solids containing media  
 Dredger pumps  
 Mining industry  
 Oil and gas industry  
 Oil sand extraction plants  
 Power plant technology  
 Pulp and paper industry  
 Sewage water pumps  
 Scrubbers in FGD plants

### Performance Capabilities

Sizes:  $d_N$  = Upto 270 mm (Upto 10.625")  
 Pressure:  $p_1$  (\*) = 16 bar (230 PSI)  
 Temperature:  $t$  = -20 °C ...+ 160 °C  
 (-4 °F ...+ 320 °F)  
 Speed = 10 m/s (33 ft/s)  
 \*) For operation under vacuum it is necessary to arrange for quenching on the atmosphere side.

### Standards

EN 12756

### Materials

Seal face: Silicon carbide (Q1, Q2)  
 Seat: Silicon carbide (Q1, Q2)

### Notes

Direction of installation:  
 From the impeller side: BR100  
 From the bearing side: BR110

### Stationary Seats

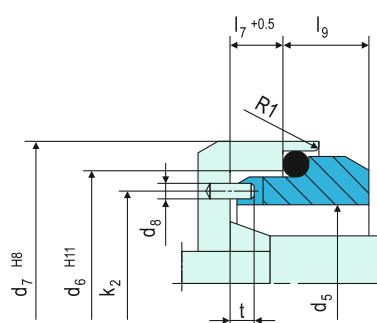

**G2**  
( $d_N$  36 ... 90 mm)

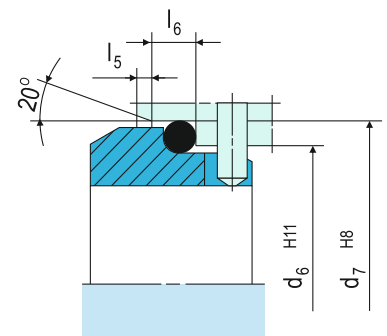

**G9**  
( $d_N$  95 ... 180 mm)

## Design Variations

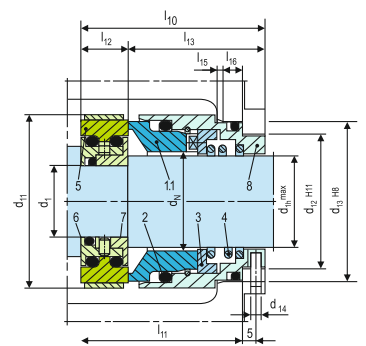
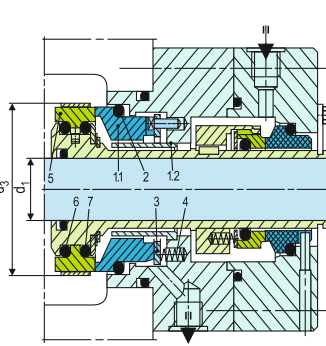
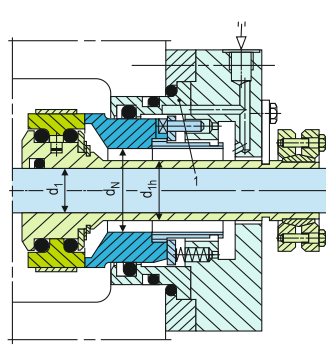
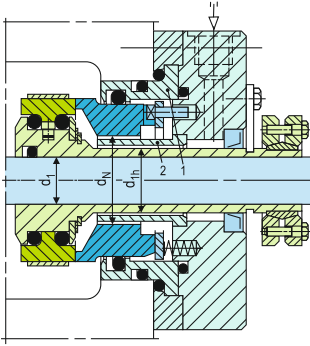

### BR200

Cartridge-type single seal with guide sleeve (Item no. 2) for use with quench. Insert (Item no. 1) either metal or silicon carbide.

### BR300

Cartridge-type single seal. Insert (Item no. 1) either metal or silicon carbide. Optional without maintenance rinsing.

### BRKS-D

Double seal in cartridge design for operation in barrier or buffer pressure (does not open if barrier pressure fails), available alternatively with a pumping screw for a higher rate of circulation. Torque transmission e.g. by shrink disk.

### BRZ100

Single seal with cylindrical spring and type G76 seat. For installation in covers with installation dimensions according to EN 12756 B or U. Installation length  $l_{11}$  corresponds to max.  $l_{1k}$ . Intermediate sizes on request.

## Dimensional Data

### Dimensions in millimeter

$d_1$	$d_{1h}$	$d_N$	$d_2$	$d_3$	$d_4$	$d_5$	$d_6$	$d_7$	$d_8$	$d_9$	$d_{10}$	$d_{11}$ +0.2min	$l$	$l_1$	$l_2$	$l_3$	$l_4$	$l_5$	$l_6$	$l_7$	$l_9$	$k_2$	$t$	$t_1$
20	28	36	47.1	65	70	46	56	63	4	40	38	75	75	53	20	19.5	17	10.5	6	9	8	51	4.5	3
25	33	41	52.1	70	75	51	62	70	4	45	43	80	75	53	20	19.5	17	10.5	6	9	9.5	56.5	4.5	3
28	38	46	57.1	75	80	56	67	75	4	50	48	85	75	53	20	19.5	17	10.5	6	9	9.5	61.5	4.5	3
33	43	51	62.1	80	85	61	72	80	4	55	53	90	75	53	20	19.5	17	10.5	6	9	10.5	66.5	4.5	3
38	48	56	67.1	85	90	66	77	85	4	60	58	95	75	53	20	19.5	17	10.5	6	9	10.5	71.5	4.5	3
43	53	61	72.1	90	95	69	81	90	4	65	63	100	75	53	20	19.5	17	10.5	7	9	11	75	4.5	3
48	58	66	77.1	95	100	76	88	97	4	70	68	105	75	53	20	19.5	17	10.5	7	9	11.5	82	4.5	3
53	63	71	82.1	101	105	81	95	105	4	75	73	110	75	53	20	19.5	17	10.5	7	9	11.5	88	4.5	3
55	65	75	87.1	106	110	86	100	110	4	79	78	115	75	53	20	19.5	17	10.5	7	9	11.5	93	4.5	3
60	70	80	92.1	111	115	91	105	115	4	84	83	120	75	53	20	19.5	17	10.5	7	9	13	98	4.5	3
65	75	85	97.1	116	120	96	110	120	4	89	88	125	75	53	20	19.5	17	10.5	7	9	13	103	4.5	3
70	80	90	102.1	121	125	101	115	125	4	94	93	130	75	53	20	19.5	17	10.5	7	9	13	108	4.5	3
75	85	95	107.1	126	130	107	122.2	134.3	5	99	98	135	75	53	20	19.5	17	10.5	10	12	20	114.5	7	3
80	90	100	112.1	131	135	107	122.2	134.3	5	104	103	140	75	53	20	19.5	17	10.5	10	12	20	114.5	7	3
90	100	110	126.1	147	155	117	136.2	148.3	5	116	117	163	98	73	30	22	19	16.0	10	12	20	126.5	7	4
100	110	120	136.1	157	165	132	146.2	158.3	5	126	127	173	98	73	30	22	19	16.0	10	12	20	139	7	4
110	120	130	145.1	167	175	142	156.2	168.3	5	136	136	183	98	73	30	22	19	16.0	10	12	20	149	7	4
120	130	140	154.1	177	185	152	168.2	180.3	5	146	145	193	98	73	30	22	19	16.0	10	12	22	160	7	4
130	140	150	163.9	188	195	162	178.2	190.3	5	156	155	203	98	73	30	22	19	16.0	12	12	24	170	7	4
140	150	160	174.9	189	205	172	188.2	200.3	5	166	166	213	98	73	30	22	19	16.0	12	12	24	180	7	4
160	170	180	193.9	220	230	187	212.5	224.3	5	186	185	238	98	73	30	22	19	16.0	12	12	28	199.5	7	4
180	190	200	213.9	240	255	-	-	-	-	206	205	265	98	73	30	22	19	16.0	-	-	-	-	-	4
190	200	210	231.9	255	270	-	-	-	-	218	220	280	115	83	40	28.35	24.7	19.0	-	-	-	-	-	5
200	210	220	241.9	265	280	-	-	-	-	228	230	290	115	83	40	28.35	24.7	19.0	-	-	-	-	-	5
210	220	230	251.9	275	290	-	-	-	-	238	240	300	115	83	40	28.35	24.7	19.0	-	-	-	-	-	5
220	230	240	261.9	285	300	-	-	-	-	248	250	310	115	83	40	28.35	24.7	19.0	-	-	-	-	-	5
230	240	250	271.9	295	310	-	-	-	-	258	260	320	115	83	40	28.35	24.7	19.0	-	-	-	-	-	5
250	260	270	291.9	315	330	-	-	-	-	278	280	340	115	83	40	28.35	24.7	19.0	-	-	-	-	-	5

### BRZ100 Dimensional Data

#### Dimensions in millimeter

$d_N$	$d_{1h}$	$d_1$	$d_{11}$	$d_{12}$	$d_{13}$	$d_{14}$	$l_{10}$	$l_{11}$	$l_{12}$	$l_{13}$	$l_{15}$	$l_{16}$
35	33	20	56	42	48	3	57.7	49.2	15	42.7	2	5
43	39	27	67	54	61	4	57.7	49.2	15	42.7	2	6
54	50	35	78	65	73	4	59.8	52.1	15.5	44.3	2.5	6
66	60	47	91	77	85	4	66	58	16.5	49.5	2.5	6
77	72	55	103	88	97	4	74.5	66	17.5	57	2.5	7
100	90	70	125	110	120	4	82	73	21	61	3	7

Dimensions for shaft diameters from 250 mm on request.

inch size available from size 0.750 to 10.625

Note: Additional technical & dimensional information will be provided on request.

The specifications, drawings, images etc included in this catalogue are intended to be generic and must be interpreted as equivalent or functionally equivalent, more specifically the performance capabilities mentioned in this catalogue is based on optimum values, however the performance of the product is dependent on size, material of construction, media, pressure, temperature, sliding velocity etc and it shall vary from size to size or application to application. Customers are requested to consult with Sealmatic before employing the product from this catalogue for any application.



### Product Description

1. Single seal configuration
2. Balanced design
3. Independent of direction of rotation
4. Cartridge construction
5. Stationary design with multiple springs
6. Designed with integrated pumping device for increased efficiency in circulation
7. Robust construction with shrink-fitted seal face
8. Heavy duty design of solid stationary seat

### Technical Features

1. Accommodates shaft deflections due to stationary design
2. Can be designed for individual pump application with corresponding connection parts to be adopted to the pump seal chamber
3. Optimum heat dissipation due to integrated pumping device available for increased efficiency in circulation and optimized seat design
4. Cartridge unit factory assembled for easy installation, which reduces down-time
5. Trouble-free long-term operation due to heavy duty single seat design with bandage
6. Can operate under high sliding velocities and high pressures

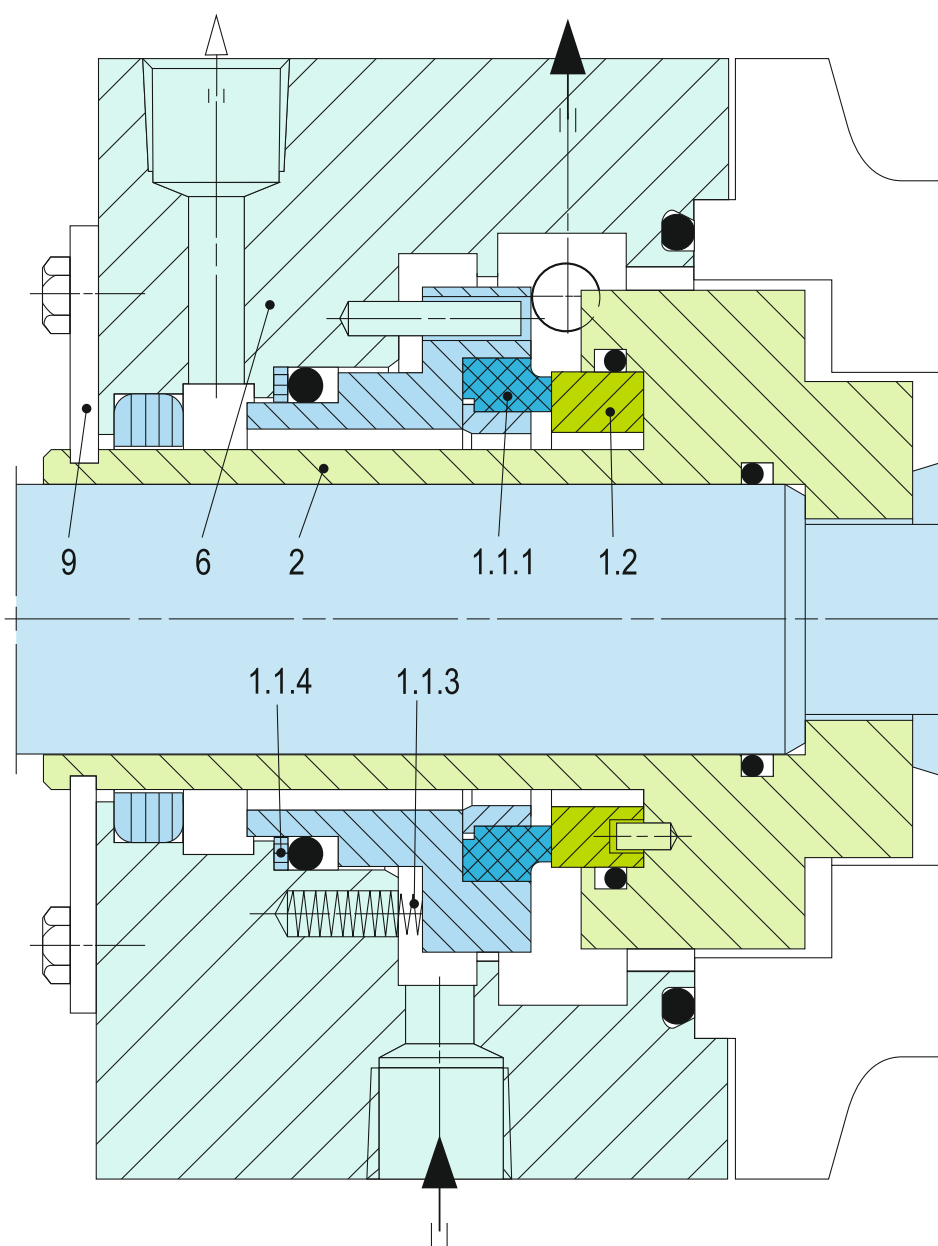

### Typical Industrial Applications

Amines	Injection pumps
Caustic soda	Multi-phase pumps
Chemical industry	Oil and gas industry
Crude oil	Process water
Crystallizing media	Refining technology
Crude oil feed pumps	Sour water
Hot water	

### Standards

API 682 / ISO 21049

### Performance Capabilities

Sizes:  $d_1^*$  = Upto 250 mm (Upto 10.000")  
 Pressure:  $p_1$  = 150 bar (2,175 PSI)  
 Temperature:  $t$  = 300 °C (572 °F)  
 Speed = 60 m/s (197 ft/s)  
 Permissible axial movement:  $\pm$  3 mm  
 \* Other sizes on request

### Materials

Seal face: SiC-C-Si Silicon impregnated carbon (Q3), Carbon graphite antimony impregnated (A)  
 Seat: Silicon carbide (Q)  
 Secondary seals: FKM (V), EPDM (E), FFKM (K)  
 Springs: Hastelloy® C-4 (M)  
 Metal parts: CrNiMo steel (G), Duplex (G1), Super Duplex (G4), Titanium (T2), Hastelloy® C-4 (M)

### Design Variations

#### SBFV

Same design as SBPV but with pumping screw

Item	Description
1.1.1	Seal face pressure-stabilized
1.1.3	Spring
1.1.4	Back-up ring
1.2	Seat
2	Seat housing with pumping screw (F) or pumping ring (P)
6	Cover
9	Assembly fixture

The specifications, drawings, images etc included in this catalogue are intended to be generic and must be interpreted as equivalent or functionally equivalent, more specifically the performance capabilities mentioned in this catalogue is based on optimum values, however the performance of the product is dependent on size, material of construction, media, pressure, temperature, sliding velocity etc and it shall vary from size to size or application to application. Customers are requested to consult with Sealmatic before employing the product from this catalogue for any application.





### Product Description

1. Dual seal configuration
2. Balanced design
3. Independent of direction of rotation
4. Cartridge construction
5. Stationary design with multiple springs
6. Designed with integrated pumping device for increased efficiency in circulation
7. Robust construction with shrink-fitted seal face
8. Heavy duty design of solid stationary seat

### Technical Features

1. Accommodates shaft deflections due to stationary design
2. Can be designed for individual pump application with corresponding connection parts to be adopted to the pump seal chamber
3. Optimum heat dissipation due to integrated pumping device available for increased efficiency in circulation and optimized seat design
4. Cartridge unit factory assembled for easy installation, which reduces down-time
5. Trouble-free long-term operation due to heavy duty single seat design with bandage
6. Can operate under high sliding velocities and high pressures
7. Can be adopted for use in compliance with API 682, type ES
8. Versatile application for various kinds of heavy duty applications

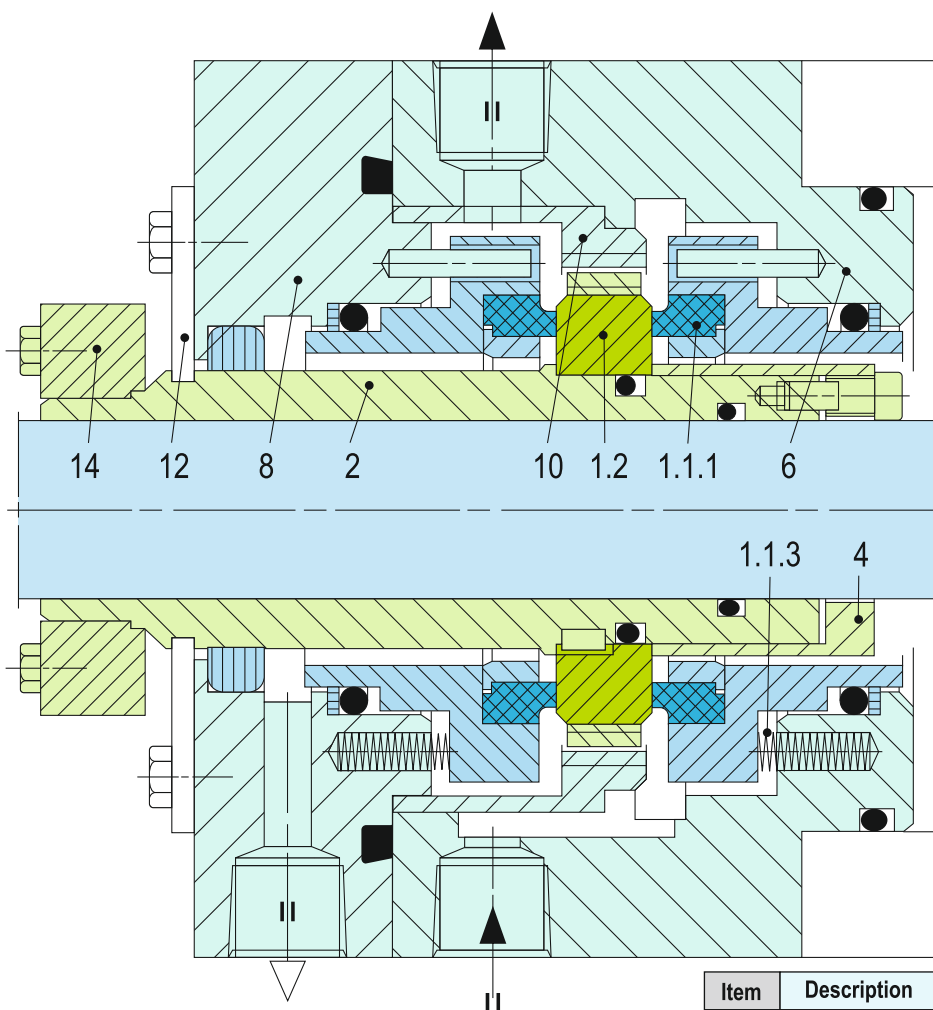

Item	Description
1.1.1	Seal face
1.1.3	Spring
1.2	Seat
2	Shaft sleeve
4	Clamping sleeve
6	Housing
8	Cover
10	Pumping sleeve
12	Assembly fixture
14	Shrink disk

### Typical Industrial Applications

Chemical industry  
 Crude oil  
 Crude oil feed pumps  
 Injection pumps  
 Multi-phase pumps  
 Oil and gas industry  
 Process water  
 Refining technology  
 Volatile and non-volatile hydrocarbons

### Standards

API 682 / ISO 21049

### Performance Capabilities

Sizes:  $d_1^*$  = Upto 250 mm (Upto 10.000")  
 Pressure:  $p_1$  = 150 bar (2,175 PSI)  
 Temperature:  $t$  = 200 °C (392 °F)  
 Speed = 60 m/s (197 ft/s)  
 \* Other sizes on request

### Materials

Seal face: SiC-C-Si, Silicon impregnated carbon (Q3), Carbon graphite antimony impregnated (A)  
 Seat: Silicon carbide (Q)  
 Secondary seals: FKM (V), EPDM (E), FFKM (K)  
 Springs: Hastelloy® C-4 (M)  
 Metal parts: CrNiMo steel (G), Duplex (G1), Super Duplex (G4), Pure Titanium (T2), Hastelloy® C-4 (M)

### Design Variations

#### SBF(V)1-D / SBP(V)1-D

Same design as SBF(V)-D / SBP(V)-D but with loosely inserted seal face for extreme applications.  
 Pressure:  $p_1$  = 200 bar (2900 PSI)

The specifications, drawings, images etc included in this catalogue are intended to be generic and must be interpreted as equivalent or functionally equivalent, more specifically the performance capabilities mentioned in this catalogue is based on optimum values, however the performance of the product is dependent on size, material of construction, media, pressure, temperature, sliding velocity etc and it shall vary from size to size or application to application. Customers are requested to consult with Sealmatic before employing the product from this catalogue for any application.



### Product Description

1. Single seal configuration
2. Balanced design
3. Independent of direction of rotation
4. Cartridge construction
5. Stationary design with multiple springs
6. Designed with integrated pumping device for increased efficiency in circulation
7. Robust construction with shrink-fitted seal seat
8. Heavy duty design of solid stationary seat

### Technical Features

1. Accommodates shaft deflections due to stationary design
2. Can be designed for individual pump application with corresponding connection parts to be adapted to the pump seal chamber
3. Optimum heat dissipation due to integrated pumping device available for increased efficiency in circulation and optimized seat design
4. Cartridge unit factory assembled for easy installation, which reduces downtime
5. Trouble-free long-term operation due to heavy duty single seat design with bandage
6. Can operate under high sliding velocities and medium pressures

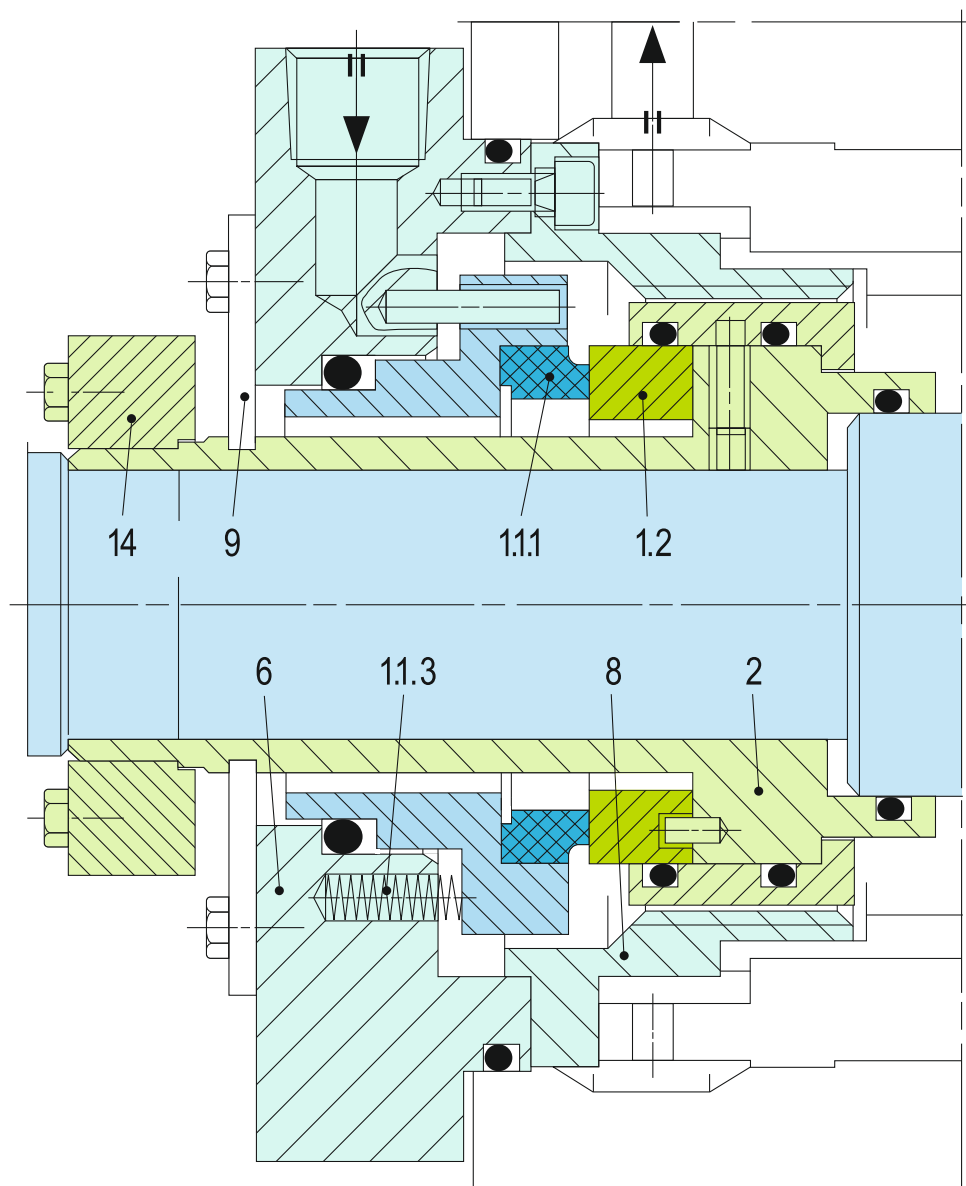

### Typical Industrial Applications

Boiler feed water pumps  
Power plant technology

### Performance Capabilities

Sizes:  $d_1^*$  = Upto 250 mm (Upto 10.000")  
Pressure:  $p_1$  = 50 bar (725 PSI)  
Temperature:  $t$  = 300 °C (572 °F)  
Speed = 60 m/s (197 ft/s)  
Permissible axial movement:  $\pm 3$  mm  
\* Other sizes on request

### Materials

Seal face: Silicon carbide (Q), Carbon graphite antimony impregnated (A), Carbon graphite resin impregnated (B)  
Seat: Silicon carbide  
Secondary seals: EPDM (E), FFKM (K)  
Springs: CrNiMo steel (G)  
Metal parts: CrNiMo steel (G)

### Design Variations

#### SBF400

Single Mechanical Seal with integrated jacket cooling, for boiler feed pumps

Item	Description
1.1.1	Seal face
1.1.3	Spring
1.2	Seat
2	Shaft sleeve
6	Cover
8	Pumping screw with flow guide
9	Assembly fixture
14	Shrink disk

The specifications, drawings, images etc included in this catalogue are intended to be generic and must be interpreted as equivalent or functionally equivalent, more specifically the performance capabilities mentioned in this catalogue is based on optimum values, however the performance of the product is dependent on size, material of construction, media, pressure, temperature, sliding velocity etc and it shall vary from size to size or application to application. Customers are requested to consult with Sealmatic before employing the product from this catalogue for any application.

# B100 / B800 Single Seals

# Standard Mechanical Seals - Pusher Seals



## Product Description

1. Single seal configuration
2. Balanced design
3. Independent of direction of rotation
4. Stationary design with multiple springs

## Technical Features

1. Compact design
2. Capable of withstanding high pressure
3. O-ring is dynamically loaded to prevent shaft damage.
4. Spring loaded stationary design accommodates shaft misalignments
5. Can handle media with solid content
6. Easy to assemble due to short axial installation length

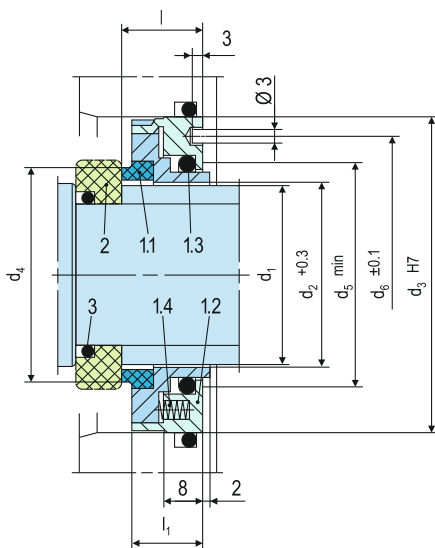

Note: The item numbers as depicted above are based on our technical experience and knowledge and are placed in the chronological order of their assembly procedure.

Item	Part no.	Description
1.1	472	Seal face
	473	Seal face housing
1.2	485	Drive collar
1.3		O-ring
1.4	477	Spring
2	475	Rotating seat <sup>1)</sup>
3	412.2	O-ring

DIN 24250

<sup>1)</sup> The seat design is chosen according to the specific requirements and conditions of operation.

## Typical Industrial Applications

All seal chambers with a very short axial installation length  
 Bearing seal  
 Lube oils  
 Process industry  
 Roller seal

## Performance Capabilities

Sizes:  $d_1$  = Upto 100 mm (Upto 4.000")  
 Pressure:  $p_1$  = 25 bar (363 PSI)  
 Temperature:  $t$  = -40 °C...+180 °C  
 (-40 °F...+356 °F)  
 Speed = 50 m/s (164 ft/s)

## Materials

Seal face: Carbon graphite antimony impregnated (A), Carbon graphite resin impregnated (B)

## Dimensional Data

Dimensions in millimeter

$d_1$	$d_2$	$d_2'$	$d_3$	$d_4$	$d_5$	$d_6$	$l$	$l_1$	$l_1'$
15	16	17	42	22.6	21	34	17	15.0	16
18	19	-	45	25.6	24	37	17	15.0	-
20	21	22	48	27.6	26	40	17	15.0	16
22	23	24	50	29.6	28	42	17	15.0	16
25	26	27	52	32.8	31	44	17	15.0	16
28	29	-	55	35.8	34	47	17	15.0	-
30	31	32	58	37.8	36	50	17	15.0	16
32	33	34	60	39.8	38	52	17	15.0	16
35	36	37	62	42.8	41	54	17	15.0	16
38	39	40	65	45.9	44	57	17	15.0	16
40	41	42	68	47.9	46	60	17	15.0	16
42	43	44	72	49.9	48	64	17	15.0	16
45	46	47	75	52.9	51	67	17	15.0	16
48	49	-	80	55.9	54	72	17	15.0	-
50	51	52	80	58.2	56	72	17	15.0	16
52	53	-	82	60.2	58	74	17	15.0	-
55	56	57	85	63.2	61	77	17	15.0	16
58	59	-	90	66.7	64	82	17	15.0	-
60	61	62	90	68.7	66	82	17	15.0	16
65	66	67	95	73.7	71	87	19	16.5	18
68	69	70	100	76.7	74	92	19	16.5	18
70	71	72	100	78.7	76	92	19	16.5	18
75	76	77	108	83.7	81	100	19	16.5	18
80	81	82	112	88.7	86	104	19	16.5	18
85	86	87	118	93.7	91	110	19	16.5	18
90	91	92	122	99.5	96	114	19	16.5	18
95	96	97	128	104.5	101	120	19	16.5	18
100	101	102	132	109.5	106	124	19	16.5	18

inch size available from size 0.750 to 4.000

Note: Additional technical & dimensional information will be provided on request.

The specifications, drawings, images etc included in this catalogue are intended to be generic and must be interpreted as equivalent or functionally equivalent, more specifically the performance capabilities mentioned in this catalogue is based on optimum values, however the performance of the product is dependent on size, material of construction, media, pressure, temperature, sliding velocity etc and it shall vary from size to size or application to application. Customers are requested to consult with Sealmatic before employing the product from this catalogue for any application.

## Design Variations

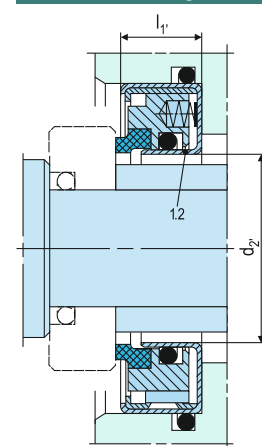

**B800**  
 Dimensions, items and description as B100. Drive collars and housings for item 1.2 are made of deepdrawn stainless steel sheet.

**B100Z**  
 Dimensions, items & descriptions as per B100, but with Wave spring instead of multiple springs



### Product Description

1. Single seal configuration
2. Balanced design
3. Independent of direction of rotation
4. For plain shafts
5. Stationary design with multiple springs

### Technical Features

1. Accommodates shaft deflections due to stationary design
2. Designed to handle media containing solids
3. O-ring is dynamically loaded to prevent shaft damage.
4. Can operate under vacuum without locking the seat
5. Pumping device available for increased efficiency in circulation
6. Springs are product protected to avoid contamination
7. Compact installation design
8. Can accommodate reverse pressure

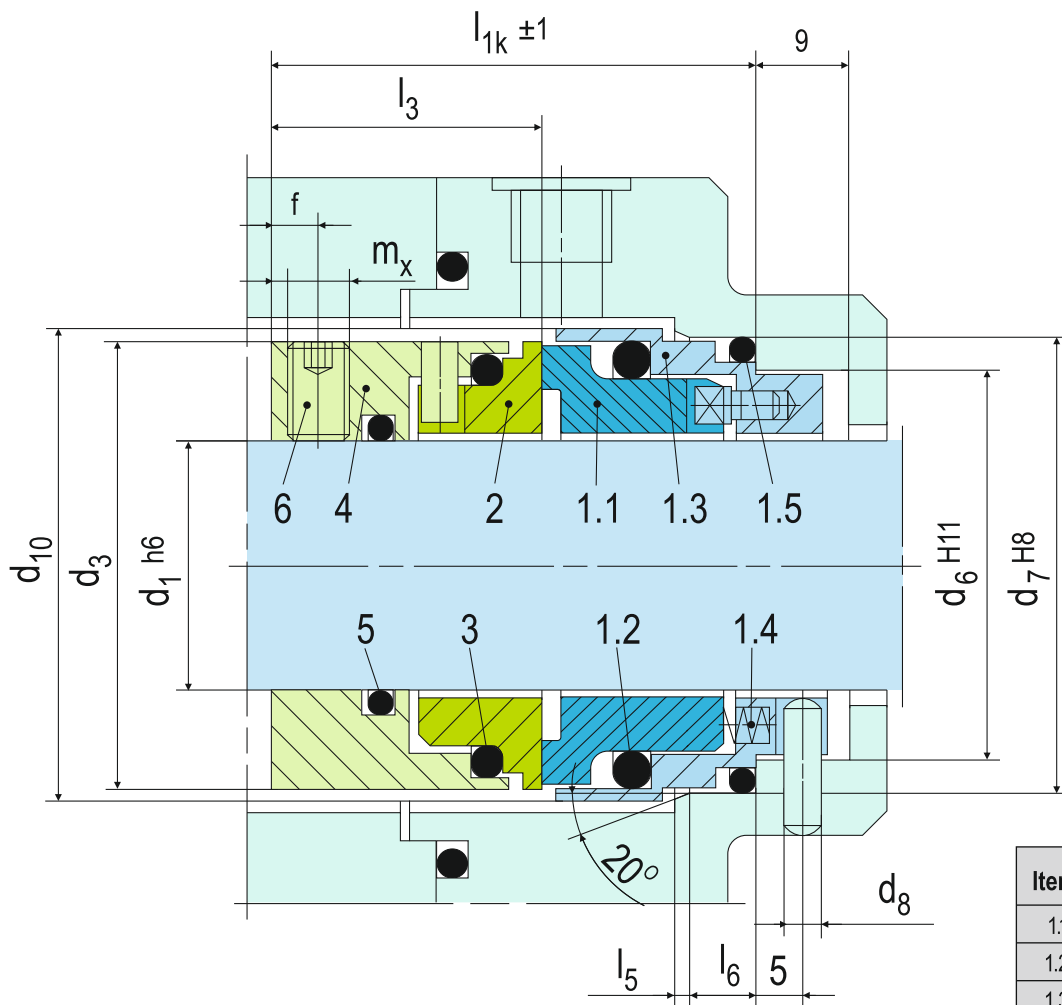

**Note:** The item numbers as depicted above are based on our technical experience and knowledge and are placed in the chronological order of their assembly procedure.

Item	Part no.	Description
1.1	472	Seal face
1.2	412.1	O-ring
1.3	485	Retainer
1.4	477	Spring
1.5	412.2	O-ring
2	475	Seat
3	412.3	O-ring
4	485	Drive collar
5	412.4	O-ring
6	904	Set screw

DIN 24250

### Typical Industrial Applications

Chemical industry  
 Dirty, abrasive and solid containing media  
 Fugitive hydrocarbons  
 Refining technology  
 Sticky and stringy media  
 Water and waste water technology  
 Chemical standard pumps  
 Sewage pumps

### Performance Capabilities

Sizes:  $d_1 =$  Upto 100 mm (Upto 4.000")  
 Pressure:  $p_1^*) = 25$  bar (363 PSI)  
 Temperature:  $t = -40$  °C .. +220 °C  
 (-40 °F .. + 428 °F)  
 Speed = 20 m/s (66 ft/s)  
 Permissible axial movement:  $\pm 1.0$  mm  
 \*) Additional seat locking is not needed in vacuum operation. For operation under vacuum it is necessary to arrange for quenching on the atmosphere.

### Materials

Seal face: Carbon graphite resin impregnated (B), Silicon carbide (Q1)  
 Seat: Silicon carbide (Q1)  
 Secondary seals: FKM (V), NBR (P), FFKM (K), PTFE (T)  
 Springs: Hastelloy® C-4 (M)  
 Metal parts: CrNiMo steel (G)

### Standards

EN 12756

### Dimensional Data

Dimensions in millimeter

$d_1$	$d_3$	$d_6$	$d_7$	$d_8$	$d_{10}$	$l_{1k}$	$l_3$	$l_5$	$l_6$	$f$	$m_x$
18	33	27	33	3	34.7	37.5	19.5	2.0	5	3.0	4
20	35	29	35	3	36.7	37.5	19.5	2.0	5	3.0	4
22	37	31	37	3	38.7	37.5	19.5	2.0	5	3.0	4
24	39	33	39	3	40.7	40.0	20.5	2.0	5	3.5	5
25	40	34	40	3	41.7	40.0	20.5	2.0	5	3.5	5
28	43	37	43	3	44.7	42.5	21.5	2.0	5	3.5	5
30	45	39	45	3	46.7	42.5	21.5	2.0	5	3.5	5
32	48	42	48	3	49.7	42.5	21.5	2.0	5	3.5	5
33	48	42	48	3	49.7	42.5	21.5	2.0	5	3.5	5
35	50	44	50	3	51.7	42.5	21.5	2.0	5	3.5	5
38	56	49	56	4	57.7	45.0	24.0	2.0	6	4.0	6
40	58	51	58	4	59.7	45.0	24.0	2.0	6	4.0	6
43	61	54	61	4	62.7	45.0	24.0	2.0	6	4.0	6
45	63	56	63	4	64.7	45.0	24.0	2.0	6	4.0	6
48	66	59	66	4	67.7	45.0	24.0	2.0	6	4.0	6
50	70	62	70	4	71.7	47.5	25.0	2.5	6	4.0	6
53	73	65	73	4	74.7	47.5	25.0	2.5	6	4.0	6
55	75	67	75	4	76.7	47.5	25.0	2.5	6	4.0	6
58	78	70	78	4	80.5	52.5	28.0	2.5	6	4.0	6
60	80	72	80	4	82.5	52.5	28.0	2.5	6	4.0	6
63	83	75	83	4	85.5	52.5	28.0	2.5	6	4.0	6
65	85	77	85	4	87.5	52.5	28.0	2.5	6	4.0	6
68	90	81	90	4	92.5	52.5	28.0	2.5	7	4.0	6
70	92	83	92	4	94.5	60.0	34.0	2.5	7	6.0	8
75	97	88	97	4	100.5	60.0	34.0	2.5	7	6.0	8
80	105	95	105	4	108.5	60.0	34.0	3.0	7	6.0	8
85	110	100	110	4	113.5	60.0	34.0	3.0	7	6.0	8
90	115	105	115	4	118.5	65.0	39.0	3.0	7	10.0	8
95	120	110	120	4	123.5	65.0	39.0	3.0	7	10.0	8
100	125	115	125	4	128.5	65.0	39.0	3.0	7	10.0	8

inch size available from size 0.750 to 4.000

Note: Additional technical & dimensional information will be provided on request.

The specifications, drawings, images etc included in this catalogue are intended to be generic and must be interpreted as equivalent or functionally equivalent, more specifically the performance capabilities mentioned in this catalogue is based on optimum values, however the performance of the product is dependent on size, material of construction, media, pressure, temperature, sliding velocity etc and it shall vary from size to size or application to application. Customers are requested to consult with Sealmatic before employing the product from this catalogue for any application.



### Product Description

1. Single seal configuration
2. Balanced design
3. Independent of direction of rotation
4. For plain shafts
5. Rotary unit with encapsulated spring design

### Technical Features

1. Compact design with rugged construction
2. Capable of withstanding high pressure
3. O-ring is dynamically loaded to prevent shaft damage.
4. Can handle media with solid content and viscous media
5. Can handle sterile and vacuum application
6. Springs are product protected to avoid contamination

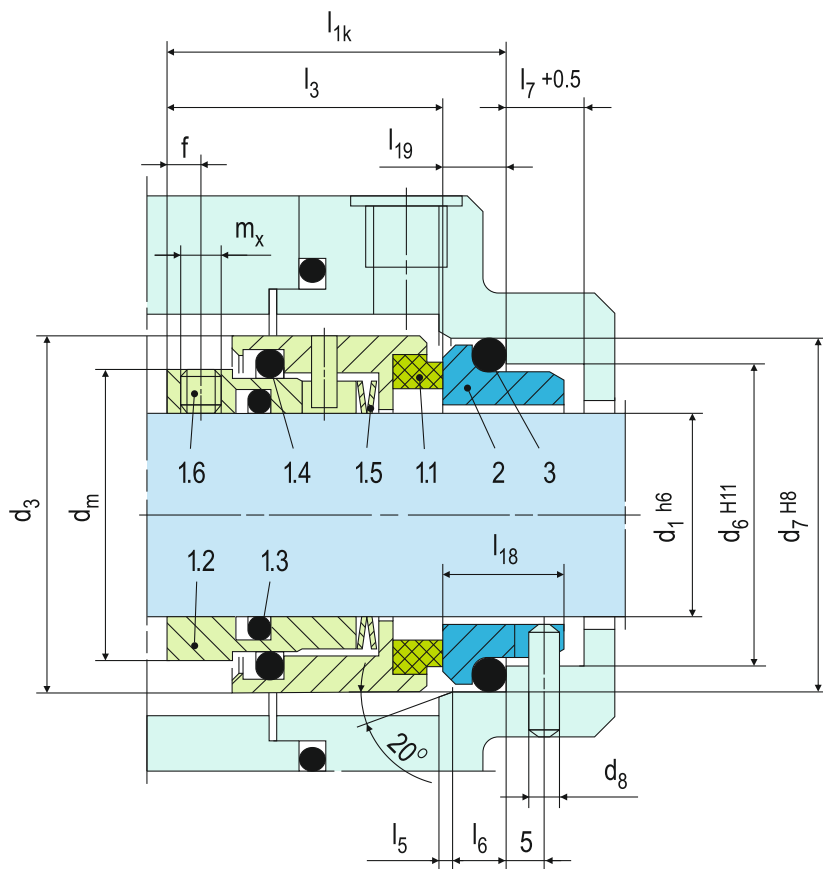

**Note:** The item numbers as depicted above are based on our technical experience and knowledge and are placed in the chronological order of their assembly procedure.

Item	Part no.	Description
1.1	472/473	Seal face
1.2	485	Drive collar
1.3	412.2	O-ring
1.4	412.1	O-ring
1.5	477	Spring
1.6	904	Set screw
2	475	Seat (G16)
3	412.3	O-ring

**DIN 24250**

### Typical Industrial Applications

Conveying and bottling of dairy products  
 Dirty, abrasive and solids containing media  
 Pulp and paper industry  
 Sugar industry  
 Water and waste water technology  
 Raw sludge pumps  
 Raw sludge, sewage slurries  
 Thick juice pumps

### Performance Capabilities

Sizes:  $d_1$  = Upto 100 mm (Upto 4.000")  
 Pressure:  $p_1^{(1)}$  = 0.8 abs... 25 bar  
 (12 abs.... 363 PSI)  
 Temperature:  $t$  = -50 °C...+ 220 °C  
 (-58 °F...+ 430 °F)  
 Speed = 20 m/s (66 ft/s)  
 Permissible axial movement:  $\pm 0.5$  mm  
<sup>1</sup> An integral stationary seat lock is not needed within the permissible low pressure range. For prolonged operation under vacuum it is necessary to arrange for quenching on the atmospheric side.

### Standards

EN 12756

### Notes

Variant for sterile applications available.  
 Please enquire.

### Materials

Seal face: Carbon graphite antimony impregnated (A),  
 Carbon graphite resin impregnated (B)  
 Seat G16: Silicon carbide (Q1)

## Design Variations

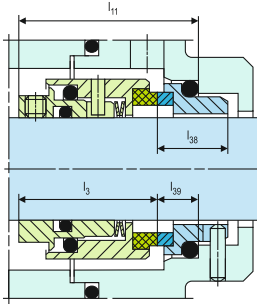

### BJ927GN

Items and description as BJ920N.  
 Seal face: Carbon graphite antimony impregnated (A), Carbon graphite resin impregnated (B)  
 Seat G46: Silicon carbide (Q12)  
 1) Installation length  $l_{11} (= l_3 + l_{38})$  is longer than  $l_{1k}$ .

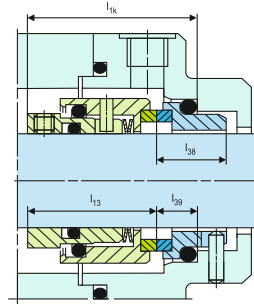

### BJ977GN

Items and description as BJ920N.  
 Seal face: Silicon carbide (Q12)  
 Seat G46: Silicon carbide (Q12)  
 Installation length  $l_{1k}$   
 Operating range:  
 Temperature:  $t = -20\text{ °C} \dots +180\text{ °C}$   
 ( $-4\text{ °F} \dots +356\text{ °F}$ )  
 Speed = 10 m/s (33 ft/s)

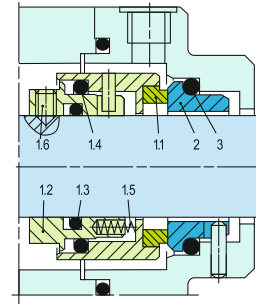

### BJ470

Mechanical seals with product-protected multiple springs, for high pressure applications.  
 Pressure:  $p = \text{max. } 50\text{ bar (725 PSI)}$   
 Shaft diameter:  $d_1 > \text{Upto } 100\text{ mm (Upto } 4.000\text{")}$ .  
 Smaller diameters and higher pressures on request.

### BJ970GN

Items and description as BJ920N.  
 Seal face: Silicon carbide (Q12)  
 Seat G16: Silicon carbide (Q1)  
 2) Installation length  $l_{12} (= l_{13} + l_{39})$  is shorter than  $l_{1k}$ .

## Dimensional Data

### Dimensions in millimeter

$d_1$	$d_3$	$d_6$	$d_7$	$d_8$	$d_m$	$l_{1k}$	$l_3$	$l_5$	$l_6$	$l_7$	$l_{18}$	$l_{19}$	$l_{11}^{1)}$	$l_{12}^{2)}$	$l_{13}$	$l_{38}$	$l_{39}$	$f$	$m_x$
18	32	27	33	3	26.0	37.5	30.5	2.0	5	9	15.0	7.0	39.5	35.5	28.5	17.0	9.0	3.0	M4
20	34	29	35	3	28.0	37.5	30.5	2.0	5	9	15.0	7.0	39.5	35.5	28.5	17.0	9.0	3.0	M4
22	36	31	37	3	30.0	37.5	30.5	2.0	5	9	15.0	7.0	39.5	35.5	28.5	17.0	9.0	3.0	M4
24	38	33	39	3	32.5	40.0	33.0	2.0	5	9	15.0	7.0	42.0	38.0	31.0	17.0	9.0	3.5	M5
25	39	34	40	3	33.5	40.0	33.0	2.0	5	9	15.0	7.0	42.0	38.0	31.0	17.0	9.0	3.5	M5
28	42	37	43	3	36.5	42.5	35.5	2.0	5	9	15.0	7.0	45.0	40.0	33.0	17.5	9.5	3.5	M5
30	44	39	45	3	38.5	42.5	35.5	2.0	5	9	15.0	7.0	45.0	40.0	33.0	17.5	9.5	3.5	M5
32	47	42	48	3	41.5	42.5	35.5	2.0	5	9	15.0	7.0	45.0	40.0	33.0	17.5	9.5	3.5	M5
33	47	42	48	3	41.5	42.5	35.5	2.0	5	9	15.0	7.0	45.0	40.0	33.0	17.5	9.5	3.5	M5
35	49	44	50	3	43.5	42.5	35.5	2.0	5	9	15.0	7.0	45.0	40.0	33.0	17.5	9.5	3.5	M5
38	54	49	56	4	47.5	45.0	37.0	2.0	6	9	16.0	8.0	47.5	42.5	34.5	18.5	10.5	4.0	M5
40	56	51	58	4	49.5	45.0	37.0	2.0	6	9	16.0	8.0	47.5	42.5	34.5	18.5	10.5	4.0	M5
43	59	54	61	4	52.5	45.0	37.0	2.0	6	9	16.0	8.0	47.5	42.5	34.5	18.5	10.5	4.0	M5
45	61	56	63	4	54.5	45.0	37.0	2.0	6	9	16.0	8.0	47.5	42.5	34.5	18.5	10.5	4.0	M5
48	64	59	66	4	57.5	45.0	37.0	2.0	6	9	16.0	8.0	47.5	42.5	34.5	18.5	10.5	4.0	M5
50	66	62	70	4	59.5	47.5	38.0	2.5	6	9	17.0	9.5	50.0	45.0	35.5	19.5	12.0	4.5	M6
53	69	65	73	4	62.5	47.5	38.0	2.5	6	9	17.0	9.5	50.0	45.0	35.5	19.5	12.0	4.5	M6
55	71	67	75	4	64.5	47.5	38.0	2.5	6	9	17.0	9.5	50.0	45.0	35.5	19.5	12.0	4.5	M6
58	78	70	78	4	68.5	52.5	42.0	2.5	6	9	18.0	10.5	55.0	50.0	39.5	20.5	13.0	4.5	M6
60	80	72	80	4	70.5	52.5	42.0	2.5	6	9	18.0	10.5	55.0	50.0	39.5	20.5	13.0	4.5	M6
63	83	75	83	4	73.5	52.5	42.0	2.5	6	9	18.0	10.5	55.0	50.0	39.5	20.5	13.0	4.5	M6
65	85	77	85	4	75.5	52.5	42.0	2.5	6	9	18.0	10.5	55.0	50.0	39.5	20.5	13.0	4.5	M6
68	88	81	90	4	78.5	52.5	41.5	2.5	7	9	18.5	11.0	55.0	50.0	39.0	21.0	13.5	4.5	M6
70	90	83	92	4	80.5	60.0	48.5	2.5	7	9	19.0	11.5	62.5	57.5	46.0	21.5	14.0	5.0	M6
75	99	88	97	4	89.0	60.0	48.5	2.5	7	9	19.0	11.5	62.5	57.5	46.0	21.5	14.0	5.5	M8
80	104	95	105	4	94.0	60.0	48.5	3.0	7	9	19.0	11.5	62.5	57.5	46.0	21.5	14.0	5.5	M8
85	109	100	110	4	99.0	60.0	48.5	3.0	7	9	19.0	11.5	62.5	57.5	46.0	21.5	14.0	5.5	M8
90	114	105	115	4	104.0	65.0	52.0	3.0	7	9	20.5	13.0	67.5	62.5	49.5	23.0	15.5	5.5	M8
95	119	110	120	4	109.0	65.0	52.0	3.0	7	9	20.5	13.0	67.5	62.5	49.5	23.0	15.5	5.5	M8
100	124	115	125	4	114.0	65.0	52.0	3.0	7	9	20.5	13.0	67.5	62.5	49.5	23.0	15.5	5.5	M8

inch size available from size 0.750 to 4.000

Note: Additional technical & dimensional information will be provided on request.

The specifications, drawings, images etc included in this catalogue are intended to be generic and must be interpreted as equivalent or functionally equivalent, more specifically the performance capabilities mentioned in this catalogue is based on optimum values, however the performance of the product is dependent on size, material of construction, media, pressure, temperature, sliding velocity etc and it shall vary from size to size or application to application. Customers are requested to consult with Sealmatic before employing the product from this catalogue for any application.



### Product Description

1. Single seal configuration
2. Balanced design
3. Independent of direction of rotation
4. For stepped shafts
5. Multiple or wave springs rotary construction
6. Pumping device available for increased efficiency in circulation (B700F, B750F)
7. High temperature application with cooled stationary seats available

### Technical Features

1. Versatile torque transmission available
2. Capable of self cleaning
3. Short installation length available on request
4. Multifaceted application usage

### Typical Industrial Applications

Boiler feed pumps  
 Hot water applications  
 Light hydrocarbons  
 Oil and gas industry  
 Petrochemical industry  
 Power plant technology  
 Process pumps  
 Refining technology

### Materials

Seal face: Silicon carbide (Q1, Q2), Carbon graphite antimony impregnated (A), Aluminium oxide (V), CrMo cast steel (S)  
 Seat G9: Carbon graphite antimony impregnated (A), Carbon graphite resin impregnated (B), Silicon carbide (Q1\*, Q2\*)  
 Secondary seals: EPDM (E), NBR (P), FKM (V), FFKM (K)  
 Springs: CrNiMo steel (G)  
 Metal parts: CrNiMo steel (G), Duplex (G1)  
 \* Cannot be combined with seal face made of S

### Standards

EN 12756

### Performance Capabilities

Sizes:  $d_1 =$  Upto 100 mm (Upto 4.000")  
 (Single spring:  $d_1 =$  max. Upto 100 mm (Upto 4.000"))  
 Pressure:  
 $p_1 = 80$  bar (1160 PSI) for  $d_1 = 14 \dots 100$  mm,  
 $p_1 = 25$  bar (363 PSI) for  $d_1 = 100 \dots 200$  mm,  
 $p_1 = 16$  bar (232 PSI) for  $d_1 > 200$  mm  
 Temperature:  $t = -50 \text{ }^\circ\text{C} \dots +220 \text{ }^\circ\text{C}$   
 (-58  $^\circ\text{F} \dots +428 \text{ }^\circ\text{F}$ )  
 Speed = 20 m/s (66 ft/s)  
 Permissible axial movement:  
 $d_1$  up to 22 mm:  $\pm 1.0$  mm  
 $d_1$  24 up to 58 mm:  $\pm 1.5$  mm  
 $d_1$  from 60 mm:  $\pm 2.0$  mm

### Torque Transmissions

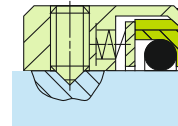

$d_1 > 100$  mm (4.000")  
 Torque transmission by 4 set screws with cone point. Offset: 90°

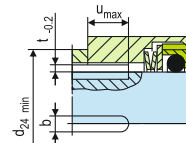

Drive key  
 (B700S2 / B750S2)

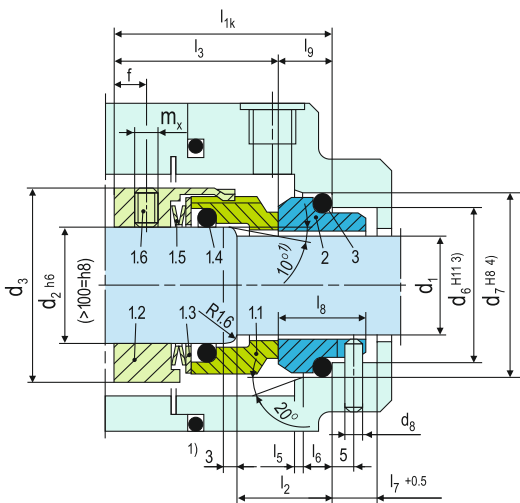

Note: The item numbers as depicted above are based on our technical experience and knowledge and are placed in the chronological order of their assembly procedure.

Item	Part no.	Description
1.1	472	Seal face
1.2	485	Drive collar
1.3	474	Thrust ring
1.4	412.1	O-ring
1.5	477	Spring
1.6	904	Set screw
2	475	Seat (G9)
3	412.2	O-ring

**DIN 24250**

1) $d_1 > 100$ mm: 2 mm x 30°
2) $d_1 > 100$ mm: 30°
3) $d_1 > 100$ mm: +0.1
4) $d_1 > 100$ mm: H7

### Stationary Seats

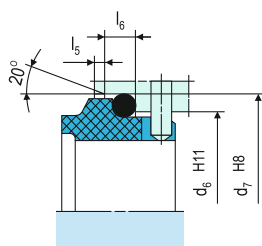

**G9**  
 (EN 12756)

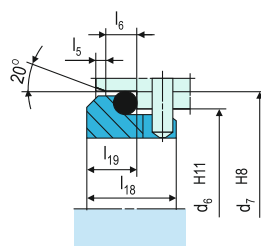

**G16**  
 (EN 12756, but  $l_{1k}$  and  $l_2$  are shorter than specified)

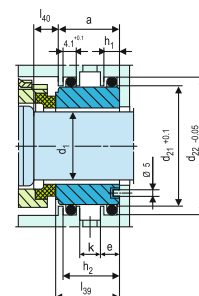

**G115**  
 Cooled seat especially for hot water applications.



## Design Variations

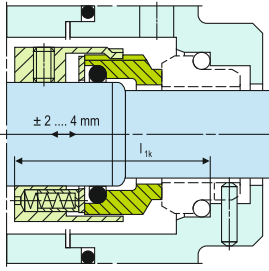

### B750

Shaft diameter:  $d_1 =$  Upto 200 mm (Upto 7.875")  
As B700N, but with multiple springs in sleeves (Item no.1.5)  
Axial movement:  $\pm 2 \dots 4$  mm, dependent on diameter

### B751

Dimensions, Items & descriptions as per B750, but with PTFE wedge as secondary sealing

### B752

Dimensions, Items & descriptions as per B750, but with Solid Carbon Seal Face

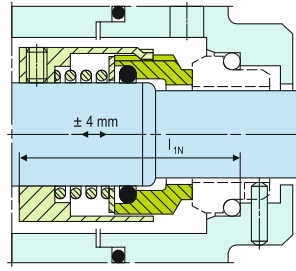

### B760

Shaft diameter:  $d_1 =$  Upto 100mm (Upto 4.000")  
Dimensions, items and description as for B700N, but with special single spring (Item no. 1.5) for compensating large axial movements ( $\pm 4$  mm).

### B752H

Dimensions, Items & descriptions as per B750, but with Solid Carbon Seal Face & Hydraulic Groove on the seal face

### B753

Dimensions, Items & descriptions as per B750, but with Dry running face combination

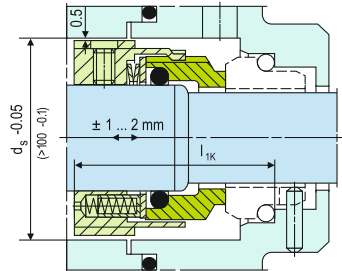

### B700F

Shaft diameter :  $d_1 =$  max. Upto 100mm (Upto 4.000")  
Dimensions, items and descriptions as for B700N, but with single spring and pumping screw.  
Dependent on direction of rotation. (Viscosity  $\leq$  ISO VG10).

### B750F

Shaft diameter:  $d_1 =$  Upto 200 mm (Upto 7.875")  
Dimensions, items and descriptions as for B700N, but with single spring and pumping screw.  
Dependent on direction of rotation. (Viscosity  $\leq$  ISO VG10).

## Dimensional Data

### Dimensions in millimeter

d <sub>1</sub>	d <sub>2</sub>	d <sub>3</sub>	d <sub>6</sub>	d <sub>7</sub>	d <sub>8</sub>	d <sub>24</sub>	d <sub>21</sub>	d <sub>22</sub>	d <sub>8</sub>	l <sub>1K</sub>	l <sub>1N</sub>	l <sub>2</sub>	l <sub>3</sub>	l <sub>5</sub>	l <sub>6</sub>	l <sub>7</sub>	l <sub>8</sub>	l <sub>9</sub>	l <sub>18</sub>	l <sub>19</sub>	l <sub>39</sub>	l <sub>40</sub>	a	b	e	f	h <sub>1</sub>	h <sub>2</sub>	k	m <sub>x</sub>	u <sub>max.</sub>	t		
14*	18	33	21	25	3	20	-	-	38	42.5	-	18	32.5	1.5	4	8.5	17.5	10.0	-	-	-	-	-	5	-	6.0	-	-	-	M5	9	1.1		
16*	20	35	23	27	3	22	-	-	40	42.5	-	18	32.5	1.5	4	8.5	17.5	10.0	-	-	-	-	-	5	-	6.0	-	-	-	M5	9	1.1		
18*	22	37	27	33	3	24	-	-	42	45.0	55	20	33.5	2.0	5	9.0	19.5	11.5	15.0	7.0	-	-	-	6	-	7.0	-	-	-	M5	9	1.5		
20*	24	39	29	35	3	26	-	-	44	45.0	60	20	33.5	2.0	5	9.0	19.5	11.5	15.0	7.0	-	-	-	6	-	5.5	-	-	-	M5	9	1.5		
22*	26	41	31	37	3	28	-	-	45	45.0	60	20	33.5	2.0	5	9.0	19.5	11.5	15.0	7.0	-	-	-	6	-	8.0	-	-	-	M5	9	1.5		
24*	28	43	33	39	3	30	-	-	47	47.5	60	20	36.0	2.0	5	9.0	19.5	11.5	15.0	7.0	-	-	-	6	-	5.5	-	-	-	M6	9	1.5		
25*	30	45	34	40	3	32	-	-	49	47.5	60	20	36.0	2.0	5	9.0	19.5	11.5	15.0	7.0	-	-	-	6	-	5.5	-	-	-	M6	9	1.5		
28*	33	48	37	43	3	35	44.65	50.57	51	50.0	65	20	38.5	2.0	5	9.0	19.5	11.5	15.0	7.0	24.0	8.5	24.0	6	8.0	8.0	6.6	22.6	9	M6	12	1.5		
30*	35	50	39	45	3	37	47.83	53.75	54	50.0	65	20	38.5	2.0	5	9.0	19.5	11.5	15.0	7.0	24.5	9.0	24.0	6	8.0	8.0	6.6	22.6	9	M6	12	1.5		
32*	38	55	42	48	3	40	47.83	53.75	59	50.0	65	20	38.5	2.0	5	9.0	19.5	11.5	15.0	7.0	24.5	9.0	24.0	6	8.0	8.0	6.6	22.6	9	M6	12	1.5		
33*	38	55	42	48	3	40	47.83	53.75	59	50.0	65	20	38.5	2.0	5	9.0	19.5	11.5	15.0	7.0	24.5	9.0	24.0	6	8.0	8.0	6.6	22.6	9	M6	12	1.5		
35*	40	57	44	50	3	42	51.00	56.92	61	50.0	65	20	38.5	2.0	5	9.0	19.5	11.5	15.0	7.0	24.5	9.0	24.0	6	8.0	8.0	6.6	22.6	9	M6	12	1.5		
38*	43	60	49	56	4	45	54.18	60.10	65	52.5	75	23	38.5	2.0	6	9.0	22.0	14.0	16.0	8.0	26.0	11.0	24.0	6	8.0	8.0	6.6	22.6	9	M6	12	1.5		
40*	45	62	51	58	4	47	60.53	66.45	66	52.5	75	23	38.5	2.0	6	9.0	22.0	14.0	16.0	8.0	26.0	11.0	24.0	6	8.0	8.0	6.6	22.6	9	M6	12	1.5		
43*	48	65	54	61	4	50	63.70	69.62	69	52.5	75	23	38.5	2.0	6	9.0	22.0	14.0	16.0	8.0	26.0	11.0	24.0	6	8.0	8.0	6.6	22.6	9	M6	12	1.5		
45*	50	67	56	63	4	52	63.70	69.62	71	52.5	75	23	38.5	2.0	6	9.0	22.0	14.0	16.0	8.0	26.0	11.0	24.0	6	8.0	8.0	6.6	22.6	9	M6	12	1.5		
48*	53	70	59	66	4	55	66.88	72.80	75	52.5	85	23	38.5	2.0	6	9.0	22.0	14.0	16.0	8.0	26.0	11.0	24.0	6	8.0	8.0	6.6	22.6	9	M6	12	1.5		
50*	55	72	62	70	4	57	70.05	75.97	76	57.5	85	25	42.5	2.5	6	9.0	23.0	15.0	17.0	9.5	26.5	12.5	24.0	6	8.0	8.0	6.6	24.6	9	M6	12	1.5		
53*	58	79	65	73	4	60	76.40	82.32	83	57.5	85	25	42.5	2.5	6	9.0	23.0	15.0	17.0	9.5	26.5	12.5	24.0	6	8.0	9.0	6.6	24.6	9	M8	12	1.9		
55*	60	81	67	75	4	62	76.40	82.32	85	57.5	85	25	42.5	2.5	6	9.0	23.0	15.0	17.0	9.5	26.5	12.5	26.0	8	8.0	9.0	6.6	24.6	11	M8	12	1.9		
58*	63	84	70	78	4	65	79.58	85.50	88	62.5	85	25	47.5	2.5	6	9.0	23.0	15.0	18.0	10.5	28.5	12.5	26.0	8	8.0	9.0	6.6	24.6	11	M8	15	1.9		
60*	65	86	72	80	4	67	82.75	88.67	95	62.5	95	25	47.5	2.5	6	9.0	23.0	15.0	18.0	10.5	28.5	12.5	26.0	8	8.0	9.0	6.6	24.6	11	M8	15	1.9		
63*	68	89	75	83	4	70	85.93	91.85	93	62.5	95	25	47.5	2.5	6	9.0	23.0	15.0	18.0	10.5	28.5	12.5	26.0	8	8.0	9.0	6.6	24.6	11	M8	14	1.9		
65*	70	91	77	85	4	72	85.93	91.85	95	62.5	95	25	47.5	2.5	6	9.0	23.0	15.0	18.0	10.5	28.5	12.5	26.0	8	8.0	9.0	6.6	24.6	11	M8	15	1.9		
70*	75	99	83	92	4	77	89.10	95.02	105	70.0	95	28	52.0	2.5	7	9.0	26.0	18.0	19.0	11.5	30.5	14.5	26.0	8	8.0	10.0	6.6	24.6	11	M8	15	1.9		
75*	80	104	88	97	4	82	98.63	104.55	109	70.0	105	28	52.0	2.5	7	9.0	26.0	18.0	19.0	11.5	30.5	14.5	26.0	8	8.0	10.0	6.6	24.6	11	M8	15	1.9		
80*	85	109	95	105	4	87	101.80	107.72	114	70.0	105	28	51.8	3.0	7	9.0	26.2	18.2	19.0	11.5	30.2	14.0	26.0	8	8.0	10.0	6.6	24.6	11	M8	15	1.9		
85*	90	114	100	110	4	92	108.15	114.07	119	75.0	105	28	56.8	3.0	7	9.0	26.2	18.2	19.0	11.5	30.2	14.0	26.0	10	8.0	10.0	6.6	24.6	11	M8	18	2.3		
90*	95	119	105	115	4	97	114.50	120.42	124	75.0	105	28	56.8	3.0	7	9.0	26.2	18.2	20.5	13.0	30.2	14.0	26.0	10	8.0	10.0	6.6	24.6	11	M8	18	2.3		
95*	100	124	110	120	4	102	117.68	123.60	129	75.0	105	28	57.8	3.0	7	9.0	25.2	17.2	20.5	13.0	29.2	14.0	26.0	10	8.0	10.0	6.6	24.6	11	M8	18	2.3		
100*	105	129	115	125	4	107	124.03	129.95	134	75.0	105	28	57.8	3.0	7	9.0	25.2	17.2	20.5	13.0	29.2	14.0	26.0	10	8.0	10.0	6.6	24.6	11	M8	18	2.3		
105*	115	148	122.2	134.3	5	118	128.98	134.90	153	73.0	-	32	53.0	2.0	10	-	30.0	20.0	-	-	-	-	29.2	15.2	26.0	10	8.0	10.0	6.6	24.6	11	M8	18	2.3
110*	120	153	128.2	140.3	5	123	135.30	141.20	158	73.0	-	32	53.0	2.0	10	-	30.0	20.0	-	-	-	-	32.5	14.5	30.0	10	9.5	10.0	6.6	28.6	13	M8	18	2.3
115*	125	158	136.2	148.3	5	128	140.30	146.20	163	73.0	-	32	53.0	2.0	10	-	30.0	20.0	-	-	-	-	32.5	14.5	30.0	10	9.5	10.0	6.6	28.6	13	M8	18	2.3
120*	130	163	138.2	150.3	5	133	145.30	151.20	168	73.0	-	32	53.0	2.0	10	-	30.0	20.0	-	-	-	-	32.5	14.5	30.0	10	9.5	10.0	6.6	28.6	13	M8	18	2.3
125*	135	168	142.2	154.3	5	138	150.30	156.20	173	73.0	-	32	53.0	2.0	10	-	30.0	20.0	-	-	-	-	32.5	14.5	30.0	10	9.5	10.0	6.6	28.6	13	M8	18	2.3
130*	140	173	146.2	158.3	5	143	155.30	161.20	178	73.0	-	32	53.0	2.0	10	-	30.0	20.0	-	-	-	-	32.5	14.5	30.0	10	9.5	10.0	6.6	28.6	13	M8	18	2.3
135*	145	178	152.2	164.3	5	148	160.30	166.20	183	73.0	-	32	53.0	2.0	10	-	30.0	20.0	-	-	-	-	32.5	14.5	30.0	10	9.5	10.0	6.6	28.6	13	M8	18	2.3
140*	150	183	156.2	168.3	5	153	165.30	171.20	188	73.0	-	32	53.0	2.0	10	-	30.0	20.0	-	-	-	-	32.5	14.5	30.0	10	9.5	10.0	6.6	28.6	13	M8	18	2.3
145*	155	191	161.2	173.3	5	158	172.30	178.20	196	83.0	-	34	63.0	2.0	10	-	30.0	20.0	-	-	-	-	34.5	16.5	32.0	12	10.0	12.0	7.1	30.1	14	M8	22	2.1
150*	160	196	168.2	180.3	5	163	177.30	183.20	201	85.0	-	36	63.0																					



### Product Description

1. Dual seal configuration
2. Balanced design
3. Independent of direction of rotation
4. For stepped shafts
5. Rotary unit with multiple springs
6. Pumping device available for increased efficiency in circulation (B740F-D)

### Technical Features

1. Versatile torque transmission available
2. Capable of self cleaning
3. Multifaceted application usage
4. Pumping device to increase efficiency in circulation for media with higher viscosity available
5. Short installation length available
6. Suitable for media with low solids content
7. EN 12756 (For connection dimensions  $d_1$ , up to 100 mm)

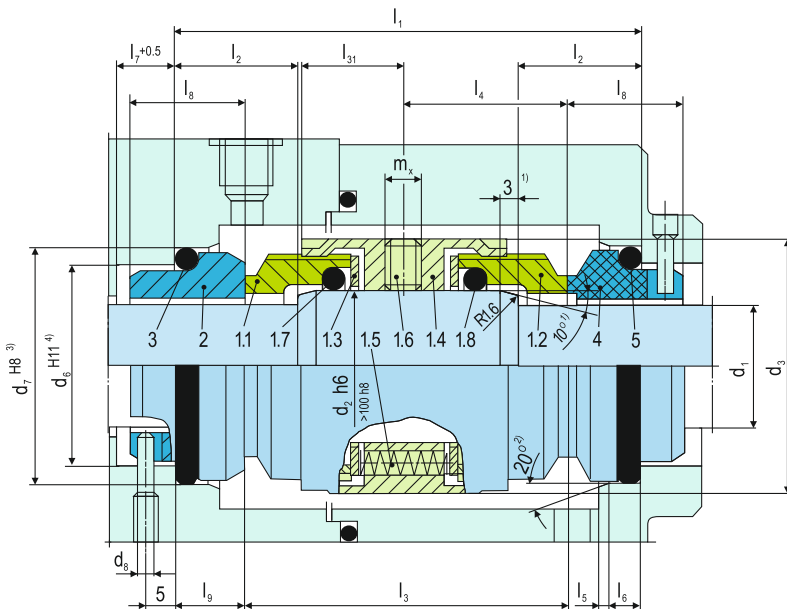

**Note:** The item numbers as depicted above are based on our technical experience and knowledge and are placed in the chronological order of their assembly procedure.

### Typical Industrial Applications

- Adhesives
- Chemical industry
- Media with poor lubrication properties
- Media with low solids content and abrasive particles
- Process industry
- Toxic and hazardous media
- Chemical standard pumps

### Performance Capabilities

- Sizes:  $d_1$  = Upto 200 mm (Upto 7.875")
- Pressure:
  - $p_1 = 80$  bar (1160 PSI) for  $d_1 = 14 \dots 100$  mm,
  - $p_1 = 25$  bar (363 PSI) for  $d_1 = 100 \dots 200$  mm,
  - $p_1 = 16$  bar (232 PSI) for  $d_1 > 200$  mm
- Temperature:  $t = -50 \text{ }^\circ\text{C} \dots +220 \text{ }^\circ\text{C}$  (-58  $^\circ\text{F} \dots +428 \text{ }^\circ\text{F}$ )
- Speed = 20 m/s (66 ft/s)
- Permissible axial movement:
  - $d_1$  up to 100 mm:  $\pm 0.5$  mm
  - $d_1$  from 100 mm:  $\pm 2.0$  mm

### Standards

EN 12756

### Torque Transmission

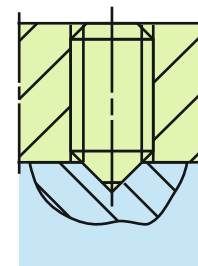

$d_2 \geq 105$  mm VIA 4 set screws with cone points. (standard arrangement)

### Stationary Seats

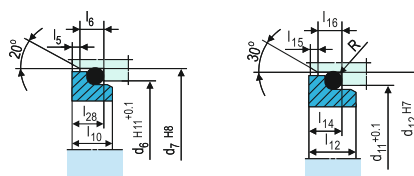

G6 (EN 12756)

G4

Item	Part no.	Description
1.1	472.1	Seal face
1.2	472.2	Seal face
1.3	474	Thrust ring
1.4	485	Drive collar
1.5	477	Spring
1.6	904	Set screw
1.7	412.1	O-ring
1.8	412.2	O-ring
2	475.1	Seat (G9)
3	412.3	O-ring
4	475.2	Seat (G9)
5	412.4	O-ring
<b>DIN 24250</b>		

- <sup>1)</sup>  $d_1 > 100$  mm: 2 mm x 30°
- <sup>2)</sup>  $d_1 > 100$  mm: 30°
- <sup>3)</sup>  $d_1 > 100$  mm: H7
- <sup>4)</sup>  $d_1 > 100$  mm: +0.1

### Materials

Seal face: Silicon carbide (Q1, Q2), Carbon graphite antimony impregnated (A), Aluminium oxide (V), Special cast CrMo steel (S)  
 Seat G9: Carbon graphite antimony impregnated (A), Carbon graphite resin impregnated (B), Silicon carbide (Q1\*, Q2\*)  
 Secondary seals: EPDM (E), NBR (P), FKM (V), FFKM (K)  
 Springs: CrNiMo steel (G)  
 Metal parts: CrNiMo steel (G), Duplex (G1)  
 \* Cannot be combined with seal face made of S

## Design Variations

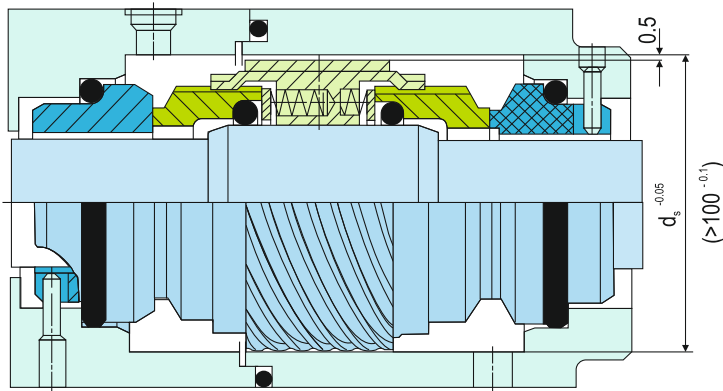

### B740F-D

Dimensions, items and descriptions as for B740-D, but with pumping screw (Item no. 14)  
Dependent on direction of rotation.

## Dimensional Data

### Dimensions in millimeter

d <sub>1</sub>	d <sub>2</sub>	d <sub>3</sub>	d <sub>6</sub>	d <sub>7</sub>	d <sub>8</sub>	d <sub>11</sub>	d <sub>12</sub>	d <sub>s</sub>	l <sub>1</sub>	l <sub>2</sub>	l <sub>3</sub>	l <sub>4</sub>	l <sub>5</sub>	l <sub>6</sub>	l <sub>7</sub>	l <sub>8</sub>	l <sub>9</sub>	l <sub>10</sub>	l <sub>12</sub>	l <sub>14</sub>	l <sub>15</sub>	l <sub>16</sub>	l <sub>28</sub>	l <sub>31</sub>	m <sub>x</sub>	R	
14	18	33	21.0	25	3	20.5	24.6	-	73	18	53	26.5	1.5	4	8.5	17.5	10	7.5	6.5	5.6	1.5	5	6.6	17	M5	1.2	
16	20	35	23.0	27	3	22.0	28.0	-	73	18	53	26.5	1.5	4	8.5	17.5	10	7.5	8.5	7.5	1.5	5	6.6	17	M5	1.5	
18	22	37	27.0	33	3	24.0	30.0	42	76	20	53	26.5	2	5	9	19.5	11.5	8.5	9	8	1.5	5	7.5	17	M5	1.5	
20	24	39	29.0	35	3	29.5	35.0	44	76	20	53	26.5	2	5	9	19.5	11.5	8.5	8.5	7.5	1.5	5	7.5	17	M5	1.5	
22	26	41	31.0	37	3	29.5	35.0	45	76	20	53	26.5	2	5	9	19.5	11.5	8.5	8.5	7.5	1.5	5	7.5	17	M5	1.5	
24	28	43	33.0	39	3	32.0	38.0	47	77	20	54	27	2	5	9	19.5	11.5	8.5	8.5	7.5	1.5	5	7.5	17.5	M6	1.5	
25	30	45	34.0	40	3	32.0	38.0	49	77	20	54	27	2	5	9	19.5	11.5	8.5	8.5	7.5	1.5	5	7.5	17.5	M6	1.5	
28	33	48	37.0	43	3	36.0	42.0	51	77	20	54	27	2	5	9	19.5	11.5	8.5	10	9	1.5	5	7.5	17.5	M6	1.5	
30	35	50	39.0	45	3	39.2	45.0	54	77	20	54	27	2	5	9	19.5	11.5	8.5	11.5	10.5	1.5	5	7.5	17.5	M6	1.5	
32	38	55	42.0	48	3	42.2	48.0	59	79	20	56	28	2	5	9	19.5	11.5	8.5	11.5	10.5	1.5	5	7.5	18.5	M6	1.5	
33	38	55	42.0	48	3	44.2	50.0	59	79	20	56	28	2	5	9	19.5	11.5	8.5	12	10.5	1.5	5	7.5	18.5	M6	1.5	
35	40	57	44.0	50	3	46.2	52.0	61	80	20	57	28.5	2	5	9	19.5	11.5	8.5	12	11	1.5	5	7.5	19	M6	1.5	
38	43	60	49.0	56	4	49.2	55.0	65	85	23	57	28.5	2	6	9	22	14	10	11.3	10.3	2	6	9	19	M6	1.5	
40	45	62	51.0	58	4	52.2	58.0	66	85	23	57	28.5	2	6	9	22	14	10	11.8	10.8	2	6	9	19	M6	1.5	
43	48	65	54.0	61	4	53.3	62.0	69	85	23	57	28.5	2	6	9	22	14	10	13.2	12	2	6	9	19	M6	2.5	
45	50	67	56.0	63	4	55.3	64.0	71	84	23	56	28	2	6	9	22	14	10	12.8	11.6	2	6	9	19.5	M6	2.5	
48	53	70	59.0	66	4	59.7	68.4	75	84	23	56	28	2	6	9	22	14	10	12.8	11.6	2	6	9	19.5	M6	2.5	
50	55	72	62.0	70	4	60.8	69.3	76	93	25	63	31.5	2.5	6	9	23	15	10.5	12.8	11.6	2	6	9	19.5	M6	2.5	
53	58	79	65.0	73	4	63.8	72.3	83	97	25	67	33.5	2.5	6	9	23	15	12	13.5	12.3	2	6	11	23.5	M8	2.5	
55	60	81	67.0	75	4	66.5	75.4	85	97	25	67	33.5	2.5	6	9	23	15	12	14.5	13.3	2	6	11	23.5	M8	2.5	
58	63	84	70.0	78	4	69.5	78.4	88	104	25	74	37	2.5	6	9	23	15	12	14.5	13.3	2	6	11	24.5	M8	2.5	
60	65	86	72.0	80	4	71.5	80.4	95	104	25	74	37	2.5	6	9	23	15	12	14.5	13.3	2	6	11	24.5	M8	2.5	
63	68	89	75.0	83	4	74.5	83.4	93	109	25	79	39.5	2.5	6	9	23	15	12	14.2	13.3	2	6	11	24.5	M8	2.5	
65	70	91	77.0	85	4	76.5	85.4	95	98	25	68	34	2.5	6	9	23	15	12	14.2	13	2	6	11	23.5	M8	2.5	
70	75	99	83.0	92	4	83.0	92.0	105	112.5	28	76.4	38.2	2.5	7	9	26	18	12.5	14.9	13.7	2	6	11.3	25.5	M8	2.5	
75	80	104	88.0	97	4	90.2	99.0	109	112.5	28	76.4	38.2	2.5	7	9	26	18	12.5	14.2	13	2	6	11.3	25.5	M8	2.5	
80	85	109	95.0	105	4	95.2	104.0	114	112.5	28	76	38	3	7	9	26.2	18.2	12.5	15.2	14	2	6	11.3	25	M8	2.5	
85	90	114	100.0	110	4	100.2	109.0	119	112.5	28	76	38	3	7	9	26.2	18.2	13	16.2	15	2	6	12	25.5	M8	2.5	
90	95	119	105.0	115	4	105.2	114.0	124	112.5	28	76	38	3	7	9	26.2	18.2	15	16	14.8	2	6	14	25	M8	2.5	
95	100	124	110.0	120	4	111.6	120.3	129	110.5	28	76	38	3	7	9	25.2	17.2	15	16	14.8	2	6	14	25	M8	2.5	
100	105	129	115.0	125	4	114.5	123.3	134	110.5	28	76	38	3	7	9	25.2	17.2	15	17	15.8	-	-	14	25.5	M8	2.5	
105	115	148	122.2	134.3	5	-	-	153	122	32	82	41	2	10	-	30	20	15	17	15.8	-	-	14	31.5	M8	2.5	
110	120	153	128.2	140.3	5	-	-	158	122	32	82	41	2	10	-	30	20	-	-	-	-	-	-	31.5	M8	-	
115	125	158	136.2	148.3	5	-	-	163	122	32	82	41	2	10	-	30	20	-	-	-	-	-	-	31.5	M8	-	
120	130	163	138.2	150.3	5	-	-	168	122	32	82	41	2	10	-	30	20	-	-	-	-	-	-	31.5	M8	-	
125	135	168	142.2	154.3	5	-	-	173	122	32	82	41	2	10	-	30	20	-	-	-	-	-	-	31.5	M8	-	
130	140	173	146.2	158.3	5	-	-	178	122	32	82	41	2	10	-	30	20	-	-	-	-	-	-	31.5	M8	-	
135	145	178	152.2	164.3	5	-	-	183	122	32	82	41	2	10	-	30	20	-	-	-	-	-	-	31.5	M8	-	
140	150	183	156.2	168.3	5	-	-	188	122	32	82	41	2	10	-	30	20	-	-	-	-	-	-	31.5	M8	-	
145	155	191	161.2	173.3	5	-	-	196	133	34	93	46.5	2	10	-	30	20	-	-	-	-	-	-	35.5	M8	-	
150	160	196	168.2	180.3	5	-	-	201	137	36	93	46.5	2	10	-	32	22	-	-	-	-	-	-	35.5	M8	-	
155	165	201	173.2	185.3	5	-	-	206	141	38	93	46.5	2	12	-	34	24	-	-	-	-	-	-	35.5	M8	-	
160	170	206	178.2	190.3	5	-	-	211	141	38	93	46.5	2	12	-	34	24	-	-	-	-	-	-	35.5	M8	-	
165	175	211	183.2	195.3	5	-	-	216	141	38	93	46.5	2	12	-	34	24	-	-	-	-	-	-	35.5	M8	-	
170	180	216	188.2	200.3	5	-	-	221	141	38	93	46.5	2	12	-	34	24	-	-	-	-	-	-	35.5	M8	-	
175	185	221	193.2	205.3	5	-	-	226	141	38	93	46.5	2	12	-	34	24	-	-	-	-	-	-	35.5	M8	-	
180	190	226	207.5	219.3	5	-	-	231	149	42	93	46.5	2	12	-	38	28	-	-	-	-	-	-	35.5	M8	-	
185	195	231	212.5	224.3	5	-	-	236	149	42	93	46.5	2	12	-	38	28	-	-	-	-	-	-	35.5	M8	-	
190	200	236	217.5	229.3	5	-	-	241	149	42	93	46.5	2	12	-	38	28	-	-	-	-	-	-	35.5	M8	-	
195	205	245	222.5	234.3	5	-	-	250	151	43	95	47.5	2	12	-	38	28	-	-	-	-	-	-	-	M10	-	
200	210	250	227.5	239.3	5	-	-	255	151	43	95	47.5	2	12	-	38	28	-	-	-	-	-	-	-	-	-	-

d<sub>s</sub> > 200 on request

inch size available from size 0.625 to 7.875

Note: Additional technical & dimensional information will be provided on request.

The specifications, drawings, images etc included in this catalogue are intended to be generic and must be interpreted as equivalent or functionally equivalent, more specifically the performance capabilities mentioned in this catalogue is based on optimum values, however the performance of the product is dependent on size, material of construction, media, pressure, temperature, sliding velocity etc and it shall vary from size to size or application to application. Customers are requested to consult with Sealmatic before employing the product from this catalogue for any application.



### Product Description

1. Single seal configuration
2. Balanced design
3. Dependent of direction of rotation
4. For stepped shafts
5. Torque transmission is through the conical spring

### Technical Features

1. Low cost seal solution
2. No damage to the shaft
3. Short installation length available on request

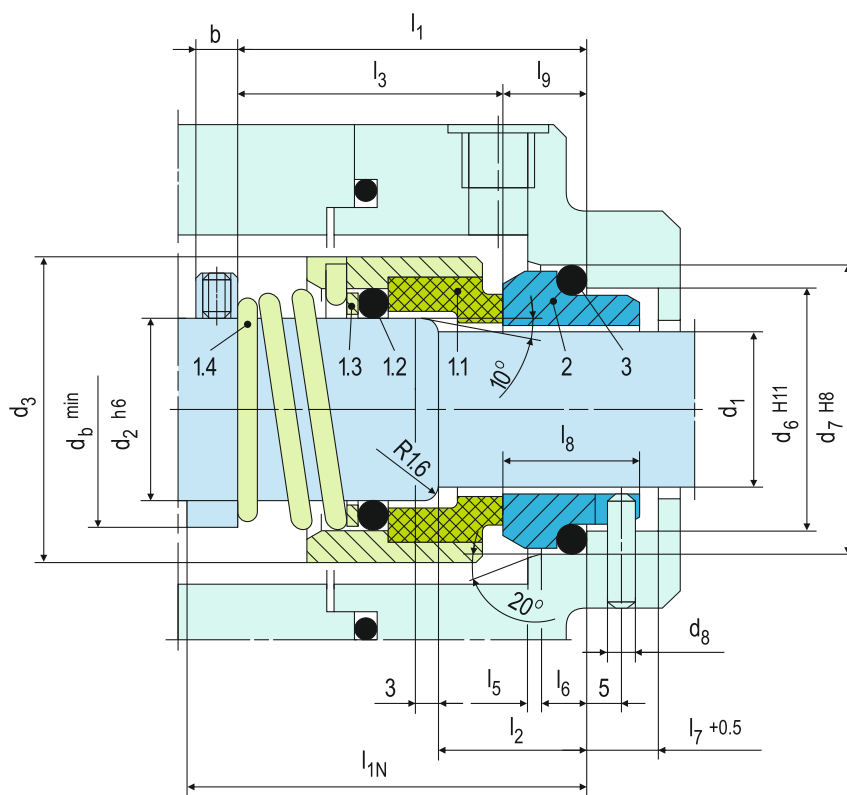

**Note:** The item numbers as depicted above are based on our technical experience and knowledge and are placed in the chronological order of their assembly procedure.

Item	Part no.	Description
1.1	472/473	Seal face
1.2	412.1	O-ring
1.3	474	Thrust ring
1.4	478	Right hand spring
1.4	479	Left hand spring
2	475	Seat (G9)
3	412.2	O-ring

**DIN 24250**

### Typical Industrial Applications

Chemical industry  
Hot water  
Medias with Low solids content (B170GN)  
Water and waste water technology  
Chemical standard pumps  
Water and sewage pumps

### Performance Capabilities

Sizes:  $d_1$  = Upto 80 mm (Upto 3.15")  
Pressure:  $p_1$  = 25 bar (363 PSI)  
Temperature:  $t$  = -50 °C...+220 °C (-58 °F...+430 °F)  
Speed = 15 m/s (50 ft/s)  
Permissible axial movement:  $\pm$  1.0 mm

### Design Variations

#### B120

Dimensions, items and descriptions as for B120N, but with seat G16.

Seal face: Carbon graphite antimony impregnated (A)

Seat G16: Silicon carbide (Q1), CrMo cast steel (S), Aluminium oxide (V)

#### B170GN

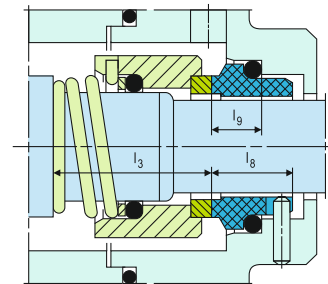

Dimensions, items and descriptions as for B120N, but with shrink-fitted seal face (Q12), item no. 11.

Temperature:  $t$  = -20°C...+180°C (-4°F...+356 °F)

Seal face: Silicon carbide (Q12)

Seat G9: Silicon carbide (Q1, Q2), Carbon graphite antimony impregnated (A), Carbon graphite resin impregnated (B)

#### B170G

Dimensions, items and descriptions as for B120N, but with shrink-fitted seal face (Q12) and seat G16.

Temperature:  $t$  = -20°C...+180°C (-4°F...+356 °F)

Seal face: Silicon carbide (Q12)

Seat G16: Silicon carbide (Q1)

### Materials

Seal face: Carbon graphite antimony impregnated (A)

Seat G9: Silicon carbide (Q1), Special cast CrMo steel (S)

### Standards

EN 12756

## Stationary Seats

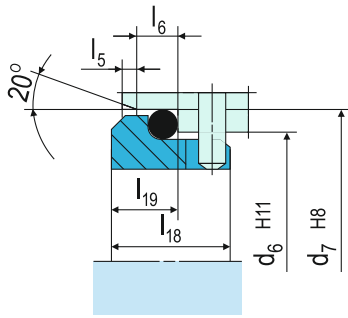

**G16**  
(EN 12756 but  $l_{1k}$  and  $l_2$  are shorter than specified)

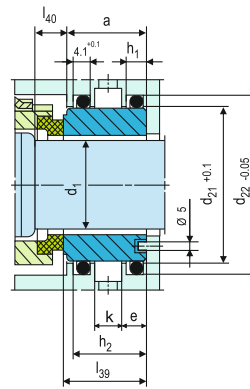

**G115**  
Cooled seat especially for hot water applications. In this case, the dimensions of the B120N rotating unit are modified. Seal designation: B721G115.

### Dimensional Data

Dimensions in millimeter

$d_1$	$d_2$	$d_3$	$d_6$	$d_7$	$d_8$	$d_{21}$	$d_{22}$	$d_b$	$l_{1N}$	$l_1$	$l_2$	$l_3$	$l_5$	$l_6$	$l_7$	$l_8$	$l_9$	$l_{18}$	$l_{19}$	$l_{39}$	$l_{40}$	$a$	$b$	$e$	$h_1$	$h_2$	$k$	$b^*)$
10	14	24	17	21	3	-	-	18	50	35.5	18	25.5	1.5	4	8.5	17.5	10.0	-	-	-	-	-	5	-	-	-	-	8.0
12	16	26	19	23	3	-	-	21	50	36.5	18	26.5	1.5	4	8.5	17.5	10.0	-	-	-	-	-	5	-	-	-	-	8.0
14	18	31	21	25	3	-	-	23	55	39.5	18	29.5	1.5	4	8.5	17.5	10.0	-	-	-	-	-	6	-	-	-	-	8.0
16	20	34	23	27	3	-	-	26	55	41.0	18	31.0	1.5	4	8.5	17.5	10.0	-	-	-	-	-	6	-	-	-	-	8.0
18	22	36	27	33	3	-	-	28	55	44.0	20	32.5	2.0	5	9.0	19.5	11.5	15	7	-	-	6	-	-	-	-	8.0	
20	24	38	29	35	3	-	-	30	60	44.0	20	32.5	2.0	5	9.0	19.5	11.5	15	7	-	-	6	-	-	-	-	8.0	
22	26	40	31	37	3	-	-	31	60	44.0	20	32.5	2.0	5	9.0	19.5	11.5	15	7	-	-	6	-	-	-	-	8.0	
24	28	42	33	39	3	-	-	35	60	44.0	20	32.5	2.0	5	9.0	19.5	11.5	15	7	-	-	6	-	-	-	-	8.0	
25	30	44	34	40	3	-	-	37	60	45.0	20	33.5	2.0	5	9.0	19.5	11.5	15	7	-	-	6	-	-	-	-	8.0	
28	33	47	37	43	3	44.65	50.57	40	65	47.0	20	35.5	2.0	5	9.0	19.5	11.5	15	7	24.0	8.5	24	6	8	6.6	22.6	9	8.0
30	35	49	39	45	3	47.83	53.75	43	65	47.0	20	35.5	2.0	5	9.0	19.5	11.5	15	7	24.5	9.0	24	6	8	6.6	22.6	9	8.0
32	38	54	42	48	3	47.83	53.75	45	65	51.0	20	39.5	2.0	5	9.0	19.5	11.5	15	7	24.5	9.0	24	6	8	6.6	22.6	9	7.5
33	38	54	42	48	3	47.83	53.75	45	65	51.0	20	39.5	2.0	5	9.0	19.5	11.5	15	7	24.5	9.0	24	6	8	6.6	22.6	9	7.5
35	40	56	44	50	3	51.00	56.92	49	65	55.0	20	43.5	2.0	5	9.0	19.5	11.5	15	7	24.5	9.0	24	6	8	6.6	22.6	9	8.0
38	43	59	49	56	4	54.18	60.10	52	75	60.0	23	46.0	2.0	6	9.0	22.0	14.0	16	8	26.0	11.0	24	6	8	6.6	22.6	9	7.5
40	45	61	51	58	4	60.53	66.45	55	75	62.0	23	48.0	2.0	6	9.0	22.0	14.0	16	8	26.0	11.0	24	6	8	6.6	22.6	9	8.0
43	48	64	54	61	4	63.70	69.62	58	75	65.0	23	51.0	2.0	6	9.0	22.0	14.0	16	8	26.0	11.0	24	6	8	6.6	22.6	9	8.0
45	50	66	56	63	4	63.70	69.62	61	75	69.0	23	55.0	2.0	6	9.0	22.0	14.0	16	8	26.0	11.0	24	6	8	6.6	22.6	9	8.0
48	53	69	59	66	4	66.88	72.80	64	85	69.0	23	55.0	2.0	6	9.0	22.0	14.0	16	8	26.0	11.0	24	8	8	6.6	22.6	9	8.0
50	55	71	62	70	4	70.05	75.97	66	85	73.0	25	58.0	2.5	6	9.0	23.0	15.0	17	9.5	26.5	12.5	24	8	8	6.6	22.6	9	8.0
53	58	78	65	73	4	76.40	82.32	69	85	75.0	25	60.0	2.5	6	9.0	23.0	15.0	17	9.5	26.5	12.5	24	8	8	6.6	22.6	9	8.0
55	60	79	67	75	4	76.40	82.32	71	85	75.0	25	60.0	2.5	6	9.0	23.0	15.0	17	9.5	28.5	12.5	26	8	8	6.6	24.6	11	8.0
58	63	83	70	78	4	79.58	85.50	74	85	75.0	25	60.0	2.5	6	9.0	23.0	15.0	18	10.5	28.5	12.5	26	8	8	6.6	24.6	11	8.0
60	65	85	72	80	4	82.75	88.67	77	95	75.0	25	60.0	2.5	6	9.0	23.0	15.0	18	10.5	28.5	12.5	26	8	8	6.6	24.6	11	8.0
63	68	88	75	83	4	85.93	91.85	80	95	75.0	25	60.0	2.5	6	9.0	23.0	15.0	18	10.5	28.5	12.5	26	8	8	6.6	24.6	11	8.0
65	70	90	77	85	4	85.93	91.85	83	95	76.0	25	61.0	2.5	6	9.0	23.0	15.0	18	10.5	28.5	12.5	26	8	8	6.6	24.6	11	10.0
70	75	98	83	92	4	89.10	95.02	88	95	81.0	28	63.0	2.5	7	9.0	26.0	18.0	19	11.5	30.5	14.5	26	8	8	6.6	24.6	11	10.0
75	80	103	88	97	4	98.63	104.55	93	105	86.0	28	68.0	2.5	7	9.0	26.0	18.0	19	11.5	30.5	14.5	26	10	8	6.6	24.6	11	10.0
80	85	109	95	105	4	101.80	107.72	98	105	86.0	28	68.0	3.0	7	9.0	26.2	18.2	19	11.5	30.2	14.0	26	10	8	6.6	24.6	11	10.0

\*)  $l_{1N}$  acc. to EN 12756 is bigger  
inch size available from size 0.375 to 3.125

Note: Additional technical & dimensional information will be provided on request.

The specifications, drawings, images etc included in this catalogue are intended to be generic and must be interpreted as equivalent or functionally equivalent, more specifically the performance capabilities mentioned in this catalogue is based on optimum values, however the performance of the product is dependent on size, material of construction, media, pressure, temperature, sliding velocity etc and it shall vary from size to size or application to application. Customers are requested to consult with Sealmatic before employing the product from this catalogue for any application.

# U700N Single Seals

# Standard Mechanical Seals - Pusher Seals



### Product Description

1. Single seal configuration
2. Unbalanced design
3. Independent of direction of rotation
4. For plain shafts
5. Multiple or wave springs rotary construction
6. Pumping device available for increased efficiency in circulation
7. Sealing with FEP & Spring energized PTFE seals also available on request

### Technical Features

1. Versatile torque transmission available
2. Pumping screw for media with higher viscosity also available
3. Capable of self-cleaning
4. Short installation length available on request
5. Can be employed for low solids content
6. Multifaceted application usage

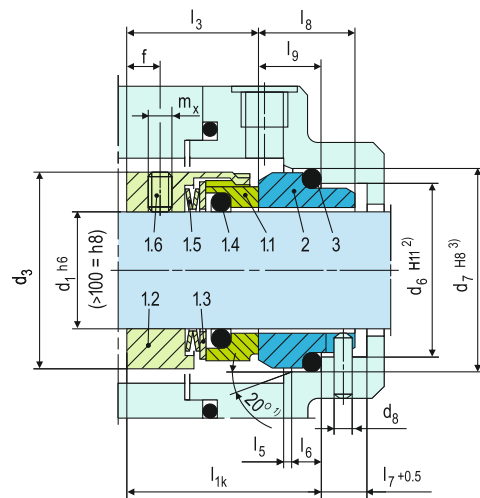

Note: The item numbers as depicted above are based on our technical experience and knowledge and are placed in the chronological order of their assembly procedure.

Item	Part no.	Description
1.1	472	Seal face
1.2	485	Drive collar
1.3	474	Thrust ring
1.4	412.1	O-ring
1.5	477	Spring
1.6	904	Set screw
2	475	Seat (G9)
3	412.2	O-ring

DIN 24250

1) $d_1 > 100$ mm: 30°
2) $d_1 > 100$ mm: +0.1
3) $d_1 > 100$ mm: H7

### Typical Industrial Applications

Chemical industry  
 Food and beverage industry  
 Medias with low solid contents  
 Marine applications  
 Process industry  
 Water and waste water technology  
 Chemical standard pumps  
 Gear wheel feed pumps  
 Multistage pumps  
 Vertical screw pumps

### Performance Capabilities

Sizes:  $d_1 =$  Upto 100 mm (Upto 4.000")  
 Pressure:  $p_1 = 25$  bar (363 PSI)  
 Temperature:  $t = -50$  °C ... +220 °C  
 (-58 °F ... +428 °F)  
 Speed = 20 m/s (66 ft/s)  
 Permissible axial movement:  
 $d_1 =$  up to 25 mm:  $\pm 1.0$  mm  
 $d_1 = 28$  up to 63 mm:  $\pm 1.5$  mm  
 $d_1 =$  from 65 mm:  $\pm 2.0$  mm

### Standards

EN 12756

### Materials

Seal face: Special cast CrMo steel (S), Silicon carbide (Q1, Q2), Aluminium oxide (V)  
 Seat G9: Carbon graphite antimony impregnated (A), Carbon graphite resin impregnated (B), Silicon carbide (Q1\*, Q2\*)  
 Seat G6: Silicon carbide (Q1\*, Q2\*)  
 Seat G13: Carbon graphite antimony impregnated (A), Carbon graphite resin impregnated (B)  
 Secondary seals: EPDM (E), NBR (P), FKM (V), FFKM (K)  
 Springs: CrNiMo steel (G) Metal parts: CrNiMo steel (G), Duplex (G1)  
 \* Cannot be combined with seal face made of S

### Torque Transmissions

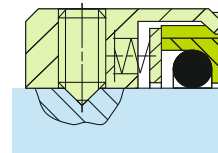

$d_1 > 100$  mm (4.000")  
 Torque transmission by 4 set screws with cone points. Offset: 90°

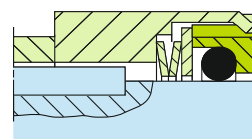

Drive key (U700S2 / U740S2)

### Stationary Seats

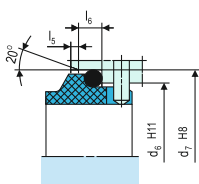

G9  
(EN 12756)

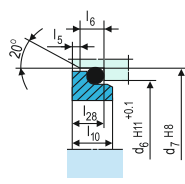

G6  
(EN 12756)

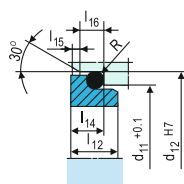

G4

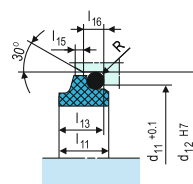

G13

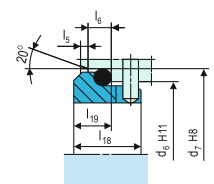

G16  
(EN 12756, but  $l_{1k}$  is shorter than specified)





### Product Description

1. Dual seal configuration
2. Unbalanced design
3. Independent of direction of rotation
4. For plain shafts
5. Multiple or wave springs rotary construction
6. Pumping device available for increased efficiency in circulation (U740F-D)
7. Sealing with FEP & Spring energized PTFE seals also available on request

### Technical Features

1. Versatile torque transmission available
2. Pumping screw for media with higher viscosity also available
3. Capable of self-cleaning
4. Short installation length available on request
5. Can be employed for low solids content
6. Multifaceted application usage
7. EN 12756 (For connection dimensions  $d_1$  upto 100 mm)

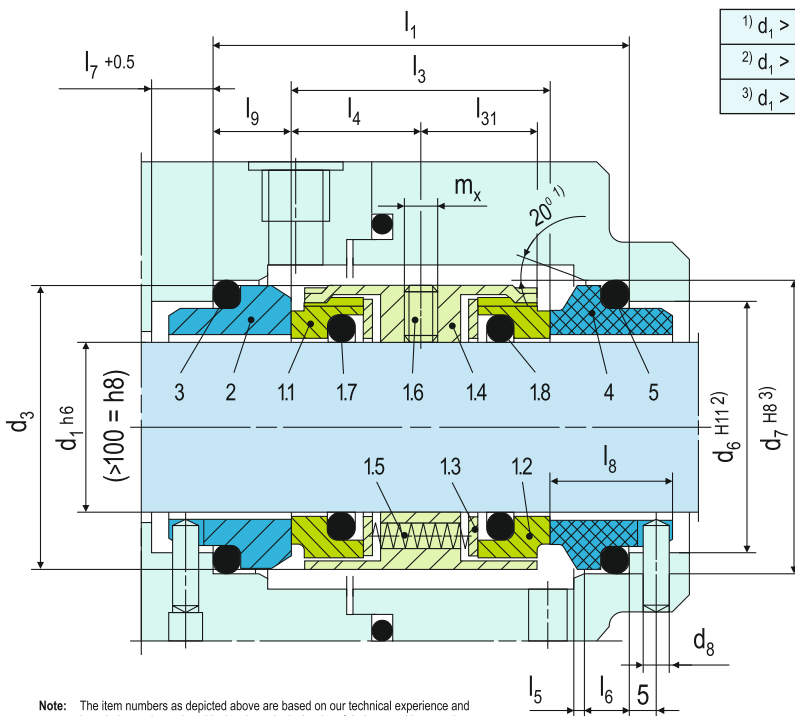

- 1)  $d_1 > 100$  mm:  $30^\circ$
- 2)  $d_1 > 100$  mm:  $+0.1$
- 3)  $d_1 > 100$  mm: H7

### Typical Industrial Applications

Adhesives  
 Chemical industry  
 Low solids content and low abrasive media  
 Media with poor lubrication properties  
 Process industry  
 Toxic and hazardous media  
 Chemical standard pumps

### Design Variations

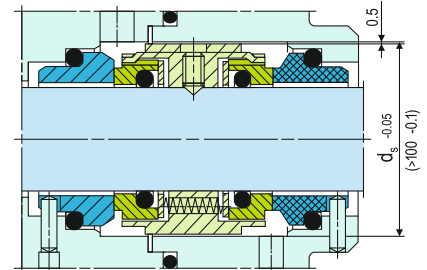

### U740F-D

Dimensions, items and descriptions as for U740-D, but with pumping screw (Item no. 1.4).  
 Dependent on direction of rotation.  
 Viscosity  $\leq$  ISOVG10).

Note: The item numbers as depicted above are based on our technical experience and knowledge and are placed in the chronological order of their assembly procedure.

Item	Part no.	Description
1.1	472.1	Seal face
1.2	472.2	Seal face
1.3	474	Thrust ring
1.4	485	Drive collar
1.5	477	Spring
1.6	904	Set screw
1.7	412.1	O-ring
1.8	412.2	O-ring
2	475.1	Seat (G9)
3	412.3	O-ring
4	475.2	Seat (G9)
5	412.4	O-ring

DIN 24250

### Standards

EN 12756

### Torque Transmissions

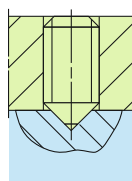

$d_1 > 100$  mm (4.000")  
 Torque transmission by 4 set screws with cone point. Offset:  $90^\circ$

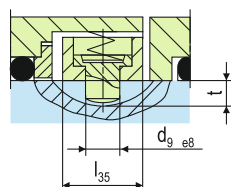

Spring loaded drive pin (U740-D22)

### Performance Capabilities

Sizes:  $d_1 =$  Upto 200 mm (Upto 7.875")

Pressure:  $p_1 = 25$  bar (363 PSI)

Temperature:  $t = -50^\circ\text{C} \dots +220^\circ\text{C}$

( $-58^\circ\text{F} \dots +428^\circ\text{F}$ )

Speed = 20 m/s (66 ft/s)

Permissible axial movement:

$d_1$  upto 100 mm:  $\pm 0.5$  mm

$d_1$  from 100 mm:  $\pm 2.0$  mm

### Materials

Seal face: Special cast CrMo steel (S),

Silicon carbide (Q1, Q2)

Seat G9: Carbon graphite antimony

impregnated (A), Carbon graphite resin

impregnated (B), Silicon carbide (Q1\*, Q2\*)

Seat G4: Silicon carbide (Q1\*, Q2\*)

Seat G6: Silicon carbide (Q1\*, Q2\*)

Seat G13: Carbon graphite antimony

impregnated (A), Carbon graphite resin impregnated (B)

\* Cannot be combined with seal face made of S



## Stationary Seats

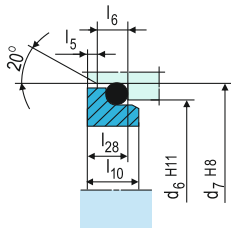

**G6**  
(EN 12756)

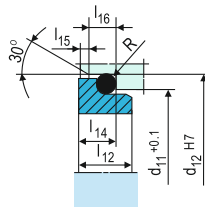

**G4**

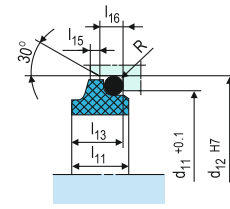

**G13**

## Dimensional Data

### Dimensions in millimeter

d <sub>1</sub>	d <sub>3</sub>	d <sub>6</sub>	d <sub>7</sub>	d <sub>8</sub>	d <sub>9</sub>	d <sub>11</sub>	d <sub>12</sub>	d <sub>8</sub>	l <sub>1</sub>	l <sub>3</sub>	l <sub>4</sub>	l <sub>5</sub>	l <sub>6</sub>	l <sub>7</sub>	l <sub>8</sub>	l <sub>9</sub>	l <sub>10</sub>	l <sub>11</sub>	l <sub>12</sub>	l <sub>13</sub>	l <sub>14</sub>	l <sub>15</sub>	l <sub>16</sub>	l <sub>28</sub>	l <sub>31</sub>	l <sub>35</sub>	m <sub>x</sub>	t	R	
18	33	27.0	33.0	3	4	24.0	30.0	-	61.0	38	19.0	2.0	5	9	19.5	11.5	8.5	12.5	9.0	10.0	8.0	1.5	5	7.5	17.0	15	M5	3.5	1.5	
20	35	29.0	35.0	3	4	29.5	35.0	-	61.0	38	19.0	2.0	5	9	19.5	11.5	8.5	12.5	8.5	9.5	7.5	1.5	5	7.5	17.0	15	M5	3.5	1.5	
22	37	31.0	37.0	3	4	29.5	35.0	42	61.0	38	19.0	2.0	5	9	19.5	11.5	8.5	12.5	8.5	9.5	7.5	1.5	5	7.5	17.0	15	M5	3.5	1.5	
24	39	33.0	39.0	3	4	32.0	38.0	44	61.0	38	19.0	2.0	5	9	19.5	11.5	8.5	12.5	8.5	9.5	7.5	1.5	5	7.5	17.0	15	M5	3.5	1.5	
25	40	34.0	40.0	3	4	32.0	38.0	45	61.0	38	19.0	2.0	5	9	19.5	11.5	8.5	12.5	8.5	9.5	7.5	1.5	5	7.5	17.0	15	M5	3.5	1.5	
28	43	37.0	43.0	3	4	36.0	42.0	47	62.0	39	19.5	2.0	5	9	19.5	11.5	8.5	14.0	10.0	11.0	9.0	1.5	5	7.5	17.5	15	M6	3.5	1.5	
30	45	39.0	45.0	3	4	39.2	45.0	49	62.0	39	19.5	2.0	5	9	19.5	11.5	8.5	14.0	11.5	11.0	10.5	1.5	5	7.5	17.5	15	M6	3.5	1.5	
32	47	42.0	48.0	3	4	42.2	48.0	51	62.0	39	19.5	2.0	5	9	19.5	11.5	8.5	14.0	11.5	11.0	10.5	1.5	5	7.5	17.5	15	M6	3.5	1.5	
33	48	42.0	48.0	3	4	44.2	50.0	51	62.0	39	19.5	2.0	5	9	19.5	11.5	8.5	14.5	12.0	11.5	10.5	1.5	5	7.5	17.5	15	M6	3.5	1.5	
35	50	44.0	50.0	3	4	46.2	52.0	54	62.0	39	19.5	2.0	5	9	19.5	11.5	8.5	14.5	12.0	11.5	11.0	1.5	5	7.5	17.5	15	M6	3.5	1.5	
38	55	49.0	56.0	4	4	49.2	55.0	59	69.0	41	20.5	2.0	6	9	22.0	14.0	10.0	14.5	11.3	11.5	10.3	1.5	5	9.0	18.5	15	M6	3.5	1.5	
40	57	51.0	58.0	4	4	52.2	58.0	61	70.0	42	21.0	2.0	6	9	22.0	14.0	10.0	14.5	11.8	11.5	10.8	1.5	5	9.0	19.0	15	M6	3.5	1.5	
43	60	54.0	61.0	4	4	53.3	62.0	65	70.0	42	21.0	2.0	6	9	22.0	14.0	10.0	17.0	13.2	14.3	12.0	2.0	6	9.0	19.0	15	M6	3.5	2.5	
45	62	56.0	63.0	4	4	55.3	64.0	66	70.0	42	21.0	2.0	6	9	22.0	14.0	10.0	17.0	12.8	14.3	11.6	2.0	6	9.0	19.0	15	M6	3.5	2.5	
48	65	59.0	66.0	4	4	59.7	68.4	69	70.0	42	21.0	2.0	6	9	22.0	14.0	10.0	17.0	12.8	14.3	11.6	2.0	6	9.0	19.0	15	M6	3.5	2.5	
50	67	62.0	70.0	4	4	60.8	69.3	71	73.0	43	21.5	2.5	6	9	23.0	15.0	10.5	17.0	12.8	14.3	11.6	2.0	6	9.5	19.5	15	M6	3.5	2.5	
53	70	65.0	73.0	4	4	63.8	72.3	75	73.0	43	21.5	2.5	6	9	23.0	15.0	12.0	17.0	13.5	14.3	12.3	2.0	6	11.0	19.5	15	M6	3.5	2.5	
55	72	67.0	75.0	4	4	66.5	75.4	76	73.0	43	21.5	2.5	6	9	23.0	15.0	12.0	18.0	14.5	15.3	13.3	2.0	6	11.0	19.5	15	M8	3.5	2.5	
58	79	70.0	78.0	4	5	69.5	78.4	83	86.0	56	28.0	2.5	6	9	23.0	15.0	12.0	18.0	14.5	15.3	13.3	2.0	6	11.0	23.5	19	M8	3.5	2.5	
60	81	72.0	80.0	4	5	71.5	80.4	85	86.0	56	28.0	2.5	6	9	23.0	15.0	12.0	18.0	14.5	15.3	13.3	2.0	6	11.0	23.5	19	M8	3.5	2.5	
63	84	75.0	83.0	4	5	74.5	83.4	88	85.0	55	27.5	2.5	6	9	23.0	15.0	12.0	18.0	14.2	15.3	13.3	2.0	6	11.0	24.5	19	M8	3.5	2.5	
65	86	77.0	85.0	4	5	76.5	85.4	95	85.0	55	27.5	2.5	6	9	23.0	15.0	12.0	18.0	14.2	15.3	13.0	2.0	6	11.0	24.5	19	M8	3.5	2.5	
68	89	81.0	90.0	4	5	82.7	91.5	93	91.0	55	27.5	2.5	7	9	26.0	18.0	12.5	19.0	14.9	16.0	13.7	2.0	6	11.3	24.5	19	M8	3.5	2.5	
70	91	83.0	92.0	4	5	83.0	92.0	95	92.0	56	28.0	2.5	7	9	26.0	18.0	12.5	18.0	14.2	15.3	13.0	2.0	6	11.3	23.5	19	M8	3.5	2.5	
75	99	88.0	97.0	4	5	90.2	99.0	105	92.0	56	28.0	2.5	7	9	26.0	18.0	12.5	18.0	15.2	15.3	14.0	2.0	6	11.3	25.5	19	M8	3.5	2.5	
80	104	95.0	105.0	4	5	95.2	104.0	109	92.5	56	28.0	3.0	7	9	26.2	18.2	13.0	19.0	16.2	16.3	15.0	2.0	6	12.0	25.5	19	M8	3.5	2.5	
85	109	100.0	110.0	4	5	100.2	109.0	114	92.5	56	28.0	3.0	7	9	26.2	18.2	15.0	19.0	16.0	16.3	14.8	2.0	6	14.0	25.0	19	M8	3.5	2.5	
90	114	105.0	115.0	4	5	105.2	114.0	119	92.5	56	28.0	3.0	7	9	26.2	18.2	15.0	19.0	16.0	16.3	14.8	2.0	6	14.0	25.5	19	M8	3.5	2.5	
95	119	110.0	120.0	4	5	111.6	120.3	124	90.5	56	28.0	3.0	7	9	25.2	17.2	15.0	20.0	17.0	17.3	15.8	2.0	6	14.0	25.0	19	M8	3.5	2.5	
100	124	115.0	125.0	4	5	114.5	123.3	129	90.5	56	28.0	3.0	7	9	25.2	17.2	15.0	20.0	17.0	17.3	15.8	2.0	6	14.0	25.0	19	M8	3.5	2.5	
105	138	122.2	134.3	5	7	-	-	143	108.0	68	34.0	2.0	10	-	30.0	20.0	-	-	-	-	-	-	-	-	-	30.5	22	M8	3.5	-
110	143	128.2	140.3	5	7	-	-	148	110.0	70	35.0	2.0	10	-	30.0	20.0	-	-	-	-	-	-	-	-	-	31.5	22	M8	3.5	-
115	148	136.2	148.3	5	7	-	-	153	110.0	70	35.0	2.0	10	-	30.0	20.0	-	-	-	-	-	-	-	-	-	31.5	22	M8	3.5	-
120	153	138.2	150.3	5	7	-	-	158	110.0	70	35.0	2.0	10	-	30.0	20.0	-	-	-	-	-	-	-	-	-	31.5	22	M8	3.5	-
125	158	142.2	154.3	5	7	-	-	163	110.0	70	35.0	2.0	10	-	30.0	20.0	-	-	-	-	-	-	-	-	-	31.5	22	M8	3.5	-
130	163	146.2	158.3	5	7	-	-	168	110.0	70	35.0	2.0	10	-	30.0	20.0	-	-	-	-	-	-	-	-	-	31.5	22	M8	3.5	-
135	168	152.2	164.3	5	7	-	-	173	110.0	70	35.0	2.0	10	-	30.0	20.0	-	-	-	-	-	-	-	-	-	31.5	22	M8	3.5	-
140	173	156.2	168.3	5	7	-	-	178	110.0	70	35.0	2.0	10	-	30.0	20.0	-	-	-	-	-	-	-	-	-	31.5	22	M8	3.5	-
145	178	161.2	173.3	5	7	-	-	183	110.0	70	35.0	2.0	10	-	30.0	20.0	-	-	-	-	-	-	-	-	-	31.5	22	M8	3.5	-
150	183	166.2	180.3	5	7	-	-	188	114.0	70	35.0	2.0	10	-	32.0	22.0	-	-	-	-	-	-	-	-	-	31.5	22	M8	3.5	-
155	191	173.2	185.3	5	7	-	-	196	127.0	79	39.5	2.0	12	-	34.0	24.0	-	-	-	-	-	-	-	-	-	35.5	22	M8	3.5	-
160	196	178.2	190.3	5	7	-	-	201	127.0	79	39.5	2.0	12	-	34.0	24.0	-	-	-	-	-	-	-	-	-	35.5	22	M8	3.5	-
165	201	183.2	195.3	5	7	-	-	206	127.0	79	39.5	2.0	12	-	34.0	24.0	-	-	-	-	-	-	-	-	-	35.5	22	M8	3.5	-
170	206	188.2	200.3	5	7	-	-	211	127.0	79	39.5	2.0	12	-	34.0	24.0	-	-	-	-	-	-	-	-	-	35.5	22	M8	3.5	-
175	211	193.2	205.3	5	7	-	-	216	127.0	79	39.5	2.0	12	-	34.0	24.0	-	-	-	-	-	-	-	-	-	35.5	22	M8	3.5	-
180	216	207.5	219.3	5	7	-	-	221	135.0	79	39.5	2.0	12	-	38.0	28.0	-	-	-	-	-	-	-	-	-	35.5	22	M8	3.5	-
185	221	212.5	224.3	5	7	-	-	226	135.0	79	39.5	2.0	12	-	38.0	28.0	-	-	-	-	-	-	-	-	-	35.5	22	M8	3.5	-
190	226	217.5	229.3	5	7	-	-	231	135.0	79	39.5	2.0	12	-	38.0	28.0	-	-	-	-	-	-	-	-	-	35.5	22	M8	3.5	-
195	231	222.5	234.3	5	7	-	-	236	135.0	79	39.5	2.0	12	-	38.0	28.0	-	-	-	-	-	-	-	-	-	35.5	22	M8	3.5	-
200	236	227.5	239.3	5	7																									



### Product Description

1. Single seal configuration
2. Unbalanced Design
3. Dependent of direction of rotation
4. For plain shafts
5. Torque transmission is through the conical spring

### Technical Features

1. Low cost seal solution
2. No damage to the shaft
3. Short installation length available on request
4. Can be employed for low solids content

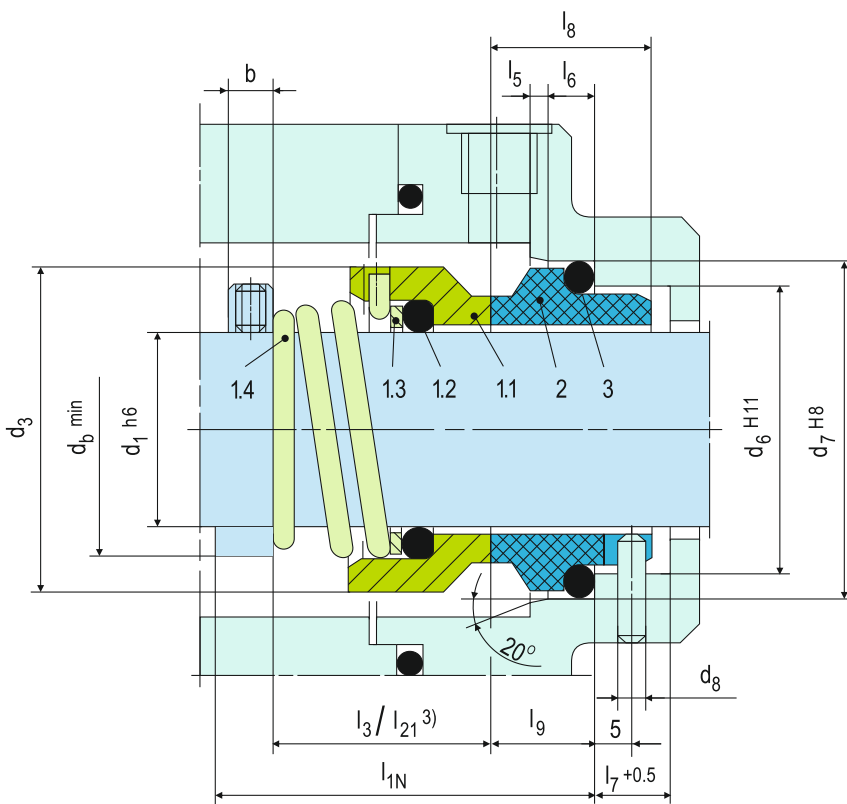

**Note:** The item numbers as depicted above are based on our technical experience and knowledge and are placed in the chronological order of their assembly procedure.

### Typical Industrial Applications

- Chemical industry
- Food and beverage industry
- Process industry
- Water and waste water technology
- Chemical standard pumps
- Eccentric screw pumps
- Submersible pumps

### Materials

Seal face: Special cast CrMo steel (S)  
 Seat G9: Carbon graphite antimony impregnated (A), Carbon graphite resin impregnated (B)

### Performance Capabilities

Sizes:  $d_1 =$  Upto 80 mm (Upto 3.15")  
 Pressure:  $p_1 =$  10 bar (145 PSI)  
 Temperature:  $t = -20\text{ }^\circ\text{C} \dots +140\text{ }^\circ\text{C}$   
 (-4 °F ... +284 °F)  
 Speed: = 15 m/s (50 ft/s)  
 Permissible axial movement:  $\pm 1.0$  mm

### Standards

EN 12756

Item	Part no.	Description
1.1	472	Seal face
1.2	412.1	O-ring
1.3	474	Thrust ring
1.4	478	Right hand spring
1.4	479	Left hand spring
2	475	Seat (G9)
3	412.2	O-ring
<b>DIN 24250</b>		

### Stationary Seats

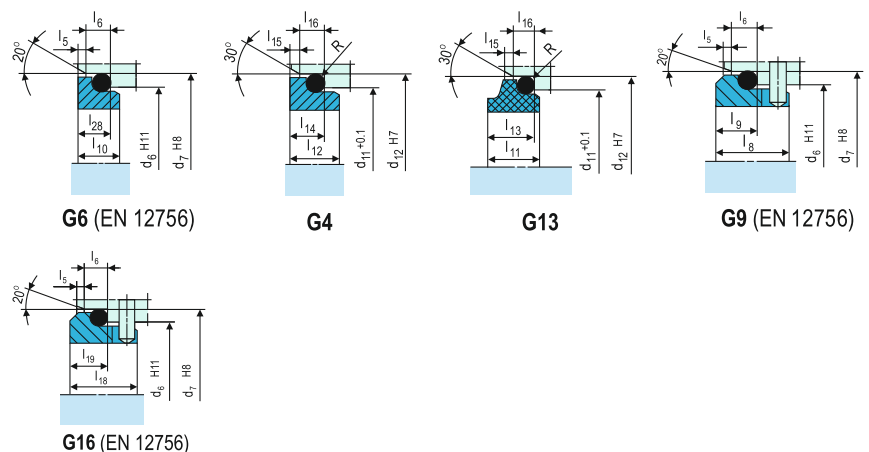

## Design Variations

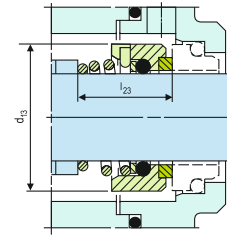
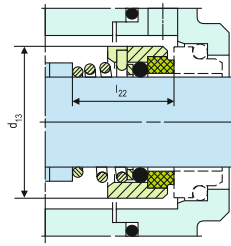

### U300

Items and description as U300N.  
 Seal face: Special cast CrMo steel (S)  
 Seat G13: Carbon graphite antimony impregnated (A), Carbon graphite resin impregnated (B)

### U320

Items and descriptions as for type U300N, but with carbon graphite seal face shrink-fitted to the seal face carrier (Item no. 11).  
 Seal face: Carbon graphite antimony impregnated (A), Carbon graphite resin impregnated (B)  
 Seat G4 : special cast CrMo steel (S), Silicon carbide (Q1, Q2)  
 Seat G6 (U320N4): Special cast CrMo steel (S), Silicon carbide (Q1, Q2)  
 Seat G9 (U320N): Silicon carbide (Q1, Q2)  
 Seat G6 also available in A, B = G30 (longer installation length than G6)

### U370G

Items and descriptions as for type U300N, but with shrink fitted silicon carbide seal face to the seal face carrier (Item no. 1.1).  
 Shaft diameter: d<sub>1</sub> = Upto 80 mm (Upto ... 3.15")  
 Temperature: t = -20 °C ... +180 °C (-4 °F ... +355 °F)  
 Speed = 10 m/s (33 ft/s)  
 Seal face: Silicon carbide (Q12, Q22), Tungsten carbide (U22)  
 Seat G4: Silicon carbide (Q1, Q2)  
 Seat G13: Carbon graphite antimony impregnated (A), Carbon graphite resin impregnated (B)  
 Seat G6 (U370GN4): Silicon carbide (Q1, Q2)  
 Seat G9 (U370GN): Carbon graphite antimony impregnated (A), Carbon graphite resin impregnated (B), Silicon carbide (Q1, Q2)  
 Seat G6 also available in A, B = G30 (longer installation length than G6)

## Dimensional Data

### Dimensions in millimeter

d <sub>1</sub>	d <sub>3</sub>	d <sub>6</sub>	d <sub>7</sub>	d <sub>8</sub>	d <sub>11</sub> <sup>1)</sup>	d <sub>12</sub> <sup>1)</sup>	d <sub>13</sub>	d <sub>b</sub>	l <sub>1N</sub>	l <sub>3</sub> <sup>3)</sup>	l <sub>5</sub>	l <sub>6</sub>	l <sub>7</sub>	l <sub>8</sub>	l <sub>9</sub>	l <sub>10</sub>	l <sub>11</sub>	l <sub>12</sub>	l <sub>13</sub>	l <sub>14</sub>	l <sub>15</sub>	l <sub>16</sub>	l <sub>18</sub>	l <sub>19</sub>	l <sub>21</sub> <sup>3)</sup>	l <sub>22</sub>	l <sub>23</sub>	l <sub>28</sub>	b <sup>2)</sup>	R
6	14	-	-	-	11.5	16.0	16	8	-	-	-	-	-	-	-	-	9.0	6.5	7.1	5.6	1.2	3.8	-	-	10.5	11.9	-	-	-	1.2
8	18	-	-	-	15.5	19.2	18	11	-	-	-	-	-	-	-	-	9.0	8.0	7.1	7.0	1.2	3.8	-	-	15.5	16.9	-	-	-	1.2
10*	19	17	21	3	15.5	19.2	20	13	40	15.5	1.5	4	8.5	17.5	10.0	7.5	9.0	7.5	7.1	6.6	1.2	3.8	-	-	15.5	16.9	-	6.6	(8)	1.2
12*	21	19	23	3	17.5	21.6	22	16	40	16.0	1.5	4	8.5	17.5	10.0	7.5	10.0	6.5	7.6	5.6	1.2	3.8	-	-	15.5	17.4	-	6.6	(8)	1.2
14*	23	21	25	3	20.5	24.6	24	18	40	16.5	1.5	4	8.5	17.5	10.0	7.5	10.0	6.5	7.6	5.6	1.2	3.8	-	-	15.5	17.4	16.5	6.6	(8)	1.2
15	24	-	-	-	20.5	24.6	25	19	-	-	-	-	-	-	-	-	11.0	7.5	8.6	6.6	1.2	3.8	-	-	15.5	17.4	-	-	-	1.2
16*	26	23	27	3	22.0	28.0	26	21	40	18.0	1.5	4	8.5	17.5	10.0	7.5	11.5	8.5	9.0	7.5	1.5	5.0	-	-	17.5	19.5	16.5	6.6	(8)	1.5
18*	29	27	33	3	24.0	30.0	31	23	45	19.5	2.0	5	9.0	19.5	11.5	8.5	12.5	9.0	10.0	8.0	1.5	5.0	15	7	18.5	20.5	18.0	7.5	(8)	1.5
20*	31	29	35	3	29.5	35.0	34	26	45	22.0	2.0	5	9.0	19.5	11.5	8.5	12.5	8.5	9.5	7.5	1.5	5.0	15	7	20.0	22.0	19.0	7.5	(8)	1.5
22*	33	31	37	3	29.5	35.0	36	28	45	21.5	2.0	5	9.0	19.5	11.5	8.5	12.5	8.5	9.5	7.5	1.5	5.0	15	7	21.5	23.5	20.5	7.5	(8)	1.5
24*	35	33	39	3	32.0	38.0	38	30	50	23.5	2.0	5	9.0	19.5	11.5	8.5	12.5	8.5	9.5	7.5	1.5	5.0	15	7	23.0	25.0	22.0	7.5	(8)	1.5
25*	36	34	40	3	32.0	38.0	39	31	50	26.5	2.0	5	9.0	19.5	11.5	8.5	12.5	8.5	9.5	7.5	1.5	5.0	15	7	24.5	26.5	23.5	7.5	(8)	1.5
26	37	-	-	-	34.0	40.0	40	32	-	-	-	-	9.0	-	-	-	13.0	9.0	10.0	8.0	1.5	5.0	-	-	24.5	26.5	23.5	-	-	1.5
28*	40	37	43	3	36.0	42.0	42	35	50	26.5	2.0	5	9.0	19.5	11.5	8.5	14.0	10.0	11.0	9.0	1.5	5.0	15	7	24.5	26.5	24.5	7.5	(8)	1.5
30*	43	39	45	3	39.2	45.0	44	37	50	26.5	2.0	5	9.0	19.5	11.5	8.5	14.0	11.5	11.0	10.5	1.5	5.0	15	7	24.5	25.0	24.5	7.5	(8)	1.5
32*	46	42	48	3	42.2	48.0	46	39	55	28.5	2.0	5	9.0	19.5	11.5	8.5	14.0	11.5	11.0	10.5	1.5	5.0	15	7	28.0	28.5	28.0	7.5	(8)	1.5
33*	47	42	48	3	-	-	47	40	55	28.5	2.0	5	9.0	19.5	11.5	8.5	-	12.0	-	-	-	-	15	7	-	-	-	7.5	(8)	1.5
35*	49	44	50	3	46.2	52.0	49	43	55	28.5	2.0	5	9.0	19.5	11.5	8.5	14.5	12.0	11.5	11.0	1.5	5.0	15	7	28.0	28.5	28.0	7.5	(8)	1.5
38*	53	49	56	4	49.2	55.0	54	45	55	33.5	2.0	6	9.0	22.0	14.0	10.0	14.5	11.3	11.5	10.3	1.5	5.0	16	8	31.0	32.2	31.0	9.0	7.5	1.5
40*	56	51	58	4	52.2	58.0	56	49	55	36.0	2.0	6	9.0	22.0	14.0	10.0	14.5	11.8	11.5	10.8	1.5	5.0	16	8	34.0	34.7	34.0	9.0	(8)	1.5
42	59	-	-	-	53.3	62.0	58	52	-	-	-	-	9.0	-	-	-	17.0	13.2	14.3	12.0	2.0	6.0	-	-	35.0	37.3	35.0	-	-	2.5
43*	59	54	61	4	-	-	59	52	60	38.5	2.0	6	9.0	22.0	14.0	10.0	-	13.2	-	-	2.0	-	16	8	-	-	-	9.0	7.5	2.5
45*	61	56	63	4	55.3	64.0	61	55	60	39.5	2.0	6	9.0	22.0	14.0	10.0	17.0	12.8	14.3	11.6	2.0	6.0	16	8	36.5	39.2	36.5	9.0	(8)	2.5
48*	64	59	66	4	59.7	68.4	64	58	60	46.0	2.0	6	9.0	22.0	14.0	10.0	17.0	12.8	14.3	11.6	2.0	6.0	16	8	42.0	44.7	42.0	9.0	(8)	2.5
50*	66	62	70	4	60.8	69.3	66	61	60	45.0	2.5	6	9.0	23.0	15.0	10.5	17.0	12.8	14.3	11.6	2.0	6.0	17	9.5	43.0	45.7	43.0	9.5	(8)	2.5
53*	69	65	73	4	-	-	69	64	70	47.0	2.5	6	9.0	23.0	15.0	12.0	-	13.5	-	-	-	-	17	9.5	-	-	-	11.0	8	2.5
55*	71	67	75	4	66.5	75.4	71	66	70	49.0	2.5	6	9.0	23.0	15.0	12.0	18.0	14.5	15.3	13.3	2.0	6.0	17	9.5	47.0	49.0	47.0	11.0	(8)	2.5
58*	76	70	78	4	69.5	78.4	78	69	70	55.0	2.5	6	9.0	23.0	15.0	12.0	18.0	14.5	15.3	13.3	2.0	6.0	18	10.5	50.0	52.0	50.0	11.0	(8)	2.5
60*	78	72	80	4	71.5	80.4	79	71	70	55.0	2.5	6	9.0	23.0	15.0	12.0	18.0	14.5	15.3	13.3	2.0	6.0	18	10.5	51.0	55.0	51.0	11.0	(8)	2.5
63*	83	75	83	4	-	-	83	74	70	55.0	2.5	6	9.0	23.0	15.0	12.0	-	14.2	-	-	-	-	18	10.5	-	-	-	11.0	(8)	2.5
65*	84	77	85	4	76.5	85.4	85	77	80	55.0	2.5	6	9.0	23.0	15.0	12.0	18.0	14.2	15.3	13.0	2.0	6.0	18	10.5	52.0	54.3	52.0	11.0	(8)	2.5
68*	88	81	90	4	82.7	91.5	88	80	80	55.0	2.5	7	9.0	26.0	18.0	12.5	19.0	14.9	16.0	13.7	2.0	6.0	18.5	11.0	53.0	55.3	52.7	11.3	(8)	2.5
70*	90	83	92	4	83.0	92.0	90	83	80	57.0	2.5	7	9.0	26.0	18.0	12.5	18.0	14.2	15.3	13.0	2.0	6.0	19	11.5	54.0	56.3	54.0	11.3	(10)	2.5
75*	98	88	97	4	90.2	99.0	98	88	80	62.0	2.5	7	9.0	26.0	18.0	12.5	18.0	15.2	15.3	14.0	2.0	6.0	19	11.5	55.0	56.3	54.0	11.3	(10)	2.5
80*	100	95	105	4	95.2	104.0	103	93	90	61.8	3.0	7	9.0	26.2	18.2	13.0	19.0	16.2	16.3	15.0	2.0	6.0	19	11.5	58.0	59.3	58.0	12.0	10	2.5

1) Fitting dimensions d<sub>11</sub> and d<sub>12</sub> only apply to type U370G with d<sub>1</sub> > 16mm

2) Dimensions in brackets lie either above or below l<sub>1N</sub>

3) l<sub>3</sub> valid for U3...N, l<sub>21</sub> valid for U300

\*) According to EN 12756

inch size also available from size 0.375 to 3.125

Note: Additional technical & dimensional information will be provided on request.

The specifications, drawings, images etc included in this catalogue are intended to be generic and must be interpreted as equivalent or functionally equivalent, more specifically the performance capabilities mentioned in this catalogue is based on optimum values, however the performance of the product is dependent on size, material of construction, media, pressure, temperature, sliding velocity etc and it shall vary from size to size or application to application. Customers are requested to consult with Sealmatic before employing the product from this catalogue for any application.



### Product Description

1. Single seal configuration
2. Unbalanced Design
3. Dependent of direction of rotation
4. For plain shafts
5. Torque transmission is through the conical spring

### Technical Features

1. Low cost seal solution
2. No damage to the shaft
3. Short installation length available on request

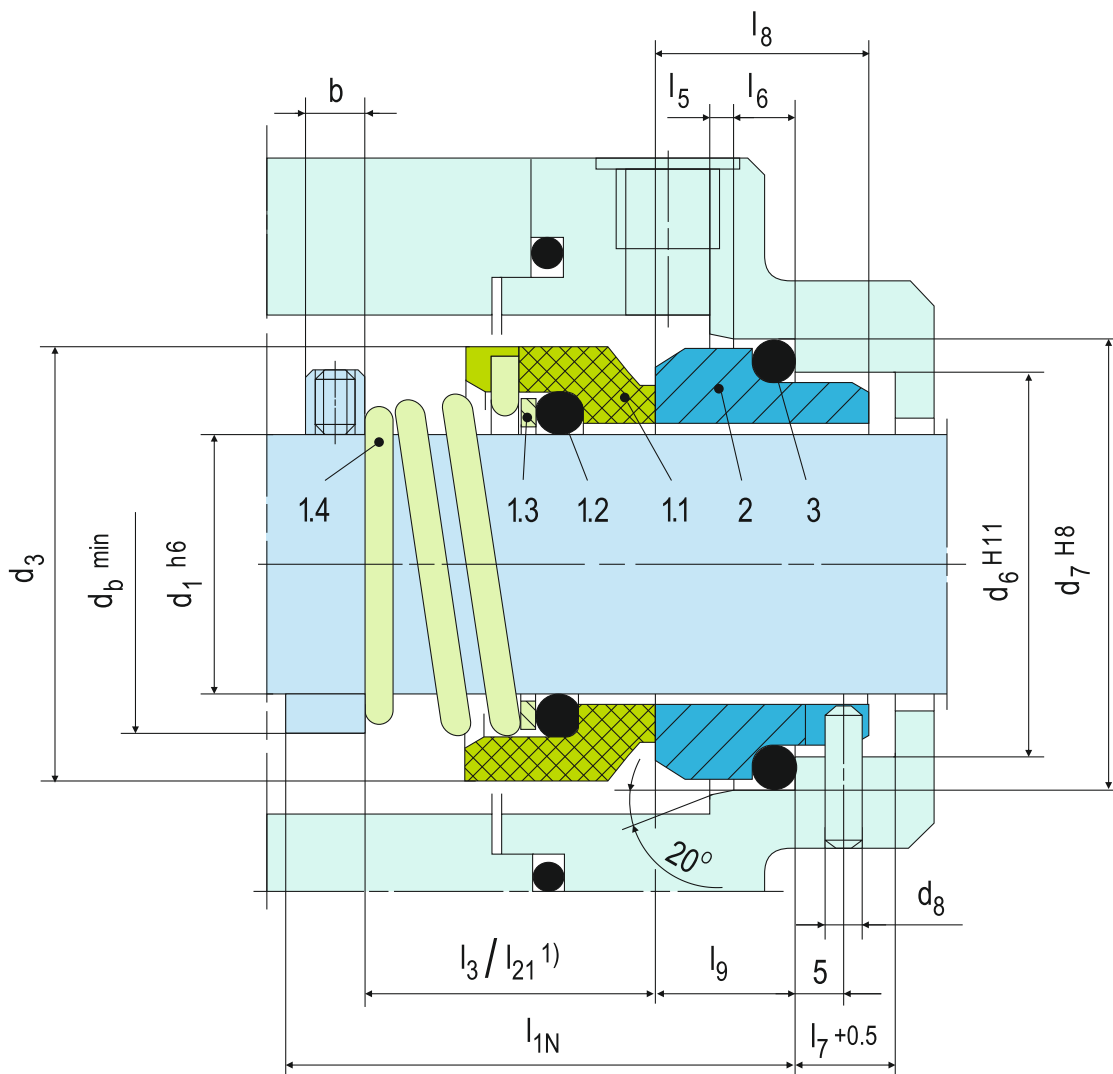

**Note:** The item numbers as depicted above are based on our technical experience and knowledge and are placed in the chronological order of their assembly procedure.

Item	Part no.	Description
1.1	472	Seal face
1.2	412.1	O-ring
1.3	474	Thrust ring
1.4	478	Right hand spring
1.4	479	Left hand spring
2	475	Seat (G9)
3	412.2	O-ring
<b>DIN 24250</b>		

### Performance Capabilities

Shaft diameter:  $d_1 =$  Upto 38 mm (Upto 1.500")  
 Pressure:  $p_1 =$  10 bar (145 PSI)  
 Temperature:  $t =$  -20 °C ... +140 °C  
 (-4 °F ... +284 °F)  
 Speed = 15 m/s (50 ft/s)  
 Permissible axial movement:  $\pm 1.0$  mm

### Typical Industrial Applications

Chemical industry  
 Food and beverage industry  
 Food processing  
 Pulp and paper industry  
 Water and waste water technology

### Standards

EN 12756

### Notes

Seal face: Carbon graphite resin impregnated (B)  
 Seat G9 : Silicon carbide (Q1, Q2),  
 Special cast CrMo steel (S), Aluminium oxide (V)

### Stationary Seats

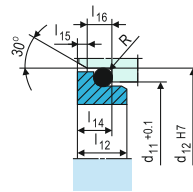

G4

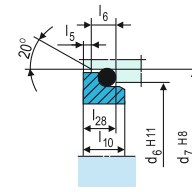

G6  
(EN 12756)

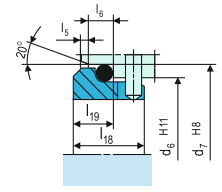

G16  
(EN 12756)

### Design Variations

#### U200

Rotating unit U200 with seat G4 or G16 (shorter installation length).  
 Seal face: Carbon graphite resin impregnated (B)  
 Seat G4 : Silicon carbide (Q1), Special cast CrMo steel (S)  
 Seat G16 : Silicon carbide (Q1, Q2), Special cast CrMo steel (S), Aluminium oxide (V)

#### U200N4

Rotating unit U200 with seat G6.  
 Seal face: Carbon graphite resin impregnated (B)  
 Seat G6: Silicon carbide (Q1), Special cast CrMo steel (S)

### Dimensional Data

#### Dimensions in millimeter

$d_1$	$d_3$	$d_6$	$d_7$	$d_8$	$d_{11}$	$d_{12}$	$d_b$	$l_{1N}$	$l_3^{(1)}$	$l_5$	$l_6$	$l_7$	$l_8$	$l_9$	$l_{10}$	$l_{12}$	$l_{14}$	$l_{15}$	$l_{16}$	$l_{18}$	$l_{19}$	$l_{21}^{(1)}$	$l_{28}$	$b$	$R$
6	15	-	-	-	11.8	16.0	8	-	-	-	-	-	-	-	-	6.5	5.6	1.2	3.8	-	-	10.9	-	-	1.2
8	18	-	-	-	15.5	19.2	11	-	-	-	-	-	-	-	-	8.0	7.0	1.2	3.8	-	-	15.5	-	-	1.2
10	20	17	21	3	15.5	19.2	13	40	17.5	1.5	4	8.5	17.5	10.0	7.5	7.5	6.6	1.2	3.8	-	-	15.9	6.6	8	1.2
12	22	19	23	3	17.5	21.6	16	40	17.5	1.5	4	8.5	17.5	10.0	7.5	8.0	7.0	1.2	3.8	-	-	16.0	6.6	8	1.2
14	25	21	25	3	20.5	24.6	18	40	17.5	1.5	4	8.5	17.5	10.0	7.5	8.0	7.0	1.2	3.8	-	-	16.0	6.6	8	1.2
15	27	-	-	-	20.5	24.6	19	-	-	-	-	-	-	-	-	7.5	6.6	1.2	3.8	-	-	17.4	-	-	1.2
16	27	23	27	3	22.0	28.0	21	40	19.5	1.5	4	8.5	17.5	10.0	7.5	8.5	7.5	1.5	5.0	-	-	19.0	6.6	8	1.5
18	30	27	33	3	24.0	30.0	23	45	20.5	2.0	5	9.0	19.5	11.5	8.5	9.0	8.0	1.5	5.0	15	7	20.5	7.5	8	1.5
20	32	29	35	3	29.5	35.0	26	45	22	2.0	5	9.0	19.5	11.5	8.5	8.5	7.5	1.5	5.0	15	7	22.0	7.5	8	1.5
22	35	31	37	3	29.5	35.0	28	45	23.5	2.0	5	9.0	19.5	11.5	8.5	8.5	7.5	1.5	5.0	15	7	23.5	7.5	8	1.5
24	38	33	39	3	32.0	38.0	30	50	25	2.0	5	9.0	19.5	11.5	8.5	8.5	7.5	1.5	5.0	15	7	25.0	7.5	8	1.5
25	40	34	40	3	32.0	38.0	31	50	26.5	2.0	5	9.0	19.5	11.5	8.5	8.5	7.5	1.5	5.0	15	7	26.5	7.5	8	1.5
26	41	-	-	-	34.0	40.0	32	-	-	-	-	-	-	-	-	9.0	8.0	1.5	5.0	-	-	26.5	-	-	1.5
28	43	37	43	3	36.0	42.0	35	50	26.5	2.0	5	9.0	19.5	11.5	8.5	10.0	9.0	1.5	5.0	15	7	26.5	7.5	8	1.5
30	47	-	-	-	39.2	45.0	37	-	-	-	-	-	-	11.5	-	11.5	10.5	1.5	5.0	15	7	25.0	-	-	1.5
32	48	-	-	-	42.2	48.0	39	-	-	-	-	-	-	11.5	-	13.0	10.5	1.5	5.0	15	7	28.5	-	-	1.5
35	53	-	-	-	46.2	52.0	43	-	-	-	-	-	-	11.5	-	13.5	11.0	1.5	5.0	15	7	28.5	-	-	1.5
38	56	-	-	-	49.2	55.0	47	-	-	-	-	-	-	14.0	-	13.0	10.3	1.5	5.0	16	8	32.0	-	-	1.5

1)  $l_3$  valid for U200N,  $l_{21}$  valid for U200

According to EN 12756

inch sizes also available from size 0.250 to 1.500

Note: Additional technical & dimensional information will be provided on request.

The specifications, drawings, images etc included in this catalogue are intended to be generic and must be interpreted as equivalent or functionally equivalent, more specifically the performance capabilities mentioned in this catalogue is based on optimum values, however the performance of the product is dependent on size, material of construction, media, pressure, temperature, sliding velocity etc and it shall vary from size to size or application to application. Customers are requested to consult with Sealmatic before employing the product from this catalogue for any application.



### Product Description

1. Single seal configuration
2. Unbalanced design
3. Independent of direction of rotation
4. For plain shafts
5. Rotary elastomer bellows design

### Technical Features

1. Low cost seal solution
2. Suitable for mild sterile applications
3. No damage to the shaft
4. Can be employed for low solids content
5. Multifaceted application usage

### Typical Industrial Applications

Food and beverage industry	Cooling fluids
Multi-stage pumps (non-drive side)	Circulating pumps
Media with low solids content	Oil applications
Pressure oils for bio diesel fuels	
Water and waste water technology	Chemical industry
Water and waste water pumps	Submersible pumps

### Performance Capabilities

Shaft diameter:  $d_1 = 10 \dots 100 \text{ mm}$  (0.375" ... 4")  
 Pressure:  $p_1 = 12 \text{ bar}$  (174 PSI), vacuum up to 0.5 bar (7.25 PSI), up to 1 bar (14.5 PSI) with seat locking  
 Temperature:  $t = -20 \text{ }^\circ\text{C} \dots +140 \text{ }^\circ\text{C}$  (-4 °F ... +284 °F)  
 Speed = 10 m/s (33 ft/s)  
 Axial movement:  $\pm 0.5 \text{ mm}$

### Notes

A modular principle comprising a bellows unit for each shaft diameter and a corresponding cylindrical spring for individual length compensation to  $l_1$  installation length. UG943 can also be used as a multiple seal in tandem or in a back-to-back arrangement. The entire UG943 series is available in metric and inch sizes.

### Standards

EN 12756  
 FDA

### Materials

Seal face: Carbon graphite antimony impregnated (A), Carbon graphite resin impregnated (B), Silicon carbide (Q1)  
 Seat: Silicon carbide (Q1, Q2), Aluminium oxide (V)  
 Elastomer: NBR (P), EPDM (E), FKM (V), HNBR (X4)  
 Metal parts: CrNiMo steel (G)

### Stationary Seats

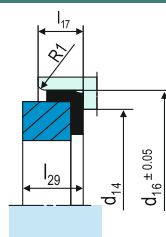

**G50**  
Euro standard

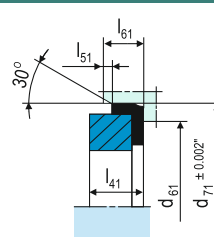

**G55**  
US standard

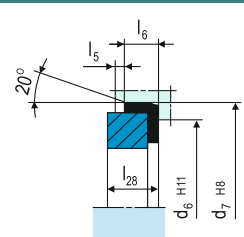

**G60**  
EN 12756

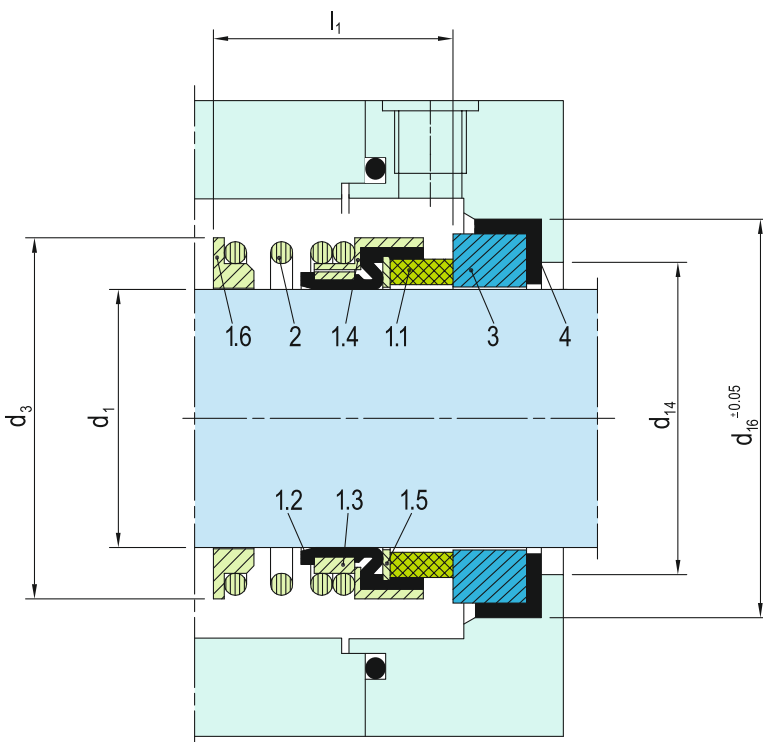

Note: The item numbers as depicted above are based on our technical experience and knowledge and are placed in the chronological order of their assembly procedure.

Item	Description
1.1	Seal face
1.2	Bellows
1.3	Driver collar
1.4	"L" ring (spring collar)
1.5	Washer
1.6	Corner Ring
2	Spring
3	Seat
4	O-ring
<b>DIN 24250</b>	

## Dimensional Data

### Dimensions in inch

d <sub>1</sub>	d <sub>3</sub>	d <sub>6</sub>	d <sub>7</sub>	d <sub>14</sub>	d <sub>16</sub>	d <sub>61</sub>	d <sub>71</sub>	l <sub>1</sub>	l <sub>5</sub>	l <sub>6</sub>	l <sub>17</sub>	l <sub>28</sub>	l <sub>29</sub>	l <sub>41</sub>	l <sub>51</sub>	l <sub>61</sub>
0.375	0.787	0.669	0.827	0.433	0.969	0.625	0.875	0.941	0.059	0.157	0.295	0.260	0.354	0.313	0.050	0.250
0.500	0.866	0.748	0.906	0.531	1.094	0.750	1.000	0.941	0.059	0.157	0.295	0.260	0.354	0.313	0.050	0.250
0.625	1.024	0.906	1.063	0.669	1.219	0.937	1.250	1.039	0.059	0.157	0.354	0.260	0.413	0.406	0.050	0.344
0.750	1.339	1.142	1.378	0.846	1.406	1.062	1.375	1.083	0.079	0.197	0.354	0.295	0.413	0.406	0.050	0.344
0.875	1.417	1.220	1.457	0.906	1.469	1.187	1.500	1.083	0.079	0.197	0.354	0.295	0.413	0.406	0.050	0.344
1.000	1.535	1.339	1.575	1.043	1.594	1.312	1.625	1.181	0.079	0.197	0.354	0.295	0.413	0.437	0.050	0.375
1.125	1.654	1.457	1.693	1.161	1.876	1.437	1.750	1.280	0.079	0.197	0.413	0.295	0.472	0.437	0.050	0.375
1.250	1.811	1.654	1.890	1.280	2.000	1.563	1.875	1.280	0.079	0.197	0.413	0.295	0.472	0.437	0.050	0.375
1.375	1.929	1.732	1.969	1.437	2.126	1.687	2.000	1.280	0.079	0.197	0.413	0.295	0.472	0.437	0.050	0.375
1.500	2.126	1.929	2.205	1.555	2.250	1.813	2.125	1.339	0.079	0.236	0.413	0.354	0.472	0.437	0.050	0.375
1.625	2.205	2.008	2.283	1.673	2.376	2.000	2.375	1.339	0.079	0.236	0.413	0.354	0.472	0.500	0.050	0.437
1.750	2.402	2.205	2.480	1.811	2.500	2.125	2.500	1.339	0.079	0.236	0.413	0.354	0.472	0.500	0.050	0.437
1.875	2.520	2.323	2.598	1.929	2.626	2.250	2.625	1.339	0.079	0.236	0.413	0.354	0.472	0.500	0.050	0.437
2.000	2.598	2.441	2.756	2.047	2.750	2.375	2.750	1.358	0.098	0.236	0.472	0.374	0.531	0.500	0.050	0.437
2.125	2.717	2.559	2.874	2.185	2.876	2.375	3.000	1.358	0.098	0.236	0.472	0.433	0.531	0.562	0.050	0.500
2.250	3.071	2.756	3.071	2.421	3.126	2.437	3.125	1.555	0.098	0.236	0.472	0.433	0.531	0.562	0.050	0.500
2.375	3.150	2.835	3.150	2.421	3.126	2.563	3.250	1.555	0.098	0.236	0.472	0.433	0.531	0.562	0.050	0.500
2.500	3.268	2.953	3.268	2.559	3.250	2.687	3.375	1.465	0.098	0.236	0.472	0.433	0.531	0.562	0.050	0.500
2.625	3.465	3.189	3.543	2.795	3.750	2.812	3.375	1.465	0.098	0.276	0.571	0.445	0.630	0.625	0.100	0.562
2.750	3.543	3.268	3.622	2.795	3.750	2.937	3.500	1.760	0.098	0.276	0.571	0.445	0.630	0.625	0.100	0.562
2.875	-	-	-	-	-	3.062	3.750	1.760	-	-	-	-	-	0.625	0.100	0.562
3.000	3.898	3.465	3.819	3.051	4.000	3.187	3.875	1.760	0.098	0.276	0.571	0.445	0.630	0.625	0.100	0.562
3.125	4.094	3.740	4.134	3.307	4.500	3.312	4.000	1.744	0.118	0.276	0.728	0.472	0.787	0.781	0.100	0.656
3.250	-	-	-	-	-	3.437	4.125	1.744	-	-	-	-	-	0.781	0.100	0.656
3.375	4.291	3.937	4.331	3.425	4.626	3.562	4.250	1.744	0.118	0.276	0.728	0.551	0.787	0.781	0.100	0.656
3.500	4.488	4.134	4.528	3.681	4.876	3.687	4.375	1.941	0.118	0.276	0.728	0.551	0.787	0.781	0.100	0.656
3.625	-	-	-	-	-	3.812	4.500	1.941	-	-	-	-	-	0.781	0.100	0.656
3.750	4.685	4.331	4.724	3.799	5.000	3.937	4.625	1.941	0.118	0.276	0.728	0.551	0.787	0.781	0.100	0.656
3.875	-	-	-	-	-	4.062	4.750	1.941	-	-	-	-	-	0.781	0.100	0.656
4.000	4.882	4.528	4.921	4.055	5.250	4.187	4.875	1.941	0.118	0.276	0.728	0.551	0.787	0.781	0.100	0.656

### Dimensions in millimeter

d <sub>1</sub>	d <sub>3</sub>	d <sub>6</sub>	d <sub>7</sub>	d <sub>14</sub>	d <sub>16</sub>	d <sub>61</sub>	d <sub>71</sub>	l <sub>1</sub>	l <sub>5</sub>	l <sub>6</sub>	l <sub>17</sub>	l <sub>28</sub>	l <sub>29</sub>	l <sub>41</sub>	l <sub>51</sub>	l <sub>61</sub>
10	20	17	21	11.0	24.60	15.88	22.23	23.9	1.5	4	7.5	6.6	9.0	7.95	1.27	6.35
12	22	19	23	13.5	27.80	19.05	25.40	23.9	1.5	4	7.5	6.6	9.0	7.95	1.27	6.35
14	24	21	25	17.0	30.95	-	-	26.4	1.5	4	9.0	6.6	10.5	-	-	-
15	-	-	-	17.0	30.95	-	-	-	-	-	9.0	-	10.5	-	-	-
16	26	23	27	17.0	30.95	23.80	31.75	26.4	1.5	4	9.0	6.6	10.5	10.31	1.27	8.74
18	32	27	33	20.0	34.15	-	-	27.5	2.0	5	9.0	7.5	10.5	-	-	-
20	34	29	35	21.5	35.70	26.97	34.93	27.5	2.0	5	9.0	7.5	10.5	10.31	1.27	8.74
22	36	31	37	23.0	37.30	30.15	38.10	27.5	2.0	5	9.0	7.5	10.5	10.31	1.27	8.74
24	38	33	39	26.5	40.50	-	-	30.0	2.0	5	9.0	7.5	10.5	-	-	-
25	39	34	40	26.5	40.50	33.32	41.28	30.0	2.0	5	9.0	7.5	10.5	11.10	1.27	9.53
28	42	37	43	29.5	47.65	36.50	44.45	32.5	2.0	5	10.5	7.5	12.0	11.10	1.27	9.53
30	44	39	45	32.5	50.80	-	-	32.5	2.0	5	10.5	7.5	12.0	-	-	-
32	46	42	48	32.5	50.80	39.70	47.63	32.5	2.0	5	10.5	7.5	12.0	11.10	1.27	9.53
33	47	42	48	36.5	54.00	39.70	47.63	32.5	2.0	5	10.5	7.5	12.0	11.10	1.27	9.53
35	49	44	50	36.5	54.00	42.85	50.80	32.5	2.0	5	10.5	7.5	12.0	11.10	1.27	9.53
38	54	49	56	39.5	57.15	46.05	53.98	34.0	2.0	6	10.5	9.0	12.0	11.10	1.27	9.53
40	56	51	58	42.5	60.35	50.80	60.33	34.0	2.0	6	10.5	9.0	12.0	12.70	1.27	11.10
43	59	54	61	46.0	63.50	-	-	34.0	2.0	6	10.5	9.0	12.0	-	-	-
45	61	56	63	46.0	63.50	53.98	63.50	34.0	2.0	6	10.5	9.0	12.0	12.70	1.27	11.10
48	64	59	66	49.0	66.70	57.15	66.68	34.0	2.0	6	10.5	9.0	12.0	12.70	1.27	11.10
50	66	62	70	52.0	69.85	60.33	69.85	34.5	2.5	6	12.0	9.5	13.5	12.70	1.27	11.10
53	69	65	73	55.5	73.05	60.33	76.20	34.5	2.5	6	12.0	11.0	13.5	14.27	1.27	12.70
55	71	67	75	58.5	76.20	-	-	34.5	2.5	6	12.0	11.0	13.5	-	-	-
58	78	70	78	61.5	79.40	61.90	79.38	39.5	2.5	6	12.0	11.0	13.5	14.27	1.27	12.70
60	80	72	80	61.5	79.40	65.10	82.55	39.5	2.5	6	12.0	11.0	13.5	14.27	1.27	12.70
63	83	75	83	65.0	82.55	68.25	85.73	39.5	2.5	6	12.0	11.0	13.5	14.27	1.27	12.70
65	85	77	85	68.0	92.10	-	-	39.5	2.5	6	14.5	11.0	16.0	-	-	-
68	88	81	90	71.0	95.25	71.42	85.73	37.2	2.5	7	14.5	11.3	16.0	15.88	2.54	14.27
70	90	83	92	71.0	95.25	74.60	88.90	44.7	2.5	7	14.5	11.3	16.0	15.88	2.54	14.27
75	99	88	97	77.5	101.60	80.95	98.43	44.7	2.5	7	14.5	11.3	16.0	15.88	2.54	14.27
80	104	95	105	84.0	114.30	84.12	101.60	44.3	3.0	7	18.5	12.0	20.0	19.84	2.54	16.66
85	109	100	110	87.0	117.50	90.47	107.95	44.3	3.0	7	18.5	14.0	20.0	19.84	2.54	16.66
90	114	105	115	93.5	123.85	93.65	111.13	49.3	3.0	7	18.5	14.0	20.0	19.84	2.54	16.66
95	119	110	120	96.5	127.00	100.00	117.48	49.3	3.0	7	18.5	14.0	20.0	19.84	2.54	16.66
100	124	115	125	103.0	133.35	106.35	123.83	49.3	3.0	7	18.5	14.0	20.0	19.84	2.54	16.66

**Note: Additional technical & dimensional information will be provided on request**

The specifications, drawings, images etc included in this catalogue are intended to be generic and must be interpreted as equivalent or functionally equivalent, more specifically the performance capabilities mentioned in this catalogue is based on optimum values, however the performance of the product is dependent on size, material of construction, media, pressure, temperature, sliding velocity etc and it shall vary from size to size or application to application. Customers are requested to consult with Sealmatic before employing the product from this catalogue for any application.



### Product Description

1. Single seal configuration
2. Unbalanced design
3. Independent of direction of rotation
4. For plain shafts
5. Rotary elastomer bellows design

### Technical Features

1. Low cost seal solution
2. Suitable for mild sterile applications
3. No damage to the shaft
4. Can be employed for low solids content
5. Multifaceted application usage

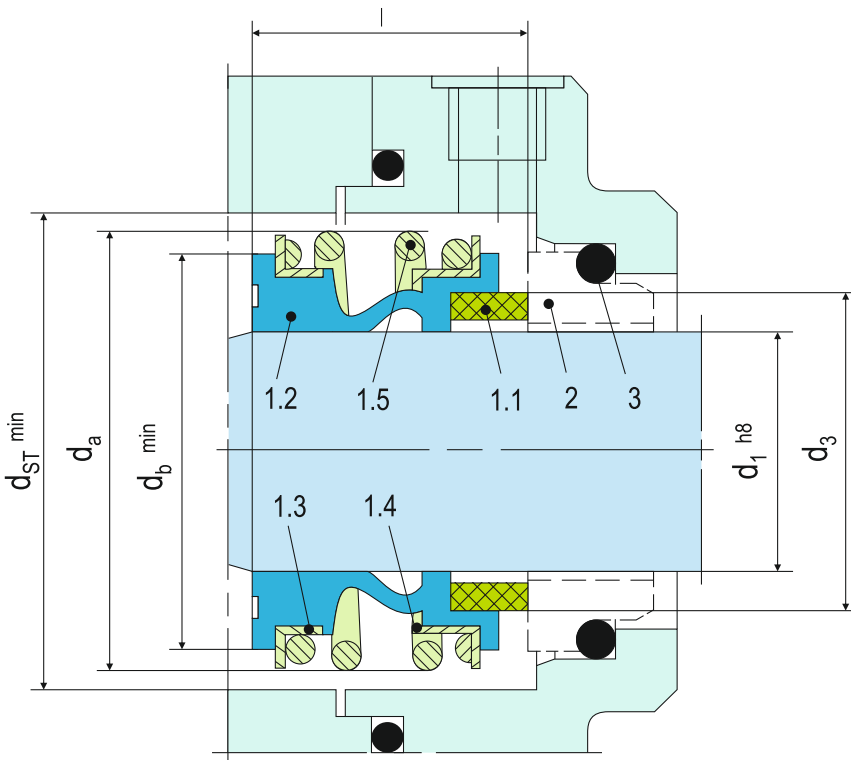

Note: The item numbers as depicted above are based on our technical experience and knowledge and are placed in the chronological order of their assembly procedure.

### Typical Industrial Applications

Chemical industry  
 Food processing industry  
 Pulp, paper & Latex  
 Water, waste water and mild slurries  
 Chemical standard pumps  
 Helical screw pumps  
 Submersible pumps

### Performance Capabilities

Sizes:  $d_1$  = Up to 100 mm (Up to 4.000")  
 Pressure:  $p_1$  = 16 bar (230 PSI)  
 vacuum: 0.5 bar (7.25 PSI), up to 1 bar (14.5 PSI) with seat locking  
 Temperature:  $t$  = -20°C...+140°C (-4°F...+284°F)  
 Speed: = 10 m/s (33 ft/s)  
 Permissible axial movement:  $\pm 2.0$  mm

### Notes

The UG100 can also be used as a multiple seal in tandem or in a back-to-back arrangement. Installation proposals can be supplied on request.

Dimension adaptations for specific conditions, e.g. shaft in inches or special seat dimensions are available on request.

### Standards

EN 12756

### Materials

Seal face: Carbon graphite antimony impregnated (A), Carbon graphite resin impregnated (B), Silicon carbide (Q1), Tungsten carbide (U3)  
 Seat: Silicon carbide (Q1, Q2), Tungsten carbide (U3), Special cast CrMo steel (S), Aluminium oxide (V)  
 Elastomer: NBR (P), EPDM (E), FKM (V),  
 Metal parts: CrNiMo steel (G), Hastelloy® C-4 (M)

Item	Part no.	Description
1.1	472	Seal face
1.2	481	Bellows
1.3	484.2	L-ring (spring collar)
1.4	484.1	L-ring (spring collar)

DIN 24250

Item	Part no.	Description
1.5	477	Spring
2	475	Seat
3	412	O-ring or cup rubber

DIN 24250

### Stationary Seats

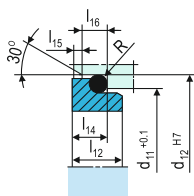

G4

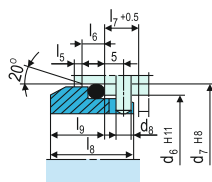

G9  
EN 12756

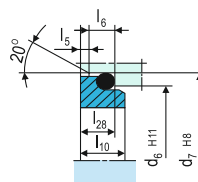

G6  
EN 12756

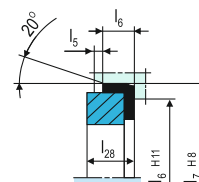

G60  
EN 12756

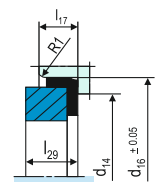

G50  
Euro standard



## Design Variations

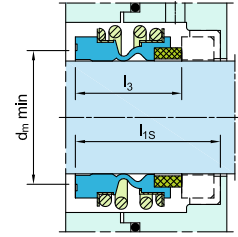
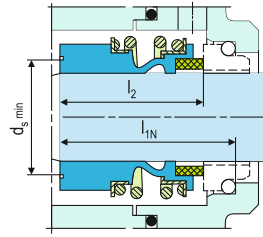
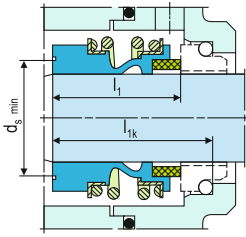

### UG120

Dimensions, items and designations same as for UG100, but with an extended bellows tail to achieve the fitting length  $l_{1k}$  according to EN 12756 in combination with seat G6 or G60 ( $d_a$  exceeds EN 12756).

### UG130

Dimensions, items and designations same as for UG100, but with an extended bellows tail to achieve the fitting length  $l_{1N}$  according to EN 12756 in combination with seat G6 or G60 ( $d_a$  exceeds EN 12756).

### UG100S20

Dimensions, items and designations same as for UG100, but with an extended bellows tail to achieve the special fitting length  $l_{1S}$  in combination with seat.

## Dimensional Data

### Dimensions in millimeter

d <sub>1</sub>	d <sub>3</sub>	d <sub>6</sub>	d <sub>7</sub>	d <sub>8</sub>	d <sub>11</sub>	d <sub>12</sub>	d <sub>14</sub>	d <sub>16</sub>	d <sub>a</sub>	d <sub>b</sub> <sup>*)</sup>	d <sub>m</sub> <sup>*)</sup>	d <sub>s</sub> <sup>*)</sup>	d <sub>ST</sub>	l	l <sub>1</sub>	l <sub>1k</sub>	l <sub>1N</sub>	l <sub>1S</sub>	l <sub>2</sub>	l <sub>3</sub>	l <sub>5</sub>	l <sub>6</sub>	l <sub>7</sub>	l <sub>8</sub>	l <sub>9</sub>	l <sub>10</sub>	l <sub>12</sub>	l <sub>14</sub>	l <sub>15</sub>	l <sub>16</sub>	l <sub>17</sub>	l <sub>28</sub>	l <sub>29</sub>	R
10	15.7	17	21	3	15.5	19.2	11.0	24.60	22.5	20.5	18	18	24	14.5	25.9	32.5	40	34.0	33.4	25	1.5	4	8.5	17.5	10.0	7.5	7.5	6.6	1.2	3.8	7.5	6.6	9.0	1.2
12	17.7	19	23	3	17.5	21.6	13.5	27.80	25.0	22.5	20	20	26	15.0	25.9	32.5	40	34.0	33.4	25	1.5	4	8.5	17.5	10.0	7.5	6.5	5.6	1.2	3.8	7.5	6.6	9.0	1.2
14	19.7	21	25	3	20.5	24.6	17.0	30.95	28.5	26.5	22	22	30	17.0	28.4	35.0	40	35.5	33.4	25	1.5	4	8.5	17.5	10.0	7.5	6.5	5.6	1.2	3.8	9.0	6.6	10.5	1.2
15	20.8	-	-	-	20.5	24.6	17.0	30.95	28.5	26.5	22	22	30	17.0	28.4	-	-	35.5	33.4	25	-	-	-	-	-	7.5	6.6	1.2	3.8	9.0	-	10.5	1.2	
16	21.0	23	27	3	22.0	28.0	17.0	30.95	28.5	26.5	22	22	30	17.0	28.4	35.0	40	35.5	33.4	25	1.5	4	8.5	17.5	10.0	7.5	8.5	7.5	1.5	5.0	9.0	6.6	10.5	1.5
18	23.7	27	33	3	24.0	30.0	20.0	34.15	32.0	29.0	29	26	33	19.5	30.0	37.5	45	35.5	37.5	25	2.0	5	9.0	19.5	11.5	8.5	9.0	8.0	1.5	5.0	9.0	7.5	10.5	1.5
19	26.7	-	-	-	-	-	20.0	34.15	37.0	33.0	33	28	38	21.5	30.0	-	-	35.5	37.5	25	-	-	-	-	-	-	-	-	-	-	9.0	-	10.5	-
20	26.7	29	35	3	29.5	35.0	21.5	35.70	37.0	33.0	33	28	38	21.5	30.0	37.5	45	35.5	37.5	25	2.0	5	9.0	19.5	11.5	8.5	8.5	7.5	1.5	5.0	9.0	7.5	10.5	1.5
22	27.7	31	37	3	29.5	35.0	23.0	37.30	37.0	33.0	33	28	38	21.5	30.0	37.5	45	35.5	37.5	25	2.0	5	9.0	19.5	11.5	8.5	8.5	7.5	1.5	5.0	9.0	7.5	10.5	1.5
24	31.2	33	39	3	32.0	38.0	26.5	40.50	42.5	38.0	38	32	44	22.5	32.5	40.0	50	35.5	42.5	25	2.0	5	9.0	19.5	11.5	8.5	8.5	7.5	1.5	5.0	9.0	7.5	10.5	1.5
25	31.2	34	40	3	32.0	38.0	26.5	40.50	42.5	38.0	38	32	44	23.0	32.5	40.0	50	35.5	42.5	25	2.0	5	9.0	19.5	11.5	8.5	8.5	7.5	1.5	5.0	9.0	7.5	10.5	1.5
28	35.0	37	43	3	36.0	42.0	29.5	47.65	49.0	44.0	37	37	50	26.5	35.0	42.5	50	45.0	42.5	33	2.0	5	9.0	19.5	11.5	8.5	10.0	9.0	1.5	5.0	10.5	7.5	12.0	1.5
30	37.0	39	45	3	39.2	45.0	32.5	50.80	49.0	44.0	37	37	50	26.5	35.0	42.5	50	45.0	42.5	33	2.0	5	9.0	19.5	11.5	8.5	11.5	10.5	1.5	5.0	10.5	7.5	12.0	1.5
32	40.2	42	48	3	42.2	48.0	32.5	50.80	53.5	46.0	41	41	55	27.5	35.0	42.5	55	45.0	47.5	33	2.0	5	9.0	19.5	11.5	8.5	11.5	10.5	1.5	5.0	10.5	7.5	12.0	1.5
33	40.2	42	48	3	44.2	50.0	36.5	54.00	53.5	46.0	41	41	55	27.5	35.0	42.5	55	45.0	47.5	33	2.0	5	9.0	19.5	11.5	8.5	12.0	11.0	1.5	5.0	10.5	7.5	12.0	1.5
35	43.2	44	50	3	46.2	52.0	36.5	54.00	57.0	50.0	44	44	59	28.5	35.0	42.5	55	45.0	47.5	33	2.0	5	9.0	19.5	11.5	8.5	12.0	11.0	1.5	5.0	10.5	7.5	12.0	1.5
38	46.2	49	56	4	49.2	55.0	39.5	57.15	59.0	53.0	53	47	61	30.0	36.0	45.0	55	45.0	46.0	33	2.0	6	9.0	22.0	14.0	10.0	11.3	10.3	1.5	5.0	10.5	9.0	12.0	1.5
40	48.8	51	58	4	52.2	58.0	42.5	60.35	62.0	55.0	55	49	64	30.0	36.0	45.0	55	45.0	46.0	33	2.0	6	9.0	22.0	14.0	10.0	11.8	10.8	1.5	5.0	10.5	9.0	12.0	1.5
42	51.8	-	-	-	53.3	62.0	46.0	63.50	65.5	58.0	53	53	67	30.0	36.0	-	-	53.0	51.0	41	-	-	-	-	-	-	13.2	12.0	2.0	6.0	10.5	-	12.0	2.5
43	51.8	54	61	4	53.3	62.0	46.0	63.50	65.5	58.0	53	53	67	30.0	36.0	45.0	60	53.0	51.0	41	2.0	6	9.0	22.0	14.0	10.0	13.2	12.0	2.0	6.0	10.5	9.0	12.0	2.5
45	53.8	56	63	4	55.3	64.0	46.0	63.50	68.0	60.0	55	55	70	30.0	36.0	45.0	60	53.0	51.0	41	2.0	6	9.0	22.0	14.0	10.0	12.8	11.6	2.0	6.0	10.5	9.0	12.0	2.5
48	56.8	59	66	4	59.7	68.4	49.0	66.70	70.5	63.0	58	58	74	30.5	36.0	45.0	60	53.0	51.0	41	2.0	6	9.0	22.0	14.0	10.0	12.8	11.6	2.0	6.0	10.5	9.0	12.0	2.5
50	58.8	62	70	4	60.8	69.3	52.0	69.85	74.0	65.0	60	60	77	30.5	38.0	47.5	60	54.5	50.5	41	2.5	6	9.0	23.0	15.0	10.5	12.8	11.6	2.0	6.0	12.0	9.5	13.5	2.5
53	62.2	65	73	4	63.8	72.3	55.5	73.05	78.5	70.0	63	63	81	33.0	36.5	47.5	70	54.5	59.0	41	2.5	6	9.0	23.0	15.0	12.0	13.5	12.3	2.0	6.0	12.0	11.0	13.5	2.5
55	64.2	67	75	4	66.5	75.4	58.5	76.20	81.0	72.0	65	65	83	35.0	36.5	47.5	70	54.5	59.0	41	2.5	6	9.0	23.0	15.0	12.0	14.5	13.3	2.0	6.0	12.0	11.0	13.5	2.5
58	67.2	70	78	4	69.5	78.4	61.5	79.40	85.5	75.0	68	68	88	37.0	41.5	52.5	70	54.5	59.0	41	2.5	6	9.0	23.0	15.0	12.0	14.5	13.3	2.0	6.0	12.0	11.0	13.5	2.5
60	70.0	72	80	4	71.5	80.4	61.5	79.40	88.5	79.0	70	70	91	38.0	41.5	52.5	70	54.5	59.0	41	2.5	6	9.0	23.0	15.0	12.0	14.5	13.3	2.0	6.0	12.0	11.0	13.5	2.5
65	75.0	77	85	4	76.5	85.4	68.0	92.10	93.5	84.0	77	77	96	40.0	41.5	52.5	80	65.0	69.0	49	2.5	6	9.0	23.0	15.0	12.0	14.2	13.0	2.0	6.0	14.5	11.0	16.0	2.5
68	78.0	81	90	4	82.7	91.5	71.0	95.25	96.5	88.0	80	80	100	40.0	41.2	52.5	80	65.0	68.7	49	2.5	7	9.0	26.0	18.0	12.5	14.9	13.7	2.0	6.0	14.5	11.3	16.0	2.5
70	80.0	83	92	4	83.0	92.0	71.0	95.25	99.5	90.0	82	82	103	40.0	48.7	60.0	80	65.0	68.7	49	2.5	7	9.0	26.0	18.0	12.5	14.2	13.0	2.0	6.0	14.5	11.3	16.0	2.5
75	85.5	88	97	4	90.2	99.0	77.5	101.60	107.0	95.0	87	87	110	40.0	48.7	60.0	80	68.0	68.7	52	2.5	7	9.0	26.0	18.0	12.5	15.2	14.0	2.0	6.0	14.5	11.3	16.0	2.5
80	90.5	95	105	4	95.2	104.0	84.0	114.30	112.0	100.0	92	92	116	40.0	48.0	60.0	90	76.0	78.0	56	3.0	7	9.0	26.2	18.2	13.0	16.2	15.0	2.0	6.0	18.5	12.0	20.0	2.5
85	96.0	100	110	4	100.2	109.0	87.0	117.50	120.0	107.0	97	97	124	41.0	46.0	60.0	90	76.0	76.0	56	3.0	7	9.0	26.2	18.2	15.0	16.0	14.8	2.0	6.0	18.5	14.0	20.0	2.5
90	102.0	105	115	4	105.2	114.0	93.5	123.85	127.0	114.0	104	104	131	45.0	51.0	65.0	90	79.0	76.0	59	3.0	7	9.0	26.2	18.2	15.0	16.0	14.8	2.0	6.0	18.5	14.0	20.0	2.5
95	107.0	110	120	4	111.6	120.3	96.5	127.00	132.0	119.0	109	109	136	46.0	51.0	65.0	90	79.0	76.0	59	3.0	7	9.0	25.2	17.2	15.0	17.0	15.8	2.0	6.0	18.5	14.0	20.0	2.5
100	112.0	115	125	4	114.5	123.3	103.0	133.35	137.0	124.0	114	114	140	47.0	51.0	65.0	90	82.0	76.0	62	3.0	7	9.0	25.2	17.2	15.0	17.0	15.8	2.0	6.0	18.5	14.0	20.0	2.5

\*) minimum diameter of the mating collar.  
inch size available from size 0.375 to 4.000

Note: Additional technical & dimensional information will be provided on request.

The specifications, drawings, images etc included in this catalogue are intended to be generic and must be interpreted as equivalent or functionally equivalent, more specifically the performance capabilities mentioned in this catalogue is based on optimum values, however the performance of the product is dependent on size, material of construction, media, pressure, temperature, sliding velocity etc and it shall vary from size to size or application to application. Customers are requested to consult with Sealmatic before employing the product from this catalogue for any application.



### Product Description

1. Single seal configuration
2. Balanced design
3. Independent of direction of rotation
4. For plain shafts
5. Rotary metal bellows design

### Technical Features

1. Suitable for high temperature application
2. No dynamically loaded O-ring
3. Pumping screw for media with higher viscosity also available
4. Short installation length possible
5. Rugged design for long operating life
6. Bellows design efficiently ensure self-cleaning

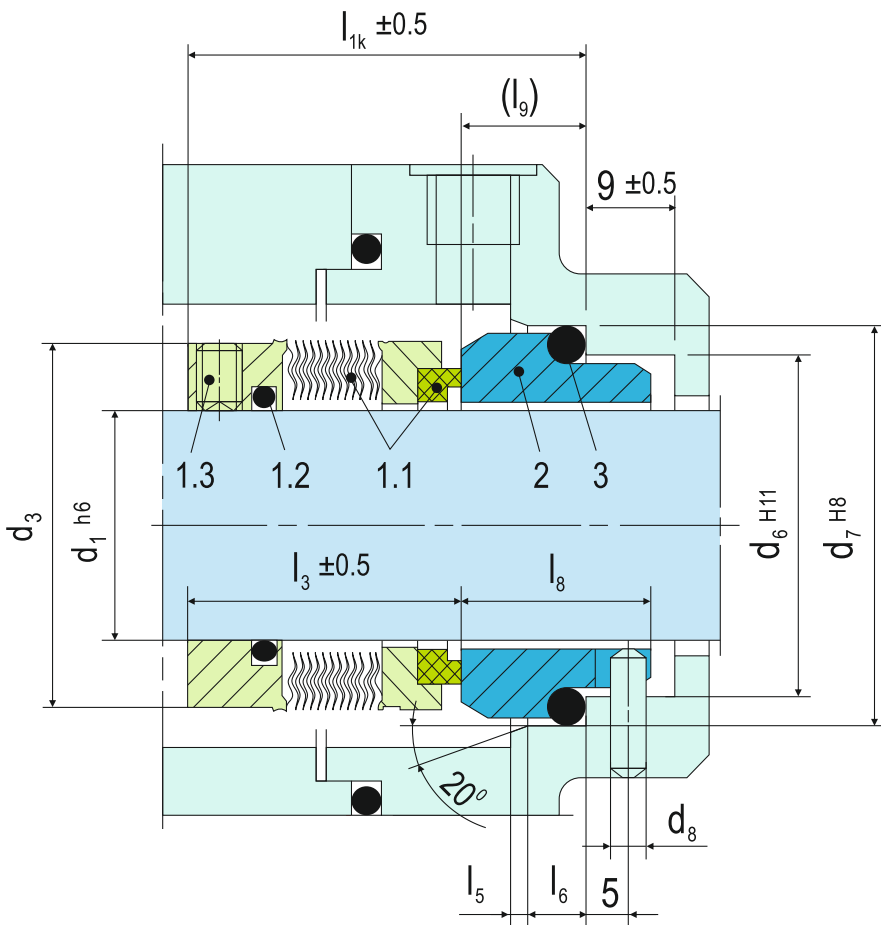

Note: The item numbers as depicted above are based on our technical experience and knowledge and are placed in the chronological order of their assembly procedure.

Item	Part no.	Description
1.1	472/481	Seal face with bellows unit
1.2	412.1	O-ring
1.3	904	Set Screw
2	475	Seat (G9)
3	412.2	O-ring

**DIN 24250**

### Typical Industrial Applications

Chemical industry  
Cold media  
Highly viscous media  
Hot media  
Power plant technology  
Refining technology

### Standards

EN 12756

### Performance Capabilities

Sizes:  $d_1 =$  Upto 100 mm (Upto 4.000")  
Externally pressurized:  
 $p_1 = \dots$  25 bar (363 PSI)  
Internally pressurized:  
 $p_1 < 120^\circ\text{C}$  (248 °F) 10 bar (145 PSI)  
 $p_1 < 220^\circ\text{C}$  (428 °F) 5 bar (72 PSI)  
Temperature:  $t = -40^\circ\text{C} \dots +220^\circ\text{C}$  (-40°F...+428°F)  
Stationary seat lock necessary.  
Speed = 20 m/s (66 ft/s)

### Materials

Seal face: Carbon graphite antimony impregnated (A), Silicon carbide (Q12)  
Seat: Silicon carbide (Q1)  
Bellows: Inconel® 718 hardened (M6), Hastelloy® C-276 (M5)  
Metal parts: CrNiMo steel (G), Duplex (G1), Hastelloy® C-4 (M)

### Stationary Seats

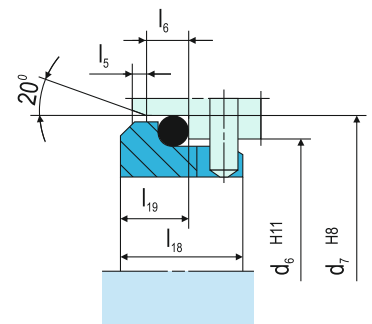

### G16

( $l_{1k}$  shorter than specified by EN 12756)

## Design Variations

### UFL900N

Shaft diameter:  $d_7$  = Upto 100 mm (Upto 4.000")  
 Internally pressurized:  $p_1$  = ... 16 bar (232 PSI),  
 stationary seat lock necessary.  
 Externally pressurized:  $p_1$  = 10 bar (145 PSI)  
 Temperature:  $t$  = -40 °C... +220 °C (-40 °F...+428 °F)  
 Speed = 20 m/s (66 ft/s)

### UFL850P / UFL900P

Version with pumping ring. Dependent on direction of rotation. Can be retrofitted.

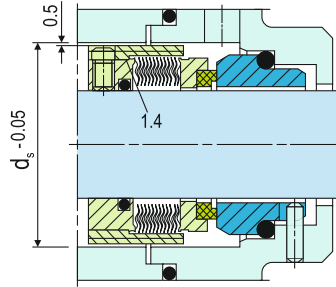

### UFL850F

Dimensions, items and description as for UFL850N, but with pumping screw (item no. 1.4).  
 Dependent on direction of rotation. The pumping screw can be retrofitted.

## Dimensional Data

### Dimensions in millimeter

$d_1$	$d_3$	$d_6$	$d_7$	$d_8$	$d_s$	$l_{1K}$	$l_3$	$l_5$	$l_6$	$l_8$	$l_9$	$l_{18}$	$l_{19}$	$b$	$s$
16	30	23	27	3	38	42.5*)	32.5	1.5	4	17.5	10	-	-	1.6	9.0
18	32	27	33	3	39	42	30.5	2	5	14	11.5	15	7.0	1.6	10.0
20	33.5	29	35	3	41	42	30.5	2	5	14	11.5	15	7.0	1.6	10.0
22	36.5	31	37	3	44	42	30.5	2	5	14	11.5	15	7.0	1.6	10.0
24	39	33	39	3	47	40	28.5	2	5	19.5	11.5	15	7.0	1.6	8.2
25	39.6	34	40	3	48	40	28.5	2	5	19.5	11.5	15	7.0	1.6	8.5
28	42.8	37	43	3	51	42.5	31	2	5	19.5	11.5	15	7.0	1.6	9.0
30	45	39	45	3	53	42.5	31	2	5	19.5	11.5	15	7.0	1.6	8.5
32	46	42	48	3	55	42.5	31	2	5	19.5	11.5	15	7.0	1.6	9.2
33	48	42	48	3	56	42.5	31	2	5	19.5	11.5	15	7.0	1.6	9.2
35	49.2	44	50	3	58	42.5	31	2	5	19.5	11.5	15	7.0	1.6	9.5
38	52.3	49	56	4	61	45	31	2	6	22	14	16	8.0	1.6	9.2
40	55.5	51	58	4	64	45	31	2	6	22	14	16	8.0	1.6	9.2
43	57.5	54	61	4	67	45	31	2	6	22	14	16	8.0	1.6	9.2
45	58.7	56	63	4	69	45	31	2	6	22	14	16	8.0	1.6	9.5
48	61.9	59	66	4	72	45	31	2	6	22	14	16	8.0	1.6	9.2
50	65	62	70	4	74	47.5	32.5	2.5	6	23	15	17	9.5	1.6	10.5
53	68.2	65	73	4	77	47.5	32.5	2.5	6	23	15	17	9.5	1.6	10.5
55	70	67	75	4	80	47.5	32.5	2.5	6	23	15	17	9.5	1.6	10.0
58	71.7	70	78	4	83	52.5	37.5	2.5	6	23	15	18	10.5	3.0	14.0
60	74.6	72	80	4	85	52.5	37.5	2.5	6	23	15	18	10.5	3.0	14.0
63	79	75	83	4	88	52.5	37.5	2.5	6	23	15	18	10.5	3.0	14.0
65	84.1	77	85	4	95	52.5	37.5	2.5	6	23	15	18	10.5	3.0	14.0
68	87.3	81	90	4	96	52.5	34.5	2.5	7	26	18	18.5	11.0	1.6	10.0
70	87.3	83	92	4	96	60	42	2.5	7	26	18	19	11.5	3.0	17.0
75	95	88	97	4	104	60	42	2.5	7	26	18	19	11.5	3.0	16.0
80	98.4	95	105	4	109	60	41.8	3	7	26.2	18.2	19	11.5	3.0	16.0
85	104.7	100	110	4	114	60	41.8	3	7	26.2	18.2	19	11.5	3.0	16.0
90	111	105	115	4	119	65	46.8	3	7	26.2	18.2	20.5	13.0	3.0	21.0
95	114	110	120	4	124	65	47.8	3	7	25.2	17.2	20.5	13.0	3.0	21.0
100	117.4	115	125	4	129	65	47.8	3	7	25.2	17.2	20.5	13.0	3.0	20.0

\*) Installation length is longer than  $l_{1K}$ , specified by EN 12756  
 inch size available from size 0.625 to 4.000

Note: Additional technical & dimensional information will be provided on request.

The specifications, drawings, images etc included in this catalogue are intended to be generic and must be interpreted as equivalent or functionally equivalent, more specifically the performance capabilities mentioned in this catalogue is based on optimum values, however the performance of the product is dependent on size, material of construction, media, pressure, temperature, sliding velocity etc and it shall vary from size to size or application to application. Customers are requested to consult with Sealmatic before employing the product from this catalogue for any application.



### Product Description

1. Single seal configuration
2. Balanced design
3. Independent of direction of rotation
4. Stationary metal bellows design

### Technical Features

1. Suitable for high temperature application
2. Can handle high sliding velocities
3. No elastomer secondary seals
4. Rugged design for long operating life
5. Bellows design efficiently ensure self-cleaning

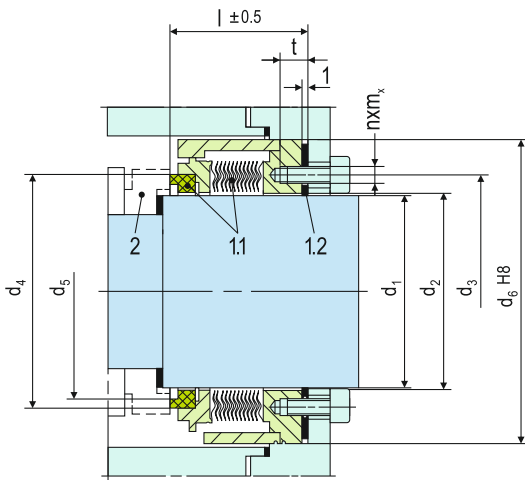

Note: The item numbers as depicted above are based on our technical experience and knowledge and are placed in the chronological order of their assembly procedure.

Item	Part no.	Description
1.1	472/481	Seal face with bellows unit
1.2	400.1	Flat gasket
2	475	Seat
<b>DIN 24250</b>		

### Typical Industrial Applications

Chemical industry  
High sliding velocities  
Hot media  
Power plant technology  
Refining technology

### Performance Capabilities

Sizes:  $d_1$  = Upto 100 mm (Upto 4.000")  
Externally pressurized:  $p_1$  = 25 bar (363 PSI), (higher pressure possible, please inquire)  
Internally pressurized:  
 $p_1$  < 120 °C (248 °F) 10 bar (145 PSI),  
 $p_1$  < 220 °C (428 °F) 5 bar (72 PSI),  
 $p_1$  < 400 °C (752 °F) 3 bar (44 PSI)  
Stationary seat lock necessary.  
Temperature:  $t$  = -20°C...+400°C (-4°F...+752°F)  
Speed: = 50 m/s (165 ft/s)

### Materials

Bellows: Inconel® 718 (M6), Hastelloy® C-276 (M5)  
Seal face: Carbon graphite antimony impregnated (A), Silicon carbide (Q12)  
Seat: Silicon carbide (Q1), Special cast CrMo steel (S)  
Metal parts: Duplex (G1), Carpenter® 42 (T4), Hastelloy® C-4 (M)

### Design Variations

#### UFL690

Shaft diameter:  $d_1$  = Upto 100 mm (Upto 4.000"), (>100 mm on request)  
Internally pressurized:  $p_1$  = 16 bar (232 PSI), (higher pressure possible, please inquire)  
Externally pressurized:  $p_1$  = 10 bar (145 PSI), stationary seat lock necessary.  
Temperature:  $t$  = -20°C...+400°C (-4°F...+752°F)  
Speed = 50 m/s (165 ft/s)

### Dimensional Data

#### Dimensions in millimeter

d	d <sub>1</sub>	d <sub>2</sub>	d <sub>3</sub>	d <sub>4</sub>	d <sub>5</sub>	d <sub>6</sub>	l	nxmx	t
19	16-19	20.5	29	30.3	25.3	45.0	33.5	4xM4	6
24	20-24	25.5	35	38.8	33.8	49.0	33.5	4xM4	6
30	25-30	31.5	40	43.6	38.6	55.0	34.5	6xM4	6
35	31-35	36.0	45	45.8	40.8	59.0	33.0	6xM4	6
40	36-40	41.0	50	51.5	46.5	65.0	30.5	6xM4	6
45	41-45	46.0	55	55.2	50.2	69.0	35.5	6xM4	6
51	46-51	52.0	63	64.7	59.7	76.5	40.5	6xM5	7
60	52-60	61.0	70	70.6	65.6	84.0	32.0	6xM5	7
70	61-70	71.0	80	82.8	76.8	95.0	38.0	6xM5	7
82	71-82	83.5	95	98.0	92.0	112.0	41.0	6xM6	7
88	83-88	89.5	100	107.7	101.7	120.0	47.0	6xM6	7
100	89-100	101.0	112	112.7	106.7	130.0	47.0	6xM6	7

inch size available from size 0.625 to 4.000

Note: Additional technical & dimensional information will be provided on request.

The specifications, drawings, images etc included in this catalogue are intended to be generic and must be interpreted as equivalent or functionally equivalent, more specifically the performance capabilities mentioned in this catalogue is based on optimum values, however the performance of the product is dependent on size, material of construction, media, pressure, temperature, sliding velocity etc and it shall vary from size to size or application to application. Customers are requested to consult with Sealmatic before employing the product from this catalogue for any application.





### Product Description

1. Single and Dual seal configuration
2. Balanced design
3. For stepped shafts
4. Rotary unit with multiple springs
5. Designed to remain in closed position in the event of buffer pressure failure
6. Can accommodate reverse pressure
7. Gas-lubricated design
8. Gas grooves design is available in V-grooves and U-grooves (independent of direction of rotation)

### Technical Features

1. Seal faces are designed to be non-contacting during operation
2. Designed for environmental protection with high efficiency
3. Due to non-contacting design there is no friction on the seal faces and there is no heat generated at the seal or in the medium
4. Trouble free operations as complex components are not required to dissipate frictional heat
5. Differential pressure not required with hard / soft material combination
6. Conforms to containment seal in accordance with API 682

### Typical Industrial Applications

Chemical industry	Gases not harmful to the environment (single seal)
Refining technology	Fans
Gases and liquids (single seals only gas)	Small steam turbines
Gases and liquids which must not get into the atmosphere (dual seal)	Blowers Roots compressors Pumps

### Performance Capabilities

Shaft diameter:  $d_1 = 28 \dots 125 \text{ mm}$  (1.10" ... 4.92")  
 Pressure:  $p_1 = 25 \text{ bar}$  (363 PSI)  
 Temperature:  $t^* = -20 \text{ }^\circ\text{C} \dots +170 \text{ }^\circ\text{C}$  (-4 °F...+338 °F)  
 Sliding velocity:  $v_g = 4 \dots 25 \text{ m/s}$  (13 ... 82 ft/s)  
 \* Depending on resistance of O-rings

### Materials

Seal face: Carbon graphite antimony impregnated (A), Silicon carbide (Q2), alternatively: Carbon graphite resin impregnated (B), Silicon carbide (Q1) Seat: Silicon carbide (Q1, Q2), Silicon carbide (Q19, Q29) with seal face in Q1 resp. Q2  
 Metal parts: CrNiMo steel (G)

### Standards

EN 12756  
 API 682 / ISO 21049

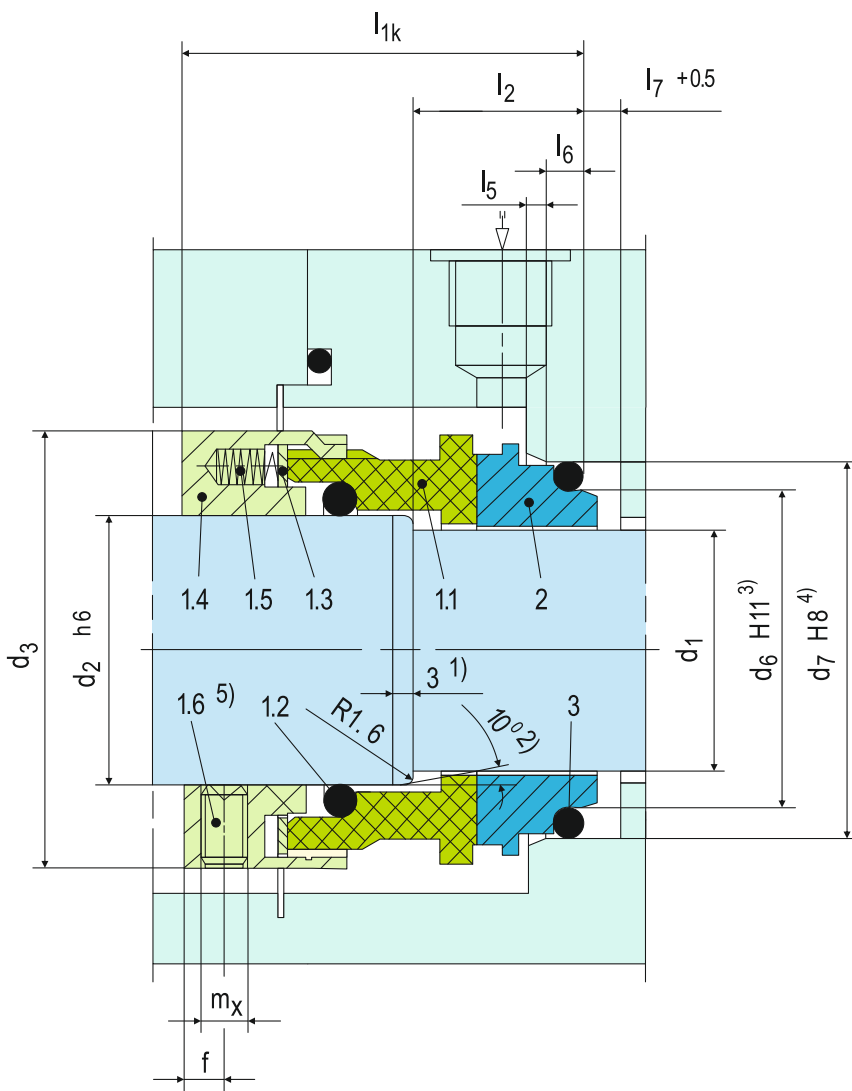

**Note:** The item numbers as depicted above are based on our technical experience and knowledge and are placed in the chronological order of their assembly procedure.

Item	Part no.	Description
1.1	472	Sliding face
1.2	412.1	O-ring
1.3	474	Thrust ring
1.4	485	Drive collar
1.5	477	Spring
1.6	904	Set screw
2	475.1	Seat
3	412.3	O-ring

### DIN 24250

<sup>1)</sup> $d_1 > 105: 2 \text{ mm} \times 30^\circ$
<sup>2)</sup> $d_1 > 105: 30^\circ$
<sup>3)</sup> $d_1 > 105: +0.1$
<sup>4)</sup> $d_1 > 105: H7$
<sup>5)</sup> $3 \times 120^\circ$

## Design Variations

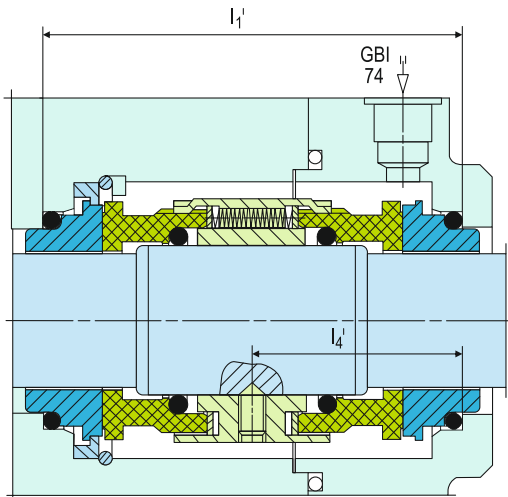

### GSPH-KD

Double seal back-to-back, buffered with gas, according to API 682 configuration 3NC-BB, Plan 74. Items, descriptions and unspecified dimensions as for GSPH-K. Pressure:  $p_1 = \dots 22 \text{ bar (319 PSI)}$ ,  $p_3 = \dots 25 \text{ bar (363 PSI)}$  (over the whole nominal diameter range, higher values on request).  
Differential pressure  $\Delta p = \text{min. } 3 \text{ bar (44 PSI)}$   
Other operating limits as GSPH-K.

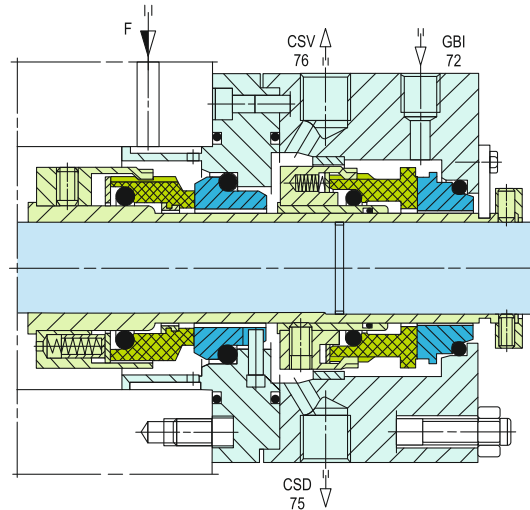

### GSPH Tandem arrangement

According to API 682  
Configuration: 2CW-CS, Plan 72, 75, 76.  
For media with a gaseous leakage. B750VN on the product side. In case of a failure, the GSPH on the atmosphere side works as a liquid seal.

## Dimensional Data

### Dimensions in millimeter

$d_1$	$d_2$	$d_3$	$d_6$	$d_7$	$l_{1K}$	$l_1'$	$l_2$	$l_4'$	$l_5$	$l_6$	$l_7$	$f$	$m_x$
28*	33	53	37.0	43.0	50.0	89	20	44.5	2.0	5	9	5	M6
30*	35	55	39.0	45.0	50.0	89	20	44.5	2.0	5	9	5	M6
32*	38	60	42.0	48.0	50.0	89	20	44.5	2.0	5	9	5	M6
33*	38	60	42.0	48.0	50.0	89	20	44.5	2.0	5	9	5	M6
35*	40	62	44.0	50.0	50.0	89	20	44.5	2.0	5	9	5	M6
38*	43	65	49.0	56.0	52.5	95	23	47.5	2.0	6	9	5	M6
40*	45	67	51.0	58.0	52.5	95	23	47.5	2.0	6	9	5	M6
43*	48	70	54.0	61.0	52.5	95	23	47.5	2.0	6	9	5	M6
45*	50	72	56.0	63.0	52.5	95	23	47.5	2.0	6	9	5	M6
48*	53	75	59.0	66.0	52.5	95	23	47.5	2.0	6	9	5	M6
50*	55	77	62.0	70.0	57.5	104	25	52.0	2.5	6	9	5	M6
53*	58	84	65.0	73.0	57.5	104	25	52.0	2.5	6	9	5	M6
55*	60	86	67.0	75.0	57.5	106	25	53.0	2.5	6	9	5	M6
58*	63	89	70.0	78.0	62.5	112	25	56.0	2.5	6	9	7	M8
60*	65	91	72.0	80.0	62.5	112	25	56.0	2.5	6	9	7	M8
63*	68	94	75.0	83.0	62.5	112	25	56.0	2.5	6	9	7	M8
65*	70	97	77.0	85.0	62.5	112	25	56.0	2.5	6	9	7	M8
70*	75	104	83.0	92.0	70.0	126	28	63.0	2.5	7	9	7	M8
75*	80	109	88.0	97.0	70.0	126	28	63.0	2.5	7	9	7	M8
80*	85	114	95.0	105.0	70.0	126	28	63.0	3.0	7	9	7	M8
85*	90	119	100.0	110.0	75.0	126	28	63.0	3.0	7	9	7	M8
90*	95	124	105.0	115.0	75.0	126	28	63.0	3.0	7	9	7	M8
95*	100	129	110.0	120.0	75.0	126	28	63.0	3.0	7	9	7	M8
100*	105	132	115.0	125.0	75.0	126	28	63.0	3.0	7	9	7	M8
105*	115	153	122.2	134.3	73.0	136	32	68.0	2.0	10	—	7	M8
110*	120	158	128.2	140.3	73.0	136	32	68.0	2.0	10	—	7	M8
115*	125	163	136.2	148.3	73.0	136	32	68.0	2.0	10	—	7	M8
120*	130	168	138.2	150.3	73.0	136	32	68.0	2.0	10	—	7	M8
125*	135	173	142.2	154.3	73.0	136	32	68.0	2.0	10	—	7	M8

\* EN 12756

inch size available from size 1.125" to 5.000"

Note: Additional technical & dimensional information will be provided on request.

The specifications, drawings, images etc included in this catalogue are intended to be generic and must be interpreted as equivalent or functionally equivalent, more specifically the performance capabilities mentioned in this catalogue is based on optimum values, however the performance of the product is dependent on size, material of construction, media, pressure, temperature, sliding velocity etc and it shall vary from size to size or application to application. Customers are requested to consult with Sealmatic before employing the product from this catalogue for any application.



### Product Description

1. Dual seal configuration
2. Balanced design
3. Cartridge construction
4. Stationary design with multiple springs
5. Seat design is rotary
6. Designed to remain in closed position in the event of buffer pressure failure,
7. Can accommodate reverse pressure
8. Gas-lubricated design
9. Gas grooves design is available in V-grooves and U-grooves (independent of direction of rotation)

### Technical Features

1. Seal faces are designed to be non-contacting during operation
2. Designed for environmental protection with high efficiency
3. Due to non-contacting design there is no friction on the seal faces and there is no heat generated at the seal or in the medium
4. Trouble free operations as complex components are not required to dissipate frictional heat

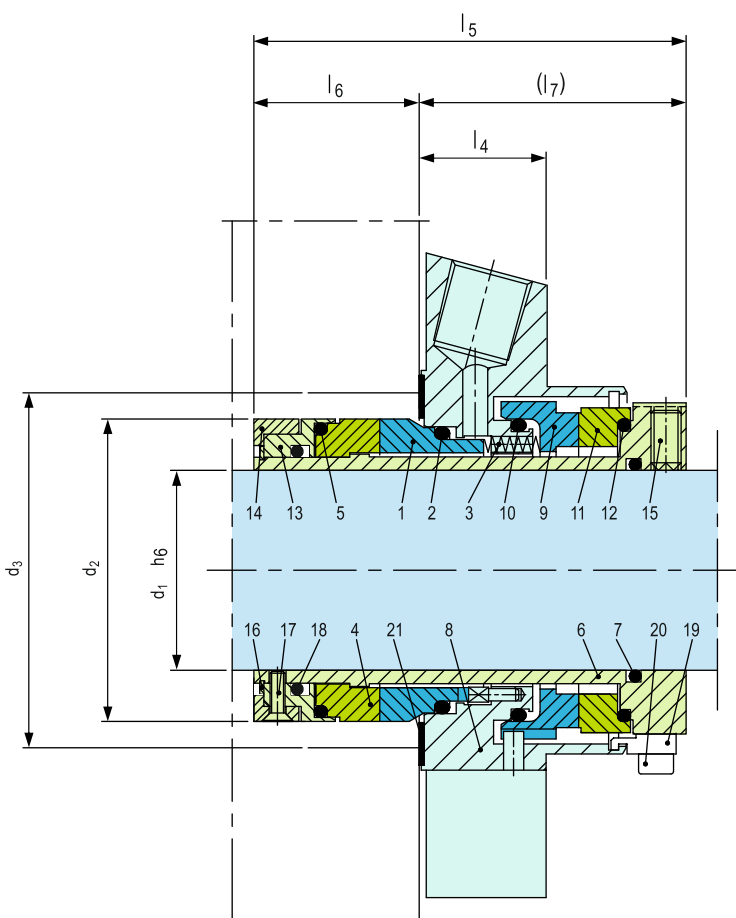

**Note:** The item numbers as depicted above are based on our technical experience and knowledge and are placed in the chronological order of their assembly procedure.

Item	Description
1,9	Seal face
2,5,7,10,12,18	O-ring
3	Spring
4,11	Seat
6	Shaft sleeve
8	Cover
13	Adapter

Item	Description
14	Ring
15	Set screw
16	Retaining ring
17	Counter-sunk socket screw
19	Assembly fixture
20	HSH Cap Screw
21	Gasket

### Typical Industrial Applications

Chemical industry  
Refining technology  
Gases and liquids  
Media which require high purity  
Environmental harmful media  
Pumps

### Materials

Seal face: Silicon carbide (Q1/Q19)  
Seat: Silicon carbide (Q19/Q1)  
Secondary seals: FKM (V), EPDM (E), FFKM (K)  
Spring: Hastelloy® C-4 (M)  
Metal parts: CrNiMo steel (G), Hastelloy® C-4 (M)

### Performance Capabilities

Shaft diameter:  
 $d_1 = 30 \dots 100 \text{ mm (1.18" ... 3.94")}$   
Pressure:  
 $p_1 = 13 \text{ bar (189 PSI)}$ ,  
 $p_3 = 16 \text{ bar (232 PSI)}$   
with V-grooves (uni-directional)  
 $p_1 = 9 \text{ bar (131 PSI)}$ ,  
 $p_3 = 12 \text{ bar (174 PSI)}$   
with U-grooves (bi-directional)  
Differential pressure ( $p_3 - p_1$ ) = min. 3 bar (44 PSI)  
Operating temperature limits for:  
EPDM -20 °C ... +140 °C (-4 °F ... +284 °F)  
FFKM -5 °C ... +300 °C (+23 °F ... +572 °F)  
FKM -20 °C ... +170 °C (-4 °F ... +338 °F)  
Speed = 4 ... 15 m/s (13 ... 49 ft/s)  
Axial movement:  $\pm 1.0 \text{ mm}$



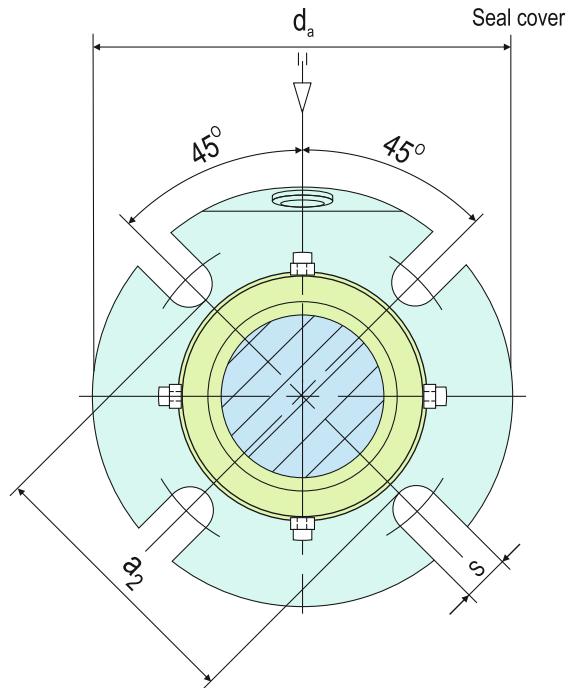

Dimensional Data

Dimensions in millimeter

$d_1$	$d_2$	$d_3$ min.	$d_3$ max.	$l_4$	$l_5$	$l_6$	$l_7$	$a_2$	$d_a$	$s$
30	52.0	54	57	25.4	86	33	53	67	105	14
33	55.0	57	60	25.4	86	33	53	70	108	14
35	57.5	59	62	25.4	86	33	53	72	110	14
38	61.0	63	70	25.4	86	33	53	75	123	14
40	61.0	63	70	25.4	86	33	53	77	123	16
43	64.0	66	70	25.4	86	33	53	80	133	16
45	67.0	68	75	25.4	86	33	53	82	138	16
48	70.0	71	77	25.4	86	33	53	85	138	16
50	71.0	73	78	25.4	86	33	53	87	148	16
53	75.3	77	82	28.5	89	33	56	97	148	18
60	83.5	85	90	28.5	89	33	56	104	155	18
65	93.0	95	102	25.4	100	41.6	58.4	116	163	18
70	101.0	102	110	25.4	100	41.6	58.4	124	178	18
75	107.0	108	119	28	107	41.6	65.4	129	193	18
80	111.0	111	124	28	107	41.6	65.4	129	198	18
90	121.0	121	131	28	107	41.6	65.4	140	205	22
100	130.0	132	144	28	107	41.6	65.4	154	218	22

**Note: Additional technical & dimensional information will be provided on request.**

The specifications, drawings, images etc included in this catalogue are intended to be generic and must be interpreted as equivalent or functionally equivalent, more specifically the performance capabilities mentioned in this catalogue is based on optimum values, however the performance of the product is dependent on size, material of construction, media, pressure, temperature, sliding velocity etc and it shall vary from size to size or application to application. Customers are requested to consult with Sealmatic before employing the product from this catalogue for any application.



### Product Description

1. Dual seal configuration
2. Balanced design
3. Independent of direction of rotation
4. Cartridge construction
5. Gas-lubricated design
6. Designed for top entry vessels

### Technical Features

1. Seal faces are designed to be non-contacting during operation
2. Designed for environmental protection with high efficiency
3. Due to non-contacting design there is no friction on the seal faces and there is no heat generated at the seal or in the medium
4. Trouble free operations as complex components are not required to dissipate frictional heat
5. To accommodate large axial movement torque transmission is through clamping ring
6. Rotating seat is designed and arranged in the center

### Typical Industrial Applications

Agitators  
 Chemical industry  
 Environmental harmful media with double seals  
 Food and beverage industry  
 Gases and liquids  
 Media which require high purity  
 Pharmaceutical industry

### Performance Capabilities

Shaft diameter:  $d_3 = 40 \dots 220 \text{ mm}$  (1.6" ... 8.7")  
 Pressure  $p_1 = \text{vacuum} \dots 6 \text{ bar}$  (87 PSI),  
 $\Delta p = \text{min. } 3 \text{ bar}$  (44 PSI),  $p_3 = 9 \text{ bar}$  (131 PSI)  
 Temperature:  $t_1 = -20^\circ\text{C} \dots +150^\circ\text{C}$  (-4°F ... +302°F),  
 with cooling flange  $250^\circ\text{C}$  (482 °F)  
 Speed =  $0 \dots 10 \text{ m/s}$  (0 ... 33 ft/s)

### Standards

DIN 28136 T2 (for steel vessels)  
 DIN 28141 (flange connection for steel vessels)  
 DIN 28154 (shaft end for steel vessel)  
 DIN 28136 T3 (for glass-lined vessels)  
 DIN 28137 T2 (flange connection for glass-lined vessels)

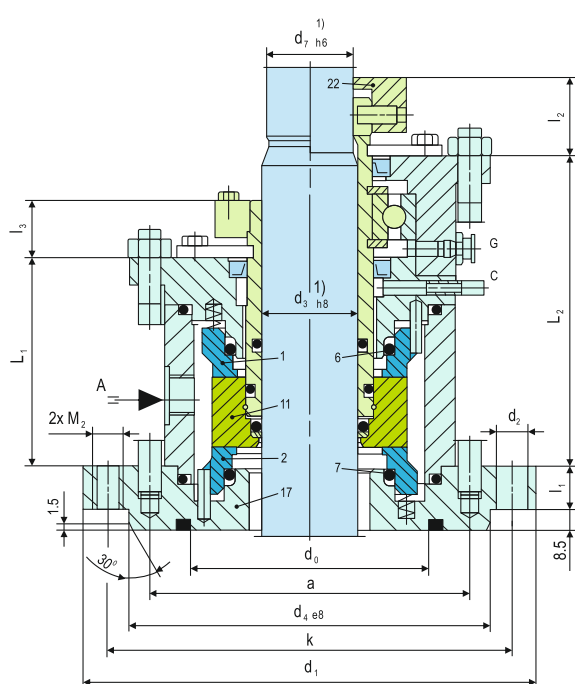

Item	Description
1	Seal face (Diamond Coated), atmosphere side
2	Seal face (Q1), product side
6,7	O-ring
11	Seat (Q1)
17	Flange
22	Clamping ring

### Design Variations

#### GSAZ184K(L)-D

Double seal (with integrated bearing) for steel vessels to DIN 28136, connection flange to DIN 28141 and shaft ends to DIN 28154.

Flange connection acc. to DIN 28137 T2 for nominal diameters 40 ... 100.

### Notes

Options:  
 Cooling or heating flange  
 Flush  
 Polymerization barrier

### Installation, Details, Options

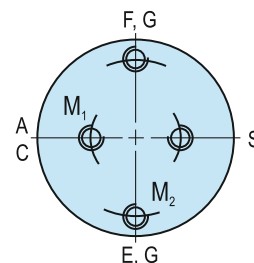

### Supply connections

Designation and positions of supply connections, pull-off and jacket threads acc. to DIN 28138 T3.

A	Barrier gas IN
C	Leakage
E	Cooling IN
F	Cooling OUT
S	Flush
G	Grease

### Torque Transmissions

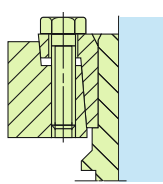

Shrink disk

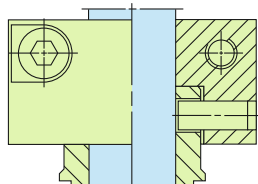

Clamping ring with pin

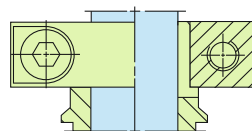

Clamping ring

Note: The item numbers as depicted above are based on our technical experience and knowledge and are placed in the chronological order of their assembly procedure.

## Installation, Details, Options

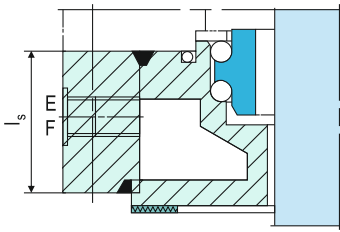

### Option

Cooling flange, can be used alternatively as a heating flange ( $t_{max.} = 350^{\circ}\text{C}$  (662  $^{\circ}\text{F}$ )).

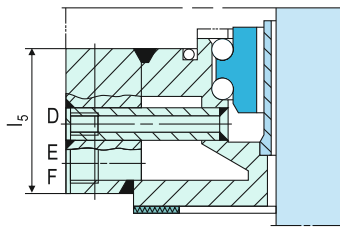

### Option

Leakage drain, can be used alternatively as a flush or as a heating flange.

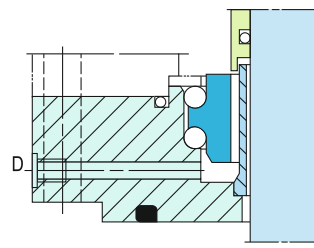

### Option

Leakage drain, can be used alternatively as a flush

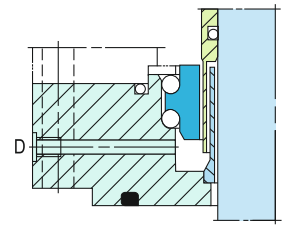

### Option

Polymerization barrier, can be used alternatively as a leakage drain or a flush.

## Design Variations

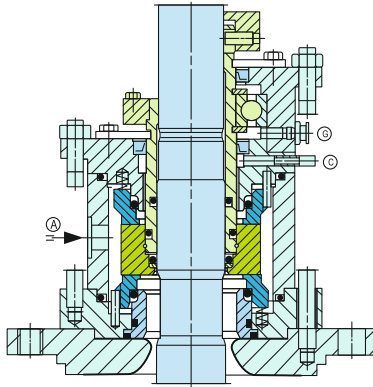

### GSAZ164K(L)-D

Double seal (with integrated bearing) for glass-lined vessels to DIN 28136, connection flange to DIN 28137 and shaft ends to DIN 28159.

Flange connection acc. to DIN 28137 T2 for nominal diameters 125 ... 161.

## Dimensional Data

### GSAZ184 - Dimensions in millimeter

$d_3^{1)}$	$d_7^{1)}$	$d_1$	$n \times d_2$	$d_4$	$d_0$	$k$	$L_1$	$L_2$	$L_w^{1)}$	$I_1$	$I_2$	$I_3$	$a$	$M_1$	$M_2$	A, B
40	38	175	4x18	110	90	145	81	137	143	15	35	28	122	M12	M16	G3/8
50	48	240	8x18	176	135	210	82.5	130.5	148	17	42	28	155	M12	M16	G3/8
60	58	240	8x18	176	135	210	78.5	128	158	18	39	28	176	M12	M16	G3/8
80	78	275	8x22	204	155	240	94.5	146	168	20	50	34	203	M16	M20	G1/2
100	98	305	8x22	234	190	270	95	156.5	178	20	56.5	34	228	M16	M20	G1/2
125	120	330	8x22	260	215	295	95	163.5	203	20	60	39	268	M20	M20	G1/2
140	135	395	12x22	313	250	350	97	168.5	208	20	82	41	285	M20	M20	G1/2
160	150	395	12x22	313	265	350	97	176.5	213	25	81	41	302	M20	M20	G1/2
180	170	445	12x22	364	310	400	-	-	233	25	-	-	332	M24	M20	G1/2
200	190	445	12x22	364	310	400	-	-	243	25	-	-	352	M24	M20	G1/2
220	210	505	16x22	422	340	460	-	-	263	25	-	-	-	M24	M20	G1/2

1) Shaft diameters  $d_3$  and  $d_7$  to DIN 28154

### GSAZ164 - Dimensions in millimeter

$d_3^{1)}$	$d_7^{1)}$	Nominal size	Flange size <sup>2)</sup>	$d_1$	$n \times d_2$	$d_4$	$n \times d_5$	$d_6$	$d_7$	$k_1$	$k_2$	$I_1$	$I_2$	$I_1$	$I_2$	$I_3$	$I_4$	$I_5$	$M_1$	$M_2$	A
40	38	40	E125	175	4x18	110	-	-	102	145	-	142	184	25	35	28	50	50	M12	M16	G3/8
50	48	50	E200	240	8x18	176	-	-	138	210	-	147	195	25	40	28	50	50	M12	M16	G3/8
60	58	60	E250	275	8x22	204	-	-	188	240	-	158	203	25	42	28	50	60	M12	M20	G3/8
80	78	80	E300	305	8x22	234	-	-	212	270	-	170	240	30	45	34	60	60	M16	M20	G1/2
100	98	100	E400	395	12x22	313	-	-	268	350	-	177	240	30	52	34	60	60	M16	M20	G1/2
100	98	100	E500	395	12x22	313	-	-	268	350	-	177	240	30	52	34	60	60	M16	M20	G1/2
125	120	125	E700	505	4x22	422	12x22	320	306	460	350	208	266	30	75	40	60	80	M20	M20	G1/2
140	135	140	E700	505	4x22	422	12x22	320	306	460	350	223	282	30	79	40	60	80	M20	M20	G1/2
160	150	160	E700	505	4x22	422	12x22	320	306	460	350	228	282	30	77	40	60	85	M20	M20	G1/2
160	150	160	E900	505	4x22	422	12x22	320	306	460	350	228	282	30	77	40	60	85	M20	M20	G1/2
160	150	161	E901	565	4x26	474	12x22	370	356	515	400	228	282	30	77	40	60	85	M20	M20	G1/2

1) Shaft diameters  $d_3$  and  $d_7$  to DIN 28159

2) Flange size to DIN 28137T2

Note: Additional technical & dimensional information will be provided on request

The specifications, drawings, images etc included in this catalogue are intended to be generic and must be interpreted as equivalent or functionally equivalent, more specifically the performance capabilities mentioned in this catalogue is based on optimum values, however the performance of the product is dependent on size, material of construction, media, pressure, temperature, sliding velocity etc and it shall vary from size to size or application to application. Customers are requested to consult with Sealmatic before employing the product from this catalogue for any application.



### Product Description

1. Dual seal configuration
2. Unbalanced design
3. Independent of direction of rotation
4. Cartridge construction
5. Designed for top, side and bottom entry vessels
6. Design of the product side seat is rotary

### Technical Features

1. Design with CIP-/SIP (Cleaning in Place, Sterilization in Place)
2. Smooth construction of surfaces with no empty crevices
3. Sterile application design available
4. Rugged design to ensure long term reliability and operating life
5. Seals are assembled in cartridge construction for easy fitment
6. Over all connecting dimensions are tailor made to customer's specifications

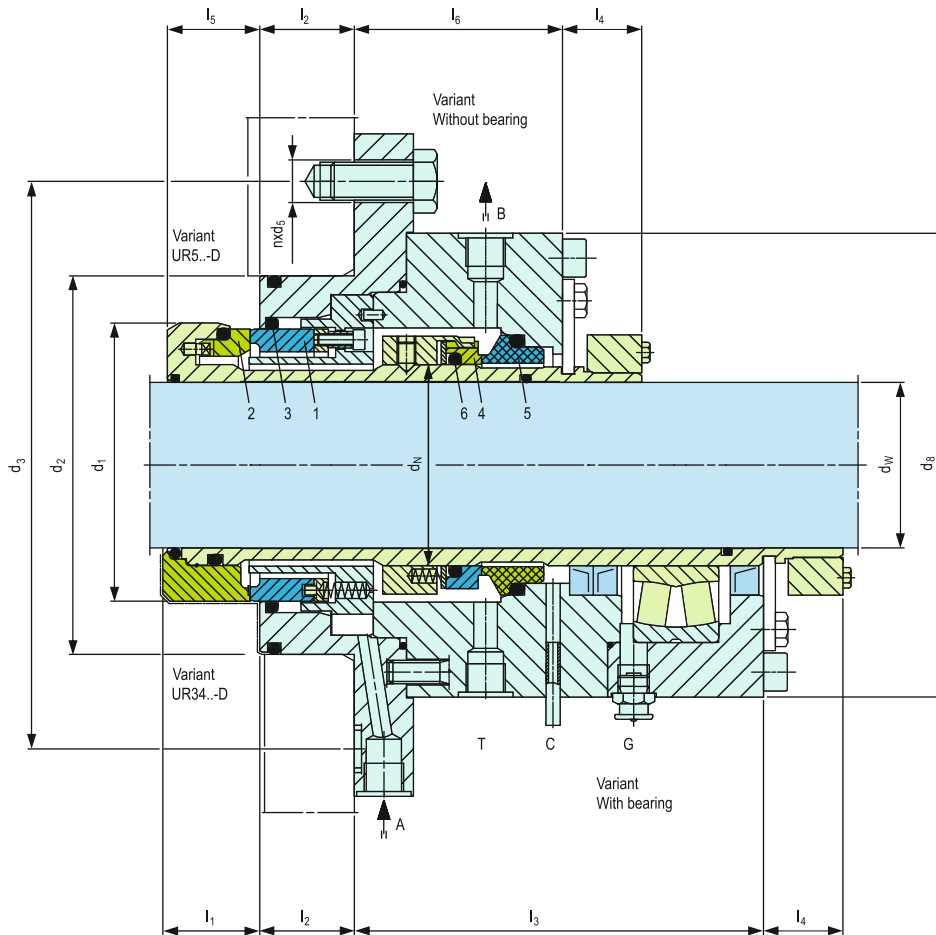

**Note:** The item numbers as depicted above are based on our technical experience and knowledge and are placed in the chronological order of their assembly procedure.

Item	Description
1	Seal face, product side
2	Seat, product side
3	O-ring, dynamic
4	Seal face, atmosphere side
5	Seat, atmosphere side
6	O-ring, dynamic

### Installation, Details, Options

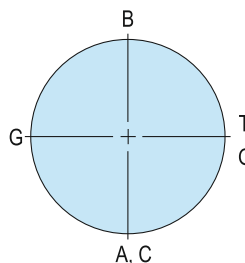

### Supply Connections

A	Barrier fluid IN
B	Barrier fluid OUT
C	Drainage
G	Grease
T	Temperature measuring

### Typical Industrial Applications

Chemical industry      Kneaders  
 Food and beverage industry      Mills  
 Pharmaceutical industry      Mixers  
 Dryers      Pressure filters  
    Reactors

### Materials

Product side :  
 Seal face, seat: Silicon carbide (Q1),  
 Tungsten carbide (U)  
 Metal parts: Cr steel (E), CrNiMo steel (G),  
 Hastelloy® (M)  
 Atmosphere side:  
 Seal face, seat: Silicon carbide (Q1), Carbon  
 graphite resin impregnated (B)  
 Metal parts: Cr steel (E), CrNiMo steel (G)  
 Product and atmosphere side:  
 Springs: CrNiMo steel (G), Hastelloy® (M)  
 Secondary seals: EPDM (E), FKM (V),  
 FFKM (K), FKM, FEP wrapped (M5)  
 Other materials on request.

### Standards

FDA  
**Notes**  
 Options:  
 Cooling or heating flange  
 Temperature probe  
 Axial expansion joint (shaft lifting)  
 Wiper ring (shaft lifting)

### Performance Capabilities

Sizes:  $d_N/d_w =$  Upto 200 (500) mm  
 (Upto 7.875" (20.00"))  
 Axial offset shaft/housing:  
 $d_N/d_w 30... 60\text{mm}$  (1.18"...2.36"): max.  $\pm 1.5\text{mm}$   
 (0.059")  
 $d_N/d_w > 60\text{mm}$  (2.36"): max.  $\pm 2.0\text{mm}$  (0.079")  
 Radial offset shaft/housing: max.  $\pm 0.3\text{mm}$   
 (0.012")  
 Pressure:  
 $p_1$  (media) = vacuum...14 (23) bar (203  
 (334 PSI))  
 $p_3$  (buffer fluid) = max. 16 (25) bar (232  
 (363 PSI))  
 $\Delta p_3 > p_1 =$  min. 2 bar (29 PSI), max. 10 bar  
 (145 PSI)  
 Temperature:  
 $t_1$  (media) = -20 °C ... +200 (300) °C  
 (-4 °F ... +392 (572) °F)  
 Speed = 20 m/s (66 ft/s)

### Torque Transmissions

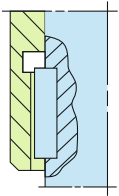

Drive key

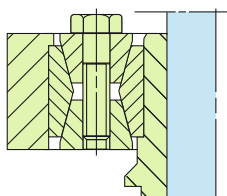

Clamping set

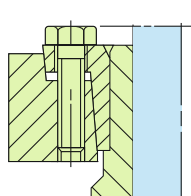

Shrink disc

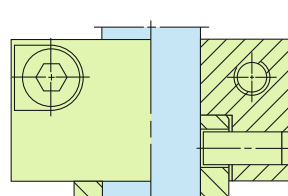

Clamping ring  
with pin

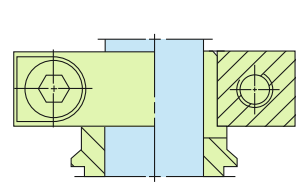

Clamping ring

### Dimensional Data

#### Dimensions in millimeter

$d_N$	$d_w$	$d_1$	$d_2$	$d_3$	$d_8$	$l_1$	$l_2$	$l_3$	$l_4$	$l_5$	$l_6$	$l_7$	A,B	$nxd_5$
30	20	52	117	140	118	35	30	114	30	22	75	41	G3/8	6X11
35	25	58	124	150	128	35	30	127	30	22	85	41	G3/8	6X11
40	30	62	134	165	138	35	30	129	30	24	87	41	G3/8	6X11
45	35	68	140	175	148	35	30	130	30	24	87	41	G3/8	6X11
50	40	75	145	175	148	35	30	133	34	26	90	41	G3/8	8X11
55	45	82.7	150	175	148	35	30	135	34	26	90	41	G3/8	8X11
60	50	85	160	185	158	41	30	150	34	30	105	41	G3/8	8X11
65	50	90	170	195	168	41	30	160	34	30	105	41	G3/8	8X11
70	55	95	175	205	178	41	30	160	34	30	105	41	G3/8	8X11
75	60	100	180	205	178	41	30	160	34	30	105	41	G3/8	8X11
80	65	110	190	220	188	41	40	190	44	30	105	41	G3/8	8X14
85	70	115	195	230	198	41	40	190	44	30	105	41	G3/8	8X14
90	75	120	200	230	198	41	40	190	44	30	105	41	G3/8	8X14
95	80	127	205	235	203	41	40	190	44	30	105	41	G3/8	8X14
100	80	130	210	240	208	41	40	190	44	30	105	45	G3/8	8X14
105	85	135	215	250	218	41	40	190	44	30	105	45	G1/2	8X14
110	90	140	230	260	228	41	40	190	44	31	110	45	G1/2	8X14
115	95	145	235	270	238	41	40	190	44	31	110	45	G1/2	8X14
120	100	150	240	270	238	42	40	200	44	31	120	46	G1/2	8X14
130	110	160	255	290	258	42	40	200	50	31	120	46	G1/2	8X14
140	120	172	265	305	268	43	50	220	50	41	130	46	G1/2	8X18
150	130	185	275	315	278	43	50	220	50	41	130	46	G1/2	8X18
160	140	195	290	335	298	43	50	220	50	41	130	46	G1/2	8X18
170	150	205	300	335	298	47	50	220	50	45	130	46	G1/2	8X18
180	160	220	330	355	323	47	50	250	50	45	140	46	G1/2	8X18
190	170	230	345	375	358	47	50	250	55	45	140	46	G1/2	8X18
200	180	240	365	395	358	47	50	250	55	45	140	51	G1/2	8X18
210	190	260	385	415	378	50	50	250	55	45	140	51	G1/2	12X18
220	190	270	395	425	388	50	50	250	55	45	140	51	G1/2	12X18
230	200	280	395	425	388	50	50	300	55	45	160	51	G1/2	12X18

$d_N > 230$  on request

inch size available from size 1.125 to 9.000

Note: Additional technical & dimensional information will be provided on request.

The specifications, drawings, images etc included in this catalogue are intended to be generic and must be interpreted as equivalent or functionally equivalent, more specifically the performance capabilities mentioned in this catalogue is based on optimum values, however the performance of the product is dependent on size, material of construction, media, pressure, temperature, sliding velocity etc and it shall vary from size to size or application to application. Customers are requested to consult with Sealmatic before employing the product from this catalogue for any application.



### Product Description

1. Single and Dual seal configuration
2. Balanced design
3. Independent of direction of rotation
4. Cartridge construction
5. Designed for dry running applications
6. Designed for top entry vessels, side entry can be provided upon request
7. Rotary unit with multiple springs

### Technical Features

1. Over all connecting dimensions are tailor made to customer's specifications
2. Can accommodate reverse pressure
3. The seal design is unique as it closes due to the hydraulic product pressure as well as overlaying barrier pressure
4. Rugged design to ensure long term reliability and operating life
5. Seals are assembled in cartridge construction for easy fitment and are also available in component design as per customer specification

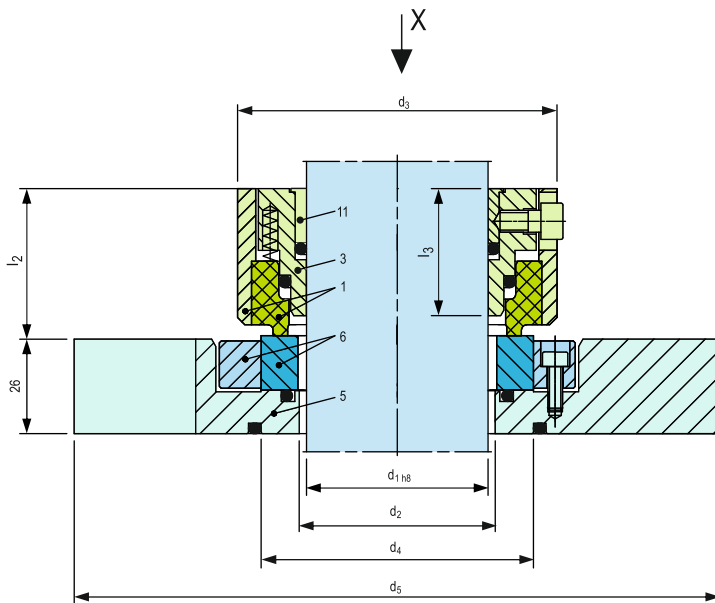

**Note:** The item numbers as depicted above are based on our technical experience and knowledge and are placed in the chronological order of their assembly procedure.

### Typical Industrial Applications

Chemical industry  
 Food and beverage industry  
 Non-toxic media with single seal  
 Pharmaceutical industry  
 Toxic media with double seal  
 Agitators  
 Reactors

### Standards

FDA  
 ATEX  
 DIN 28136 T2 (for steel vessels)  
 DIN 28141 (flange connection for steel vessels)  
 DIN 28154 (shaft end for steel vessels)  
 DIN 28136 T3 (for glass-lined vessels)  
 DIN 28137 T2 (flange connection for glass-lined vessels)  
 DIN 28159 (shaft end for glass-lined vessels)

### Materials

Seal face: Carbon graphite, FDA conform  
 Seat: Silicon carbide (Q1)  
 Secondary seals and metal parts according to application and customer's specifications

### Notes

Seat alternatives available on request.  
 Options:  
 Cooling or heating flange  
 Flush  
 Polymerization barrier

### Installation, Details, Options

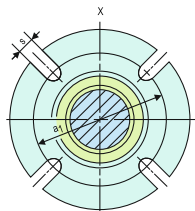

Seal flange

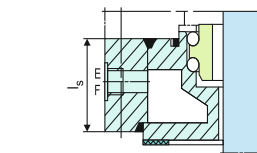

#### Option

Cooling flange, can be used alternatively as a heating flange ( $t_{max} = 350^{\circ}\text{C}$  (662  $^{\circ}\text{F}$ )).

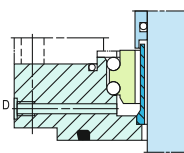

#### Option

Leakage drain, can be used alternatively as a flush.

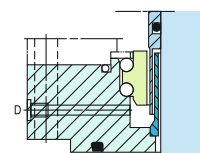

#### Option

Polymerization barrier, can be used alternatively as a leakage drain or a flush.

Item	Description
1	Seal face with seal face housing
3	Drive collar
5	Flange
6	Seat with seat housing
11	Clamping

### Performance Capabilities

Sizes:  $d_1 =$  Upto 160 mm (Upto 6.500")  
 Pressure:  $p_1 =$  vacuum ... 6 bar (87 PSI)  
 Temperature:  $t_1 = -20^{\circ}\text{C}$  ...  $+150$  (250\*)  $^{\circ}\text{C}$  (-4  $^{\circ}\text{F}$  ... 302 (482\*)  $^{\circ}\text{F}$   
 Speed = 0 ... 2 m/s (0 ... 6 ft/s)  
 Permissible axial movement:  $\pm 1.5$  mm  
 Radial movement:  $\pm 1.5$  mm

## Design Variations

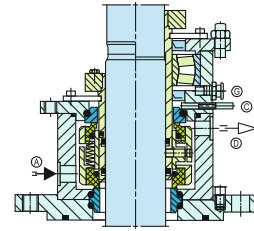
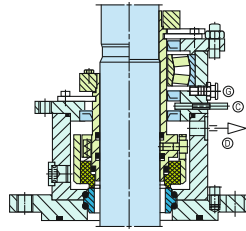
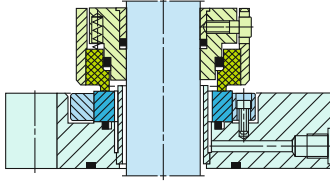

### MXS-110

The MXS-110 is equipped in addition with a sleeve for trapping any abrasive particles from the seal face. Contamination of the medium in the container is thus ruled out. The sleeve can be cleaned through a flushing bore.

Please note: diameters ( $d_2$  to  $d_5$ ) increase to the next possible design size.

### Single Seal Variants

#### MXS184

Single seal

#### MXS184L

Single seal with integrated floating bearing.

#### MXS154

All types of the MXS184 range available for unstepped shafts (all diameters). Seal identification: MXS154 ... Customized design or e.g. different drives (torque transmissions) are available.

#### MXS164 / 194

For glass-lined vessels. Dimensions as U164

### Double Seal Variants

#### MXS184-D

Double seal

#### MXS184L-D

Double seal with integrated floating bearing  
These seals are designed to be self-closing on the product side, i.e. they will remain closed even with pressure variations or a pressure reversal. Operation is optionally the same as for the single version. In view of the mechanical seal on the atmosphere side it can be used as a Barrier pressurized double seal. The barrier pressure should be 0.5 ... 1.0 bar (7.25 ... 15 PSI) above pressure to be sealed.

## Dimensional Data

### Dimensions in millimeter

$d_1$ (mm)	$d_1$ (inch)	$d_2$	$d_3$	$d_4$	$d_5$	$l_2$	$l_3$	$a_1$ (min)	$a_1$ (max)	s
25	1.000	34	68	-	148	41.5	40.5	100	132	11
28	1.125	34	68	55	148	41.5	40.5	100	132	11
30	-	34	68	55	148	41.5	40.5	100	132	11
32	1.250	39	73	60	153	41.5	40.5	105	137	11
35	1.375	39	73	60	153	41.5	40.5	105	137	11
38	1.500	44	78	65	158	41.5	40.5	110	142	11
40	-	44	78	65	158	41.5	40.5	110	142	11
45	1.625	49	83	68	163	41.5	40.5	115	152	11
-	1.750	49	83	68	163	41.5	40.5	115	152	11
48	1.875	54	88	73	178	41.5	40.5	125	160	14
50	-	54	88	75	178	41.5	40.5	125	160	14
55	2.000	59	93	78	183	41.5	40.5	130	165	14
-	2.125	59	93	78	183	41.5	40.5	130	165	14
60	2.250	64	98	85	183	41.5	40.5	135	170	14
65	2.375	69	103	90	193	44.5	40.5	140	175	14
-	2.500	69	103	90	193	44.5	40.5	140	175	14
70	2.625	74	108	95	198	44.5	43.5	145	180	14
-	2.750	74	108	95	198	44.5	43.5	145	180	14
75	2.875	79	113	100	203	44.5	43.5	150	185	14
80	3.000	84	118	105	208	44.5	43.5	155	190	14
85	3.250	89	123	110	213	44.5	43.5	160	195	14
90	3.500	94	128	115	218	44.5	43.5	165	200	14
95	3.750	99	133	120	223	44.5	43.5	170	205	14
100	-	104	138	125	228	44.5	43.5	175	210	14
105	4.000	109	143	130	233	44.5	43.5	180	215	14
110	4.250	114	148	135	238	44.5	43.5	185	220	14
115	4.500	119	153	140	267	44.5	43.5	196	243	18
125	4.750	129	163	150	277	44.5	43.5	206	253	18
140	5.000	144	178	165	297	44.5	43.5	221	273	18
-	5.250	144	178	165	297	44.5	43.5	221	273	18
-	5.500	144	178	165	297	44.5	43.5	221	273	18
150	5.750	154	188	175	307	44.5	43.5	231	283	18
160	6.000	164	198	185	317	44.5	43.5	241	293	18
-	6.250	164	198	185	317	44.5	43.5	241	293	18

### MXS164 - Dimensions in millimeter

$d_3^{1)}$	$d_7^{1)}$	$d_1$	$n \times d_2$	$d_4$	$d_0$	k	$L_1$	$L_2$	$L_w^{2)}$	$l_1$	$l_2$	A	$M_1$	$M_1$	A, B
40	38	175	4x18	110	90	145	87	136	143	15	28	122	M12	M16	G3/8
50	48	240	8x18	176	135	210	89	149	148	17	28	157	M12	M16	G3/8
60	58	240	8x18	176	135	210	93.5	156	158	17	28	168	M12	M16	G3/8
80	78	275	8x22	204	155	240	104.5	189	168	20	34	203	M16	M20	G1/2
100	98	305	8x22	234	190	270	109	190	178	20	34	228	M16	M20	G1/2
125	120	330	8x22	260	215	295	110	205	203	20	40	268	M20	M20	G1/2
140	135	395	12x22	313	250	350	124	222	208	20	40	285	M20	M20	G1/2
160	150	395	12x22	313	265	350	127.5	219.5	213	25	40	297	M20	M20	G1/2
180	170	445	12x22	364	310	400	132.5	230	233	25	45	332	M24	M20	G1/2
200	190	445	12x22	364	310	400	137.5	237.5	243	25	45	352	M24	M20	G1/2
220	210	505	16x22	422	340	460	149.5	249.5	263	25	50	381	M24	M20	G1/2

1) Shaft diameters  $d_3$  and  $d_7$  to DIN 28154

2) Shaft step to DIN 28154

inch size available from size 1.500 to 6.500

Note: Additional technical & dimensional information will be provided on request.

The specifications, drawings, images etc included in this catalogue are intended to be generic and must be interpreted as equivalent or functionally equivalent, more specifically the performance capabilities mentioned in this catalogue is based on optimum values, however the performance of the product is dependent on size, material of construction, media, pressure, temperature, sliding velocity etc and it shall vary from size to size or application to application. Customers are requested to consult with Sealmatic before employing the product from this catalogue for any application.

# U164 Single & Dual Seals

# Glass Lined Agitator Seals - Liquid Lubricated



### Product Description

1. Single and Dual seal configuration
2. Unbalanced design
3. Independent of direction of rotation
4. Cartridge construction
5. Designed for top entry vessels
6. Rotary unit with multiple springs
7. Construction with integrated bearing also available
8. For glass-lined vessels, design according to DIN 28138 T2

### Technical Features

1. Available with or without floating bearing
2. Double seals can be applied at higher pressure and rotating speed
3. Suitable for standardizations
4. Rugged design to ensure long term reliability and operating life
5. Seals are assembled in cartridge construction for easy fitment
6. Over all connecting dimensions are tailor made to customer's specifications
7. The seal design is unique as it closes due to the hydraulic product pressure as well as overlaying barrier pressure

### Typical Industrial Applications

Chemical industry  
 Non-toxic media with single seal  
 Pharmaceutical industry  
 Toxic media with double seal  
 Agitators  
 Reactors

### Materials

According to application and customer's specification.

### Performance Capabilities

Sizes:  $d_3 =$  Upto 160 mm (Upto 6.500")  
 Pressure:  $p_1 =$  vacuum ... 16 bar (232 PSI),  
 $p_3 =$  max. 18 bar (261 PSI)  
 Temperature:  $t_1 = -40$  °C... +200 (250) °C  
 (-40 °F ... +392 (482) °F)  
 Speed = 0 ... 5 m/s (0 ... 16 ft/s)

### Installation, Details, Options

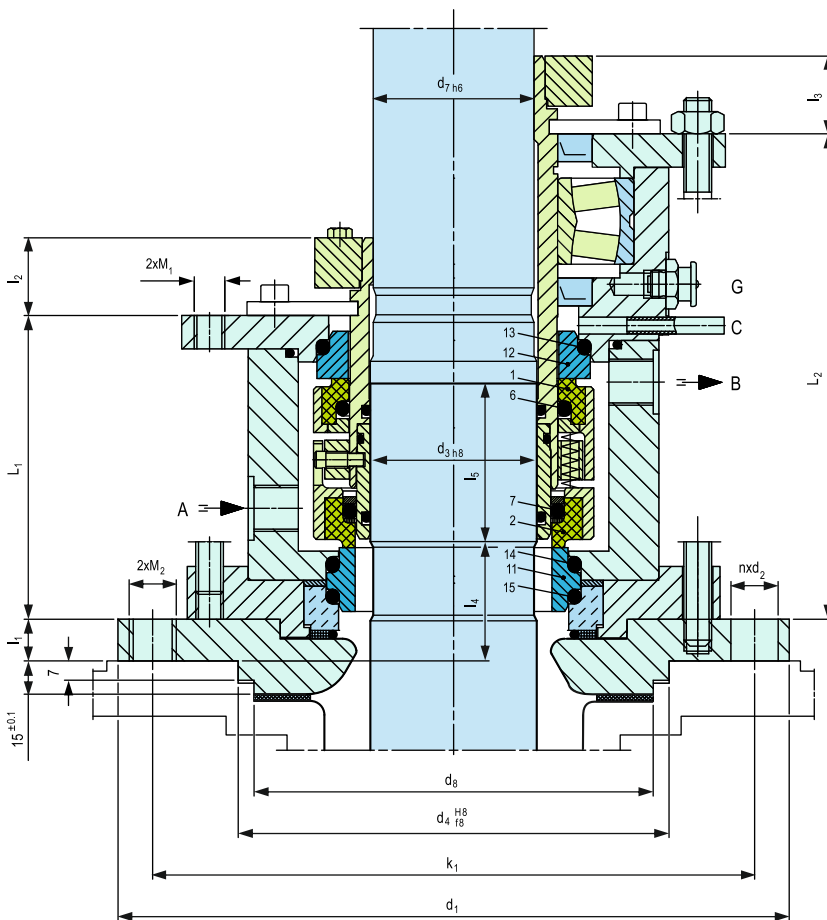

**Note:** The item numbers as depicted above are based on our technical experience and knowledge and are placed in the chronological order of their assembly procedure.

Item	Description
1	Seal face, atmosphere side
2	Seal face, product side
6,7,13	O-ring
14,15	
11	Seat, product side
12	Seat, atmosphere side

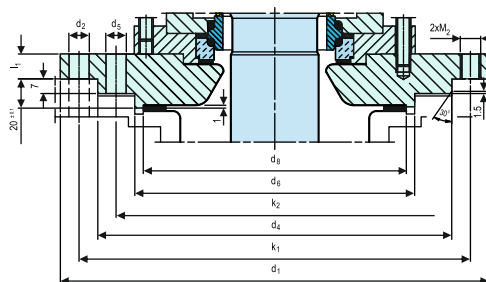

Flange connections acc. to DIN 28137 T2 for nominal diameters 125 ... 161.

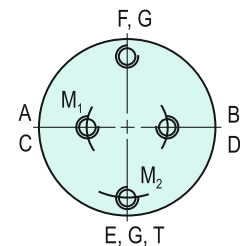

Supply connections  
 Designation and positions of screwed connections, pull-off and jacket threads acc. to DIN 28138 T3.

A	Barrier fluid resp. quench IN
B	Barrier fluid resp. quench OUT
C	Drainage
D	Leakage drain G1/8"
E	Cooling IN G3/8"
F	Cooling OUT G3/8"
G	Grease
H	Temperature metering



Standards
<b>FDA</b> DIN 28136 T3 (for glass-lined vessels) DIN 28137 T2 (flange connection for glasslined vessels) DIN 28159 (shaft end for glass-lined vessels)

Notes
<b>Options:</b> Cooling or heating flange Leakage drain, flush or heating flange Leakage drain or flush Polymerization barrier, leakage drain or flush

### Torque Transmissions

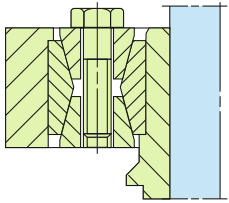

Clamping set

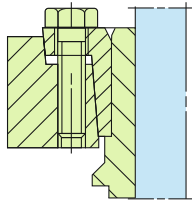

Shrink disk

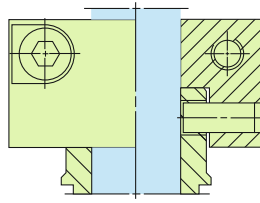

Clamping ring with pin

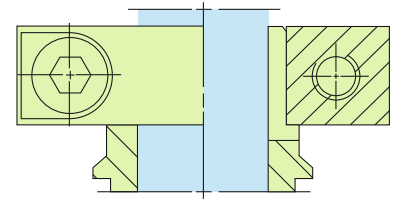

Clamping ring

### Installation, Details, Options

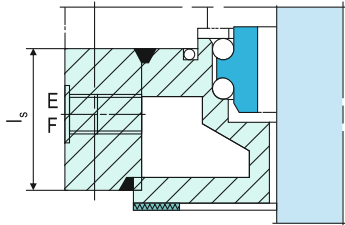

**Option**  
Cooling flange, can be used alternatively as a heating flange ( $t_{max.} = 350^{\circ}\text{C}$  (662 °F)).

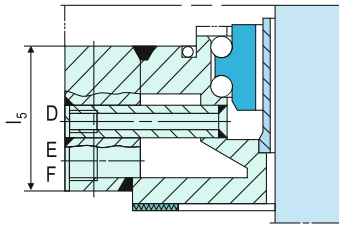

**Option**  
Leakage drain, can be used alternatively as a flush or as a heating flange.

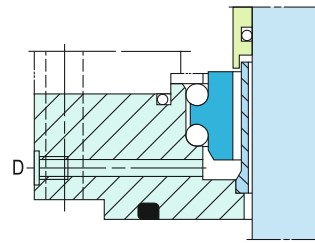

**Option**  
Leakage drain, can be used alternatively as a flush

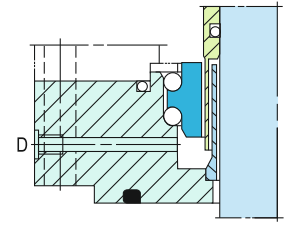

**Option**  
Polymerization barrier, can be used alternatively as a leakage drain or a flush.

### Design Variations

#### Double Seals Variants

- U164K-D**  
Double seal
- U164KL-D**  
Double seal with integrated floating bearing
- U156K(L)-D**  
Double seal with/without floating bearing for PN25

### Dimensional Data

#### Dimensions in millimeter

$d_3^{1)}$	$d_7^{1)}$	Nominal size	Flange size <sup>2)</sup>	$d_1$	$nxd_2$	$d_4$	$nxd_5$	$d_6$	$d_8$	$k_1$	$k_2$	$L_1$	$L_2$	$l_1$	$l_2$	$l_3$	$l_4$	$l_5$	$M_1$	$M_2$	A,B
40	38	40	E125	175	4X18	110	-	-	102	145	-	107	156	25	35	28	50	50	M12	M16	G3/8
50	48	50	E200	240	8X18	176	-	-	138	210	-	107	167	25	40	28	50	50	M12	M16	G3/8
60	58	60	E250	275	8X22	204	-	-	188	240	-	116	175	30	42	28	50	60	M12	M20	G3/8
80	78	80	E300	305	8X22	234	-	-	212	270	-	125	206	30	45	34	60	60	M16	M20	G1/2
100	98	100	E400	395	12X22	313	-	-	268	350	-	125	206	30	52	34	60	60	M16	M20	G1/2
100	98	100	E500	395	12X22	313	-	-	268	350	-	125	206	30	52	34	60	60	M16	M20	G1/2
125	120	125	E700	505	4X22	422	12X22	320	306	460	350	133	226	30	75	40	60	80	M20	M20	G1/2
140	135	140	E700	505	4X22	422	12X22	320	306	460	350	144	242	30	79	40	60	80	M20	M20	G1/2
160	150	160	E700	505	4X22	422	12X22	320	306	460	350	151	242	30	77	40	60	85	M20	M20	G1/2
160	150	160	E900	505	4X22	422	12X22	320	306	460	350	151	242	30	77	40	60	85	M20	M20	G1/2
160	150	161	E901	565	4X26	474	12X22	370	356	515	400	151	242	30	77	40	60	85	M20	M20	G1/2

1) Shaft diameters  $d_3$  and  $d_7$  to DIN 28159

2) Flange size to DIN 28137T2

inch size available from size 1.575 to 6.500

Note: Additional technical & dimensional information will be provided on request.

The specifications, drawings, images etc included in this catalogue are intended to be generic and must be interpreted as equivalent or functionally equivalent, more specifically the performance capabilities mentioned in this catalogue is based on optimum values, however the performance of the product is dependent on size, material of construction, media, pressure, temperature, sliding velocity etc and it shall vary from size to size or application to application. Customers are requested to consult with Sealmatic before employing the product from this catalogue for any application.

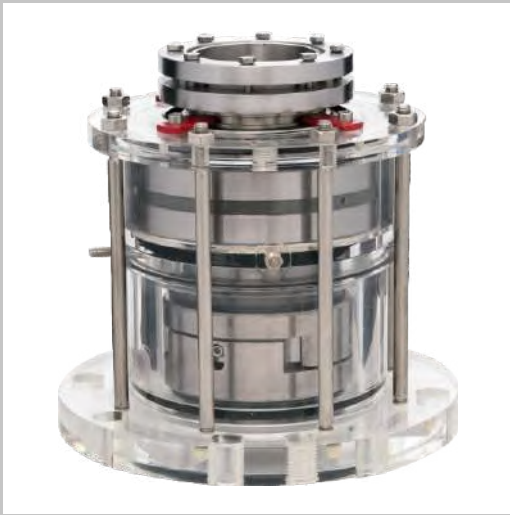

### Product Description

1. Single and Dual seal configuration
2. Unbalanced design
3. Independent of direction of rotation
4. Cartridge construction
5. Designed for top entry vessels
6. Rotary unit with multiple springs
7. Construction with integrated bearing also available

### Technical Features

1. Available with or without floating bearing
2. Double seals can be applied at higher pressure and rotating speed
3. Suitable for standardizations
4. Rugged design to ensure long term reliability and operating life
5. Seals are assembled in cartridge construction for easy fitment
6. Over all connecting dimensions are tailor made to customer's specification
7. The seal design is unique as it closes due to the hydraulic product pressure as well as overlaying barrier pressure

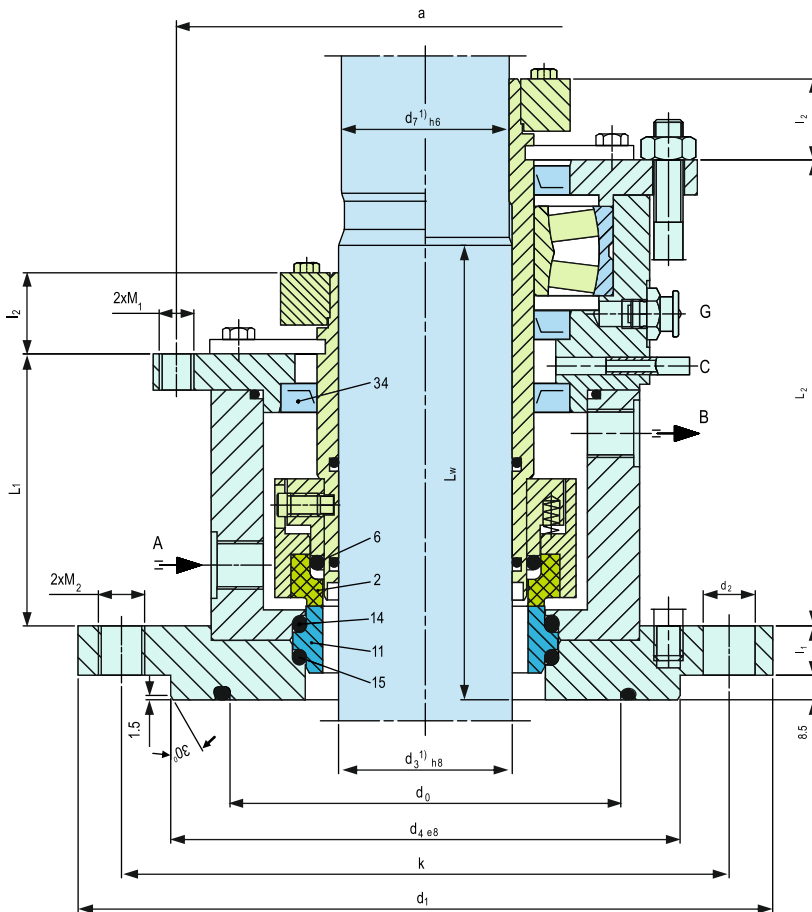

**Note:** The item numbers as depicted above are based on our technical experience and knowledge and are placed in the chronological order of their assembly procedure.

### Typical Industrial Applications

- Agitators
- Chemical industry
- Non-toxic media with single seal
- Pharmaceutical industry
- Reactors
- Toxic media with double seal

### Performance Capabilities

- DIN 28138 T2
- Sizes:  $d_3 = 40 \dots 220 \text{ mm}$  (1.575" ... 8.625")
- Single seals:
  - Pressure:  $p_1 = \text{vacuum} \dots 6 \text{ bar}$  (87 PSI),
  - $p_3 = \text{pressure less}$
  - Temperature:  $t_1^* = -40 \text{ }^\circ\text{C} \dots +150 \text{ (250) }^\circ\text{C}$
  - $(-40 \text{ }^\circ\text{F} \dots +302 \text{ (482) }^\circ\text{F})$
- Double seals:
  - Pressure:  $p_1 = \text{vacuum} \dots 16 \text{ bar}$  (232 PSI),
  - $p_3 = \text{max. } 18 \text{ bar}$  (261 PSI)
  - Temperature:  $t_1^* = -40 \text{ }^\circ\text{C} \dots +200 \text{ (350) }^\circ\text{C}$
  - $(-40 \text{ }^\circ\text{F} \dots +392 \text{ (662) }^\circ\text{F})$
  - Speed =  $0 \dots 5 \text{ m/s}$  ( $0 \dots 16 \text{ ft/s}$ )
  - \* Higher or lower temperatures on request.

### Standards

- FDA**
- DIN 28136 T2 (for steel vessels)
- DIN 28141 (flange connection for steel vessels)
- DIN 28154 (shaft end for steel vessels)

### Notes

- Options:
  - Cooling or heating flange
  - Leakage drain, flush or heating flange
  - Leakage drain or flush
  - Polymerization barrier, leakage drain or flush

### Torque Transmissions

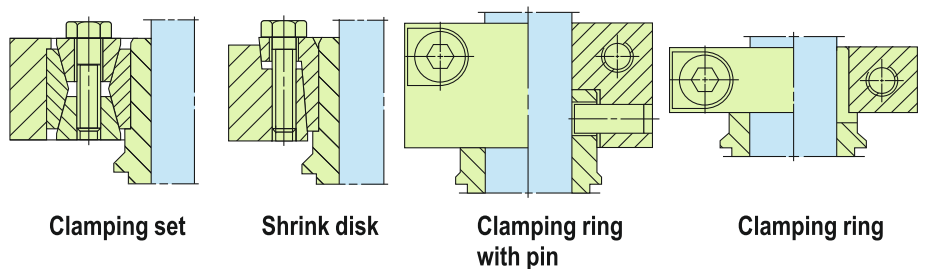

## Installation, Details, Options

### Supply connections

Designation and position acc. to DIN 28138 T3.

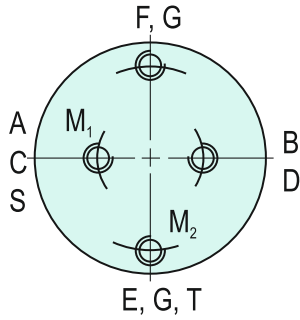

A	Barrier fluid resp. quench IN
B	Barrier fluid resp. quench OUT
C	Drainage
D	Leakage drain G1/8"
E	Cooling IN G3/8"
F	Cooling OUT G3/8"
G	Grease
S	Flush
T	Temperature metering

For reasons of standardization, the supply connections of single seals are matched to those of the double seals (in deviation from DIN 28138 T3).

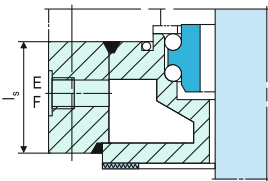

**Option**  
Cooling flange, can be used alternatively as a heating flange ( $t_{max} = 350^{\circ}\text{C}$  (662 $^{\circ}\text{F}$ )).

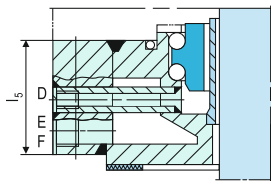

**Option**  
Leakage drain, can be used alternatively as a flush or as a heating flange.

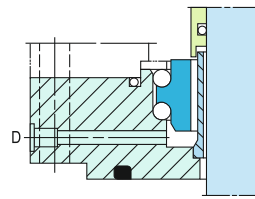

**Option**  
Leakage drain, can be used alternatively as a flush.

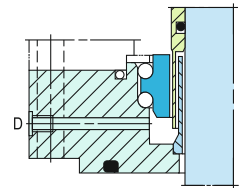

**Option**  
Polymerization barrier, can be used alternatively as a leakage drain or a flush.

## Design Variations

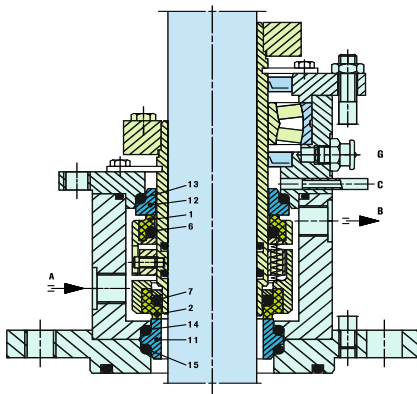

### Single Seals Variants

#### U184K

Single seal

#### U184KL

Single seal with integrated floating bearing.

Operation of single seals only with pressure less quench.

### Double Seals Variants

#### U184K-D

Double seal

#### U184KL-D

Double seal with integrated floating bearing.

These seals are designed to be self-closing on the product side, i.e. they will remain closed even with pressure variations or a pressure reversal. Operation is optionally the same as for the single version

( $p_{max} = 6 \text{ bar}$  (87 PSI) or

$\Delta p_{max} = 6 \text{ bar}$  at  $p_1 > p_3$ ).

In view of the mechanical seal on the atmosphere side it can be used as a buffer pressurized double seal

$p_1 = 16 \text{ bar}$  (232 PSI).

### U154

All types of the U184 range available for unstepped shafts (all diameters). Seal identification: U154... Customized design or e.g. different drives (torque transmissions) are available.

## Dimensional Data

### Dimensions in millimeter

$d_3^{1)}$	$d_7^{1)}$	$d_1$	$n \times d_2$	$d_4$	$d_0$	$k$	$L_1$	$L_2$	$L_w^{2)}$	$l_1$	$l_2$	$a$	$M_1$	$M_2$	A, B
40	38	175	4X18	110	90	145	87	136	143	15	28	122	M12	M16	G3/8
50	48	240	8X18	176	135	210	89	149	148	17	28	157	M12	M16	G3/8
60	58	240	8X18	176	135	210	93.5	156	158	17	28	168	M12	M16	G3/8
80	78	275	8X22	204	155	240	104.5	189	168	20	34	203	M16	M20	G1/2
100	98	305	8X22	234	190	270	109	190	178	20	34	228	M16	M20	G1/2
125	120	330	8X22	260	215	295	110	205	203	20	40	268	M20	M20	G1/2
140	135	395	12X22	313	250	350	124	222	208	20	40	285	M20	M20	G1/2
160	150	395	12X22	313	265	350	127.5	219.5	213	25	40	302	M20	M20	G1/2
180	170	445	12X22	364	310	400	132.5	230	233	25	45	332	M24	M20	G1/2
200	190	445	12X22	364	310	400	137.5	237.5	243	25	45	352	M24	M20	G1/2
220	210	505	16X22	422	340	460	149.5	249.5	263	25	50	381	M24	M20	G1/2

1) Shaft diameters  $d_3$  and  $d_7$  to DIN 28154

2) Shaft step to DIN 28154

inch size available from size 1.500 to 8.625

Note: Additional technical & dimensional information will be provided on request.

The specifications, drawings, images etc included in this catalogue are intended to be generic and must be interpreted as equivalent or functionally equivalent, more specifically the performance capabilities mentioned in this catalogue is based on optimum values, however the performance of the product is dependent on size, material of construction, media, pressure, temperature, sliding velocity etc and it shall vary from size to size or application to application. Customers are requested to consult with Sealmatic before employing the product from this catalogue for any application.



### Product Description

1. Dual seal configuration
2. Balanced design
3. Independent of direction of rotation
4. Cartridge construction
5. Designed for top entry vessels
6. Rotary unit with multiple springs
7. Integrated bearing construction available on request

### Technical Features

1. Over all connecting dimensions are tailor made to customer's specifications
2. Specially designed to handle high operating pressure
3. The seal design is unique as it closes due to the hydraulic product pressure as well overlaying barrier pressure
4. Rugged design to ensure long term reliability and operating life
5. Seals are assembled in cartridge construction for easy fitment

### Typical Industrial Applications

Chemical industry	Dryers
Pharmaceutical industry	Mixers
Suitable for all media	Filter
Agitators	Special rotating equipment

### Performance Capabilities

Shaft diameter:  $d_w = 20 \dots 400 \text{ mm}$  (0.79" ... 15.75")  
 Pressure:  $p_1 = \text{vacuum} \dots 250 \text{ bar}$  (... 3,625 PSI)\*,  $p_3 = p_1 + 10 \%$   
 Temperature:  $t = -40 \text{ }^\circ\text{C} \dots +200 \text{ (350) }^\circ\text{C}$   
 (-40 °F ... +392 (662) °F)  
 Sliding velocity:  $v_g = 0 \dots 5 \text{ m/s}$  (0 ... 16 ft/s)  
 For application beyond this range, please enquire.

### Materials

According to application and customer's specification

### Standards

FDA

### Notes

Options:  
 Cooling or heating flange  
 Leakage drain, flush or heating flange  
 Leakage drain or flush  
 Polymerization barrier, leakage drain or flush

### Product variants

Double seal variants  
 BSH(V)-D  
 Double seal  
 BSH(V)L-D  
 Double seal with integrated floating bearing (axial thrust bearing on request).

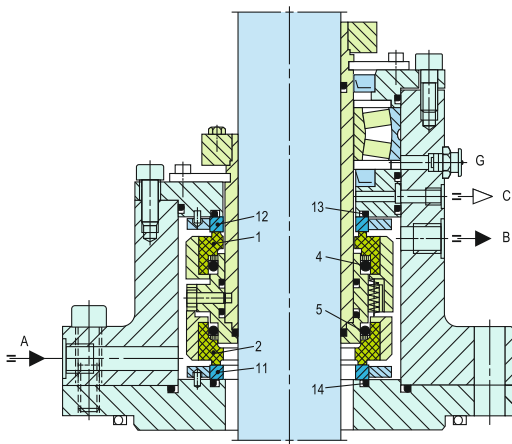

Item	Description
1	Seal face, atmosphere side
2	Seal face, product side
4, 5, 13, 14	O-ring
11	Seat, product side
12	Seat, atmosphere side

### Torque Transmissions

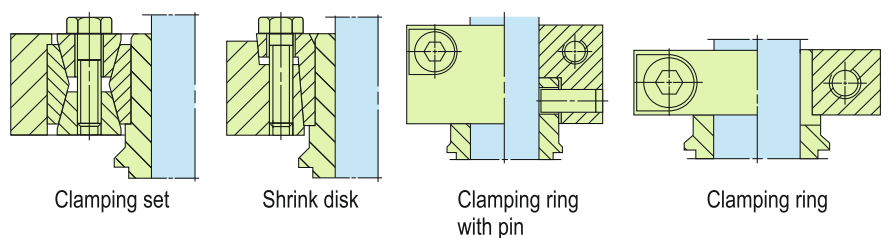

### Installation, Details, Options

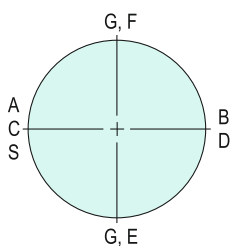

#### Supply connections

- A Barrier fluid IN
- B Barrier fluid OUT
- C Drainage
- D Leakage drain G1/8"
- E Cooling IN G3/8"
- F Cooling OUT G3/8"
- G Grease
- S Flush

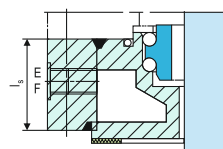

**Option**  
 Cooling flange, can be used alternatively as a heating flange ( $t_{max} = 350^\circ\text{C}$  (662 °F)).

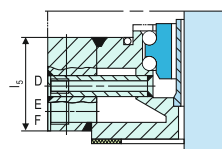

**Option**  
 Leakage drain, can be used alternatively as a flush or as a heating flange.

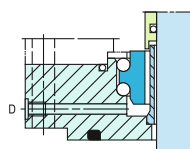

**Option**  
 Leakage drain, can be used alternatively as a flush.

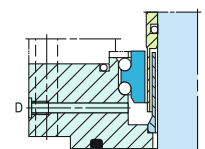

**Option**  
 Polymerization barrier, can be used alternatively as a leakage drain or a flush.

The specifications, drawings, images etc included in this catalogue are intended to be generic and must be interpreted as equivalent or functionally equivalent, more specifically the performance capabilities mentioned in this catalogue is based on optimum values, however the performance of the product is dependent on size, material of construction, media, pressure, temperature, sliding velocity etc and it shall vary from size to size or application to application. Customers are requested to consult with Sealmatic before employing the product from this catalogue for any application.



### Product Description

1. Dual seal configuration
2. Balanced design
3. Independent of direction of rotation
4. Cartridge construction
5. Designed for bottom entry vessels
6. Rotary unit with multiple springs
7. Construction with integrated bearing

### Technical Features

1. Over all connecting dimensions are tailor made to customer's specifications
2. Specially designed to handle high operating pressure
3. Product side is equipped with floating throttle bush
4. The seal design is unique as it closes due to the hydraulic product pressure as well overlaying barrier pressure
5. Rugged design to ensure long term reliability and operating life
6. Seals are assembled in cartridge construction for easy fitment

### Typical Industrial Applications

Chemical industry  
Suitable for all media  
Agitators

### Performance Capabilities

Shaft diameter:  $d_w = \dots 400 \text{ mm}$  ( $\dots 15.75''$ )  
Pressure:  $p_1 = \text{vacuum} \dots 60 \text{ bar}$  (870 PSI)  
Temperature:  $t = -40 \text{ }^\circ\text{C} \dots +200 \text{ }^\circ\text{C}$  ( $-40 \text{ }^\circ\text{F} \dots +392 \text{ }^\circ\text{F}$ )  
Sliding velocity:  $v_g = 0 \dots 5 \text{ m/s}$  ( $0 \dots 16 \text{ ft/s}$ )  
For applications beyond this range, please enquire.

### Materials

According to application and customer's specification

### Notes

Options:  
Cooling or heating flange  
Leakage drain, flush or heating flange  
Leakage drain or flush

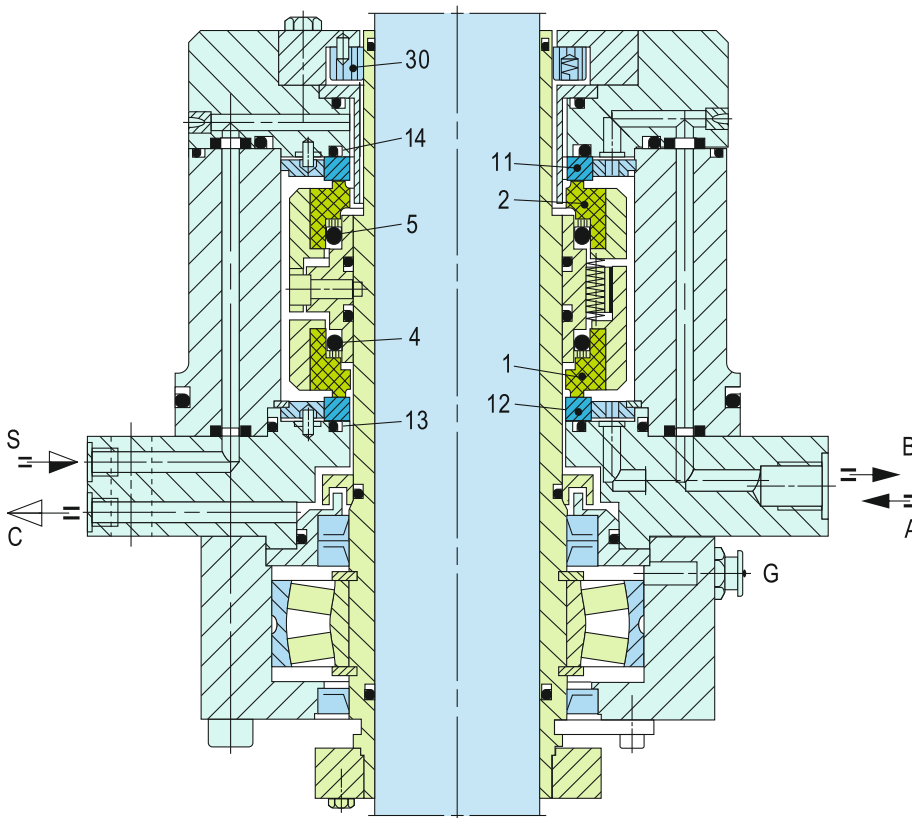

Item	Description
1	Seal face, atmosphere side
2	Seal face, product side
4, 5, 13, 14	O-ring
11	Seat, product side
12	Seat, atmosphere side
30	Throttle ring

### Installation, Details, Options

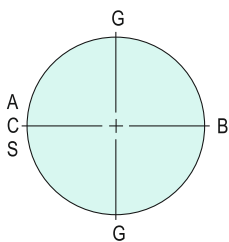

#### Supply connections

- A Barrier fluid IN
- B Barrier fluid OUT
- C Drainage
- G Grease
- S Flush

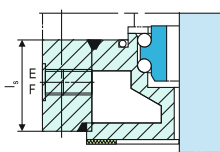

**Option**  
Cooling flange, can be used alternatively as a heating flange ( $t_{max} = 350 \text{ }^\circ\text{C}$  (662  $^\circ\text{F}$ )).

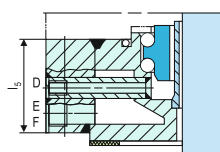

**Option**  
Leakage drain, can be used alternatively as a flush or as a heating flange.

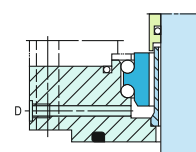

**Option**  
Leakage drain, can be used alternatively as a flush.

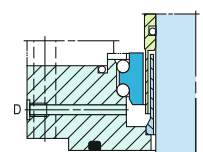

**Option**  
Polymerization barrier, can be used alternatively as a leakage drain or a flush.

The specifications, drawings, images etc included in this catalogue are intended to be generic and must be interpreted as equivalent or functionally equivalent, more specifically the performance capabilities mentioned in this catalogue is based on optimum values, however the performance of the product is dependent on size, material of construction, media, pressure, temperature, sliding velocity etc and it shall vary from size to size or application to application. Customers are requested to consult with Sealmatic before employing the product from this catalogue for any application.

## Additional Options

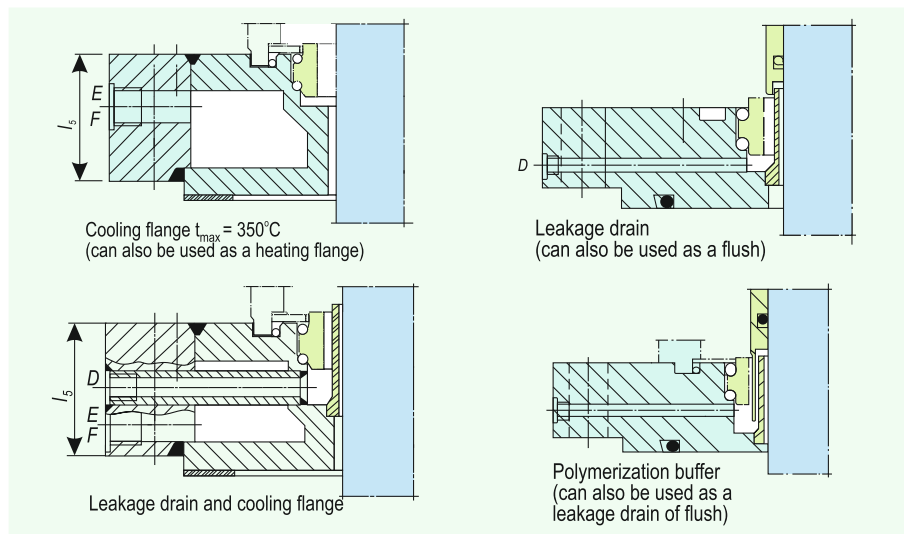

## Types Of Drive



## Code System For DIN Seals

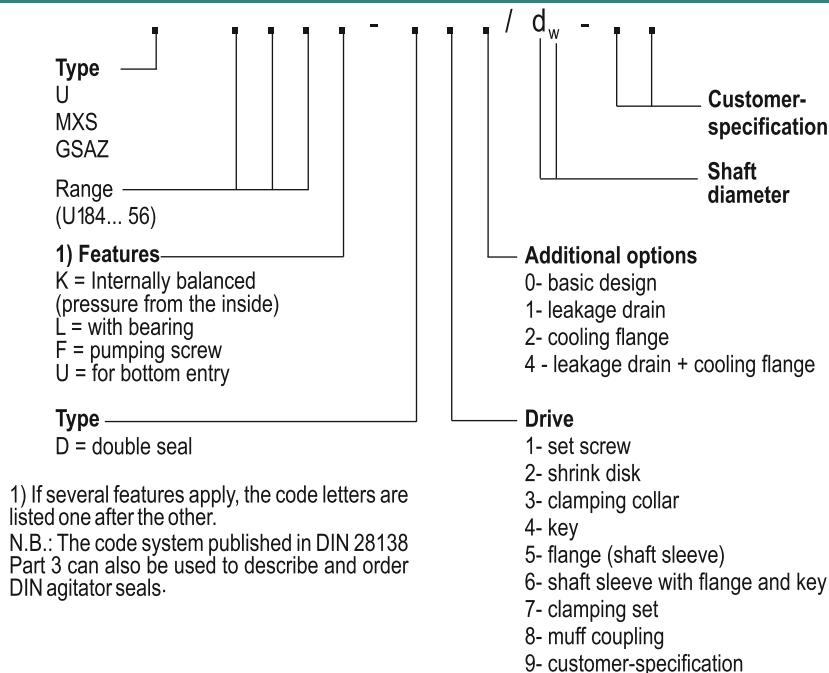

## Shut-Down Seal (Vessel Containment)

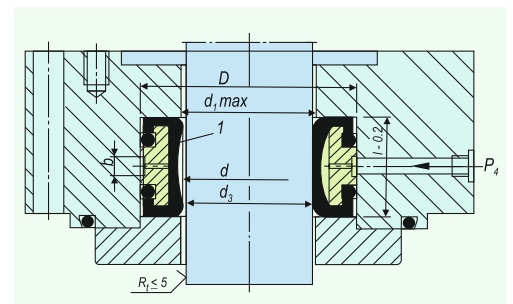

### STD1

If an STD is employed, it is possible to change seals with the vessel loaded and under pressure (shaft must be stationary!) This seal is only used if the product does not harden or congeal during the shut down period. It cannot be used if PTFE is required or for sterile operation (fermenting vessels). Can be installed in all aspects. Fitting dimensions in accordance with DIN 28138 Part 1 are possible.

### Typical Industrial Applications

Chemical industry  
Pharmaceutical industry  
Agitators  
Marine

Operating limits	$d_3$	D	d	$d_1$	l	b
$d_w = 40 \dots 200$ mm	40	76	42.5	42	38.0	8
16" .. 8"	50	84	52.5	52	38.0	8
$p_1 = 16$ bar (232 PSI)	60	95	62.5	62	44.5	10
$t = 100^{\circ}\text{C}$ (212 $^{\circ}\text{F}$ )	80	118	82.5	82	45.0	10
Elastomer sealing element (Item no. 1)	100	138	102.5	102	45.0	10
with pneumatic or hydraulic actuation	125	160	127.5	127	45.0	10
(closing pressure	140	180	143.5	143	50.0	12
$P_4 > P_1$ ).	160	200	163.5	163	50.0	12
	180	215	183.5	183	50.0	12
	200	240	203.5	203	50.0	12

## Screwed Connections

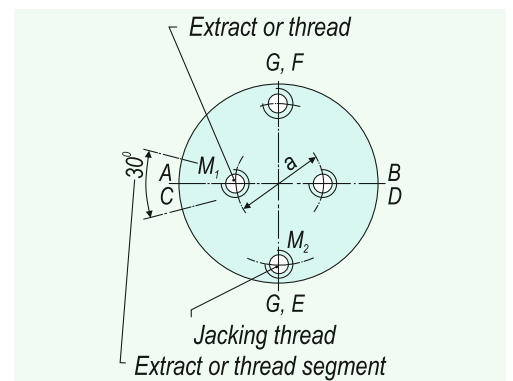

Designation and position in accordance with DIN 28138 T3.

A = Buffer fluid resp. quench IN  
B = Buffer fluid resp. quench OUT  
C = Drainage  
D = Leakage drain G1/8"  
E = Coolant IN G3/8"  
F = Coolant OUT G3/8"  
G = Grease point



### Product Description

Circulation in accordance with API 682 / ISO 21049: Plan 52, Plan 53A

The BFS6000 range of vessels range conforms to API 682 guidelines. The vessels are equipped with all essential connections for fitting additional components. The BFS 6000 system is available in standard sizes with flat ends, sight-glasses for level monitoring and with or without cooling coil. BFS 6000 system is equipped as a standard with all the necessary system connections and brackets.

### Technical Features

1. For optimum and simple cleaning of the vessel interior, a design variant is available which can be dismantled
2. Modular design combination available with a wide variety of system components and instruments selection possible, such as level switch, circulation pump, hand refill pump, thermometer, base frame etc.
3. Construction of the BFS 6000 is designed for demanding operating conditions up to 50 bar / 200°C
4. Optimum visual is achieved for level monitoring through a robust design with weld-pad type sight glass

### Typical Industrial Applications

Refining technology  
Oil and gas industry  
Chemical industry  
Petrochemical industry

### Standards

PED 2014/68/EU  
ASME VIII, Div. 1

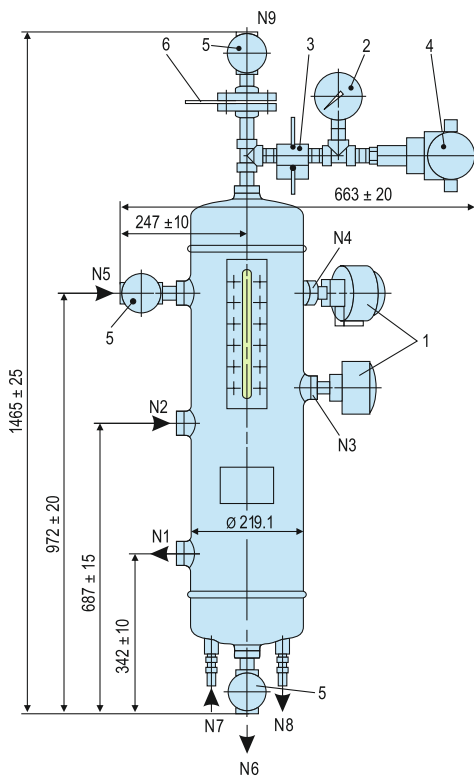

### Thermosiphon System (API Plan 52)

Item	Description
1	Level switch
2	Manometer
3	Manifold
4	Pressure switch
5	Shut-off valve
6	Orifice

### Functional Description

The BFS system performs all the basic functions of a buffer/barrier system for the operation of double seals:

- to pressurize the buffer chamber
- leakage compensation
- buffer/barrier fluid is circulated by thermosiphon effect

or forced circulation system

- to cool the seal
- to selectively absorb product leakage and prevent dry running (tandem arrangement)

Use compressed air or nitrogen for pressurization; pressurization is monitored by a pressure switch.

The incorporated level switch issues a signal whenever the level of buffer/barrier fluid is too low.

### Installation, Details, Options

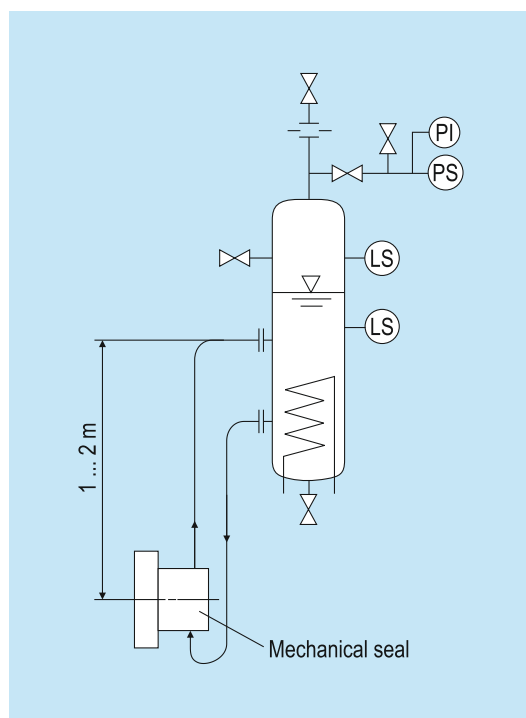

Operating and installation diagram for a BFS6000 system.

The BFS vessel must always be installed higher than the mechanical seal. The buffer/barrier fluid flows via the return pipe into the vessel and is cooled. The exchange of fluid takes place by the thermosiphon principle or by forced circulation, e.g. with a pumping screw. Connection pipes to the seal should be designed with as little resistance as possible.

### Thermosiphon System (API Plan 52)

Item	Description
N1	to the mechanical seal
N2	from the mechanical seal
N3	Level switch
N4	Level switch
N5	Filling connection
<b>Bottom</b>	
N6	Drain
N7	Cooling water IN
N8	Cooling water OUT
<b>Cover</b>	
N9	Connection to flare



### Product Description

BFS 2000 system is employed for applications in sealing systems with a wide variety of operating parameters for supplying buffer/barrier fluid to double and tandem mechanical seals. The BFS 2000 system is available in standard sizes with flat ends, sight-glasses for level monitoring and with or without cooling coil. BFS 2000 system is equipped as a standard with all the necessary system connections and brackets. Modular design combination available with a wide variety of system components and instruments selection possible such as, level switch, circulation pump, hand refill pump, thermometer, base frame etc.

Circulation in accordance with API 682 / ISO 21049: Plan 52, Plan 53A

### Technical Features

1. Available with or without cooling coil
2. Optimum draining and venting is achieved because of the design of cooling water connections at top (OUT) and bottom (IN)
3. Sockets are designed with recessed gasket to avoid contamination of the circuit by thread sealant
4. Construction of the BFS 2000 is designed for demanding operating conditions up to 30 bar / 200°C
5. Design allows for varied applications due to construction in stainless steel with borosilicate sight-glasses

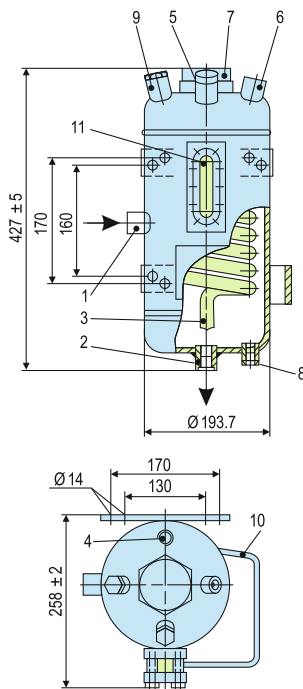

Item	Description
1	Buffer/barrier fluid IN (G1/2")
2	Buffer/Barrier fluid OUT (G1/2")
3	Cooling water IN (G1/2")
4	Cooling water OUT (G1/2")
5	Filling connection with plug (G1/2")
6	Pressure gas connection (G1/2")
7	Connection for level switch or level indicator (G2")
8	Connection for hand refill pump (G1/2")
9	Universal connection (G1/2") for safety valve, flare, etc.)
10	Bracket for hand refill pump
11	Sight-glass

Technical Features	
Designation	BFS2000
Pressure Equipment Directive	PED
Integrated cooling coil	Yes
Volume, vessel (litres)	9
Volume, tube (litres)	0.5
Allowable pressure <sup>1)</sup>	30 bar (435 PSI)
Allowable temperature <sup>1)</sup>	-60 ... +200 °C (-76 ... +392 °F)
Working volume, MAX-MIN (litres)	1.8
Cooling capacity – without cooling water (kW) <sup>2)</sup>	0.5

<sup>1)</sup> Higher values on request

<sup>2)</sup> Other materials on request

<sup>3)</sup> (Valid for thermosiphon system without cooling water with natural circulation resp. forced circulation)

### Typical Industrial Applications

Chemical industry  
 Oil and gas industry  
 Petrochemical industry  
 Refining technology

### Standards

PED 2014/68/EU (Design and production in accordance with EU Pressure Equipment Directive)  
 ASME VIII, Div.1 (Design, calculation and production)

### Functional Description

The BFS system performs all the basic functions of a buffer/barrier system for the operation of double seals:

- to pressurize the buffer chamber
- leakage compensation
- buffer/barrier fluid is circulated by thermosiphon effect or external circulation system
- to cool the seal
- to selectively absorb product leakage and prevent dry running (tandem arrangement)
- Use compressed air or nitrogen for pressurization.

### Operating and Installation Schematic

The BFS vessel must always be installed higher than the mechanical seal. The buffer/barrier fluid flows via the return pipe into the vessel and is cooled. The exchange of fluid takes place by the thermosiphon principle or by forced circulation, e.g. with a pumping screw. Connection pipes to the seal should be designed with as little resistance as possible.

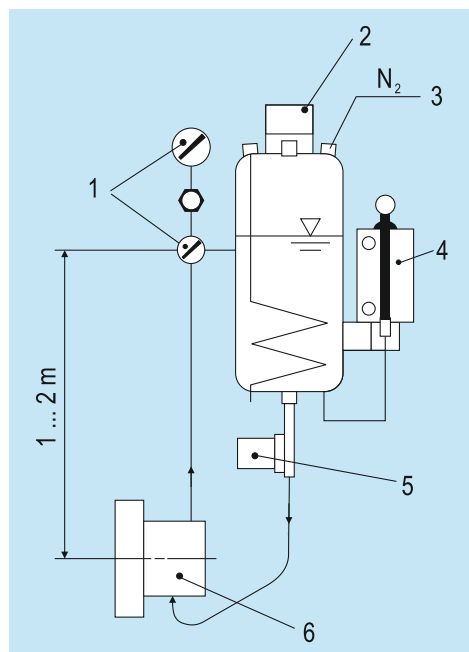

1. Measuring unit
2. Level Switch
3. From PCV, we recommend using a reverse controlled pressure control valve (PCV)
4. Hand Refill Pump
5. Circulating Pump
6. Mechanical seal





### Product Description

Circulation in accordance with API 682 / ISO 21049: Plan 52, Plan 53A  
 BFS1016 system is employed for applications in sealing systems with a wide variety of operating parameters for supplying buffer/barrier fluid to double and tandem mechanical seals. The BFS1016 system is available in standard sizes with flat ends, sight-glasses for level monitoring and with or without cooling coil. BFS1016 system is equipped as a standard with all the necessary system connections and brackets.

### Technical Features

1. Available with or without cooling coil
2. All connections of the systems are side faced
3. Compact design of the system allows low space requirements
4. Modular design combination available with a wide variety of system components and instruments selection possible such as, level switch, circulation pump, hand refill pump, thermometer, base frame etc.
5. Design allows for varied applications due to construction in stainless steel with borosilicate sight-glasses

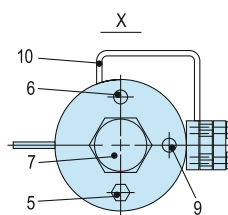
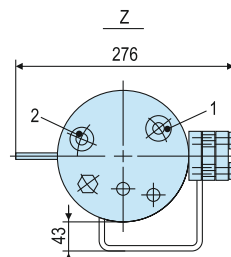
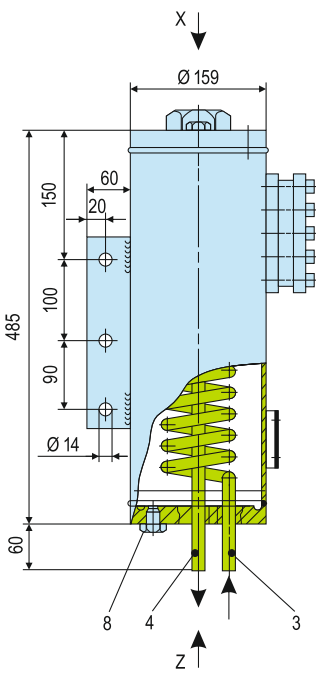

Item	Description
1	Buffer/barrier fluid IN (G1/2")
2	Buffer/barrier fluid OUT (G1/2")
3	Cooling water IN (pipe 12 x 1.5 mm)
4	Cooling water OUT (pipe 12 x 1.5 mm)
5	Filling connection with cap (G1/2")
6	Pressure gas connection (1/4" NPT)
7	Connection for level switch (G2")
8	Connection for refill unit (G1/8")
9	Connection for pressure gauge (1/4"NPT)
10	Bracket for refill unit

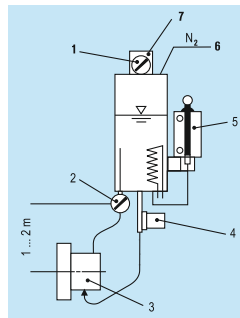

### Technical Features

Designation	BFS1016	BFS1010
Pressure Equipment Directive	PED	PED
Integrated cooling coil	Yes	No
Volume of vessel (litres)	8	10
Volume of tube (litres)	0.2	-
Allowable pressure <sup>1)</sup>	16 bar (232 PSI)	16 bar (232 PSI)
Allowable temperature <sup>1)</sup>	-60°C ... +200°C (-76°F ... +392°F)	0°C ... +90°C (32°F ... +194°F)
Working volume, MAX-MIN (litres)	1.3	1.8
Cooling capacity – without cooling water (kW) <sup>3)</sup>	0.3	-
Cooling capacity – natural circulation (kW) <sup>2)</sup>	1.2	-
Cooling capacity – forced circulation (kW) <sup>2)</sup>	2.5	-
Required cooling water quantity (m <sup>3</sup> /h)	0.3	-
Metal parts	1.4571	1.4301
Sight-glass	Reflex sight-glass Borosilicate	-
Seal	PTFE	-

Other versions on request.

<sup>1)</sup> Technical details of BFS1010 will be available on request

<sup>2)</sup> Guidelines with buffer/barrier fluid water 60 °C – cooling water 20 °C

<sup>3)</sup> Guidelines with buffer/barrier fluid water 60 °C – ambient temperature 20 °C (valid for thermosiphon systems without cooling water with natural circulation resp. forced circulation)

The specifications, drawings, images etc included in this catalogue are intended to be generic and must be interpreted as equivalent or functionally equivalent, more specifically the performance capabilities mentioned in this catalogue is based on optimum values, however the performance of the product is dependent on size, material of construction, media, pressure, temperature, sliding velocity etc and it shall vary from size to size or application to application. Customers are requested to consult with Sealmatic before employing the product from this catalogue for any application.

### Typical Industrial Applications

- Chemical industry
- Petrochemical industry
- Pulp and paper industry
- Food processing industry
- Water and waste water technology

### Functional description

The BFS system performs all the basic functions of a buffer/barrier system for the operation of double seals:

- to pressurize the buffer chamber
  - leakage compensation
  - buffer/barrier fluid is circulated by thermosiphon effect or forced circulation system
  - to cool the seal
  - to selectively absorb product leakage and prevent dry running (tandem arrangement)
- Use compressed air or nitrogen for pressurization.

### Standards

PED 2014/68/EU (Design and production in accordance with EU Pressure Equipment Directive)

### Installation, Details, Options

Operating and installation diagram for a BFS1016 system.

The BFS vessel must always be installed higher than the mechanical seal. The buffer/barrier fluid flows via the rising pipe into the vessel and is cooled. Particularly with natural circulation, the fluid level must always be higher than the rising pipe to maintain the circulation and to provide the specified cooling capacity. Connection pipes to the seal should be designed with as little resistance as possible.

- 1 Pressure gauge
- 2 Thermometer
- 3 Mechanical seal
- 4 Circulating Pump
- 5 Hand Refill Pump
- 6 From PCV, we recommend using a reverse controlled pressure control valve (PCV)
- 7 Level switch



### Product Description

CPU5000 is a radial screw pump. The ideal field of application are closed high pressure circuits in process hydraulic systems. For this purpose, the CPU5000 is an inexpensive alternative to glandless centrifugal pumps. The CPU5000 pumps are not self-priming, which means that the pump circuit must be well vented.

### Technical Features

The CPU circulating pump is employed for circulating buffer/barrier fluid in seal supply systems (to increase the cooling capacity). The CPU is suitable for water and other liquids of similarly low viscosity.

### Advantages

- CPU5000: Hermetically sealed, magnetically coupled and maintenance-free pump.

### Recommended application

- Petrochemical industry
- Chemical industry
- Oil and gas industry
- Refining technology
- Food and beverage industry
- Pharmaceutical industry

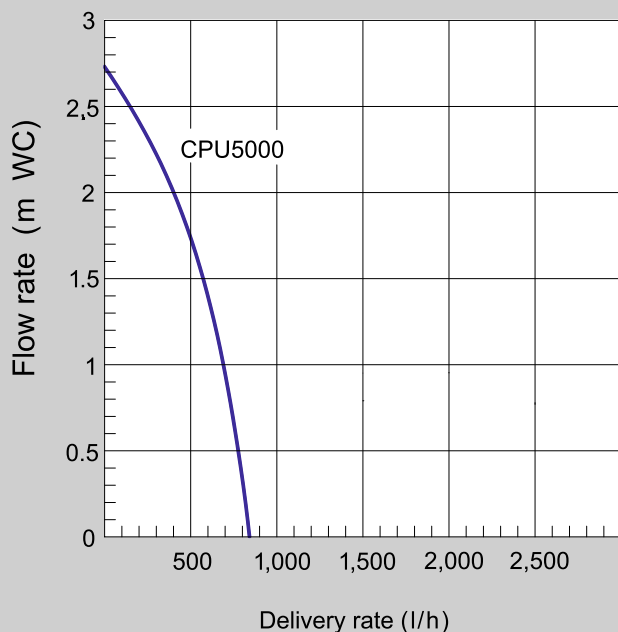

### Technical Features

Type Of Seal	Magnetic Coupling
Max. Allowable Viscosity (mm <sup>2</sup> /s)	15
Max. Working Pressure	40 bar (580 PSI)
Max. Working Temperature	95 °C (203 °F)
Ingress Of Protection	IP 55
Supply Voltage	400 V / 50 Hz 230 V / 50 Hz
Power Consumption (W)	120 W
Material	1.4401 / Viton / IGLIDUR

The specifications, drawings, images etc included in this catalogue are intended to be generic and must be interpreted as equivalent or functionally equivalent, more specifically the performance capabilities mentioned in this catalogue is based on optimum values, however the performance of the product is dependent on size, material of construction, media, pressure, temperature, sliding velocity etc and it shall vary from size to size or application to application. Customers are requested to consult with Sealmatic before employing the product from this catalogue for any application.



### Product Description

Circulation in accordance with API 682 / ISO 21049: Plan 53C

PBS system is employed for applications in sealing systems with a wide variety of operating parameters for supplying quench buffer fluid to double and tandem mechanical seals. PBS system is equipped as a standard with all the necessary system connections and brackets. Modular design combination available with a wide variety of system components.

The maximum operating pressure of the PBS system applies to the housing of the pressure booster, i.e. the process/medium pressure at the connection must be lower and is conditional on the transmission ratio

### Technical Features

1. Simple and reliable operation is achieved due to automatic setting of the barrier pressure through reference pressure
2. Barrier pressure is achieved without any need for connection to a nitrogen supply source
3. Hassle free maintenance of simple and quick cleaning is achieved in operation as the housing can be dismantled
4. Modular design combination available with a wide variety of system components possible
5. Optimum level of monitoring is achieved due to the protective pipe made in borosilicate glass
6. Safe operation even in case of pressure changes
7. Sockets are designed with recessed gasket to avoid contamination of the circuit by thread sealant

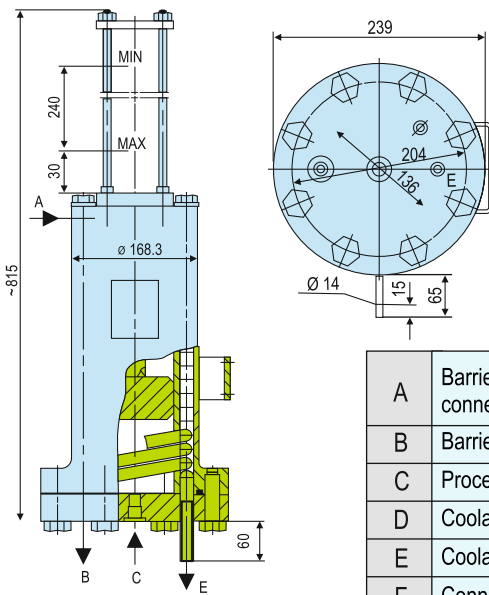

A	Barrier medium IN (G1/2") connection possible for Measuring unit
B	Barrier medium OUT (G1/2")
C	Process medium (G1/2")
D	Coolant IN (tube 15 x 1.5)
E	Coolant OUT (tube 15 x 1.5)
F	Connection for HRP (G1/8")

### Recommended applications

Refining technology  
Oil and gas industry  
Chemical industry  
Petrochemical industry

### Standards

PED 2014/68/EU (Design and production in accordance with EU Pressure Equipment Directive) ASME VIII, Div. 1 (Design, calculation and production)

### Functional Description

The function of the PBS system is similar in principle to the BFS system. The difference is that the barrier pressure is created by the reference pressure without any additional superimposition of nitrogen. The pressure booster is for storing and cooling the barrier fluid. Pressurization is by means of a piston in dependency on the process/medium pressure. Automatic pressure increase in accordance with the transmission ratio.

### Installation, Details, Options

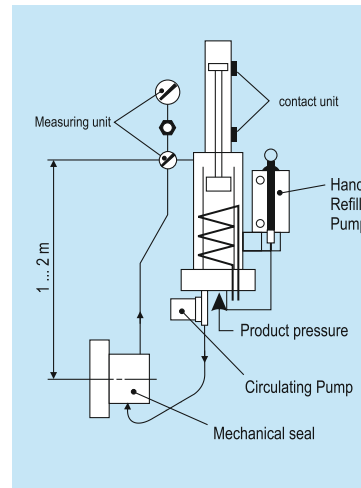

Operating and installation diagram for a PBS system. The PBS pressure booster must always be installed higher than the mechanical seal. The barrier fluid flows via the return pipe into the vessel and is cooled. The exchange of fluid takes place by the thermosiphon principle or by forced circulation, e.g. with a pumping screw. Connection pipes to the seal should be designed with as little resistance as possible.

### Technical Features

Designation	PBS2000
Pressure Equipment Directive	PED
Integrated cooling coil	Yes
Transmission ratio	1:1.1
Volume, jacket (litres)	4
Volume, cooling coil (litres)	0.7
Allowable pressure <sup>1)</sup>	63 bar (913 PSI)
Allowable process/medium pressure at connections C <sup>1)</sup>	57 bar (827 PSI)
Allowable working temperature <sup>1)</sup>	-60 °C ... +200 °C (-76 °F ... +392 °F)
Working volume, MAX-MIN (litres)	2
Cooling capacity – without cooling water (kW) <sup>3)</sup>	0.5
Cooling capacity – natural circulation (kW) <sup>3)</sup>	1.5
Cooling capacity – forced circulation (kW) <sup>2)</sup>	4
Required cooling water quantity (m <sup>3</sup> /h)	0.4
Metal parts	1.4571
Protective tube for piston rod	Borosilicate
Seal	PTFE
Net weight (approx.)	51 kg (112 lb)

Other versions on request.

<sup>1)</sup> Design data, permissible working values depend on the actual conditions of service

<sup>2)</sup> Guidelines with barrier fluid water 60 °C – cooling water 20 °C

<sup>3)</sup> Guidelines with barrier fluid water 60 °C – ambient temperature 20 °C

(valid for pressure booster systems without cooling water with natural circulation resp. forced circulation)

The specifications, drawings, images etc included in this catalogue are intended to be generic and must be interpreted as equivalent or functionally equivalent, more specifically the performance capabilities mentioned in this catalogue is based on optimum values, however the performance of the product is dependent on size, material of construction, media, pressure, temperature, sliding velocity etc and it shall vary from size to size or application to application. Customers are requested to consult with Sealmatic before employing the product from this catalogue for any application.



**Product Description**

Circulation in accordance with API 682 / ISO 21049: Plan 53B  
 Pressurised barrier system (closed circuit) is employed for applications in sealing systems with operating parameters of high pressures and/or for hazardous/environmentally harmful processes. The BFS (Plan 53B) range is available with a pressure accumulator, cooler (finned tube or water or air cooler with fan) with a wide range of instruments.

**Technical Features**

1. Design construction available with finned tube, water or air coolers with fan
2. Barrier pressure is created without any need for connection to a nitrogen supply
3. Modular design combination available with a wide variety of system components and instruments selection possible
4. Pressurisation is achieved through a pre-loaded bladder accumulator
5. Nitrogen cannot get into the barrier medium or process medium, because it is separated from the barrier medium by membranes in the accumulator

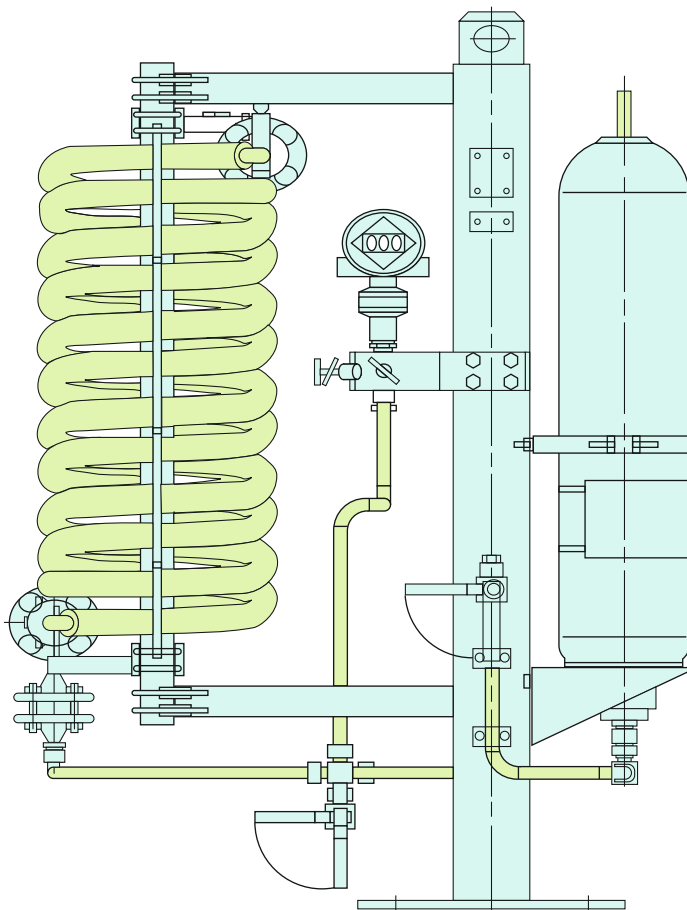

**Typical Industrial Applications**

- Chemical industry
- Oil and gas industry
- Petrochemical industry
- Refining technology

**Functional Description**

The BFS is designed to perform the following functions of a barrier system:

- to pressurize the barrier chamber
- leakage compensation
- to cool the seal

Pressurization (> process pressure) prevents the process medium from getting into the barrier circuit or the atmosphere. Pressurization is supplied by a pressure accumulator which is pre-loaded with nitrogen. Circulation in the barrier circuit takes place by the thermosiphon principle or by forced circulation, e.g. with a pumping screw.

**Standards**

- PED 2014/68/EU (Design and production in accordance with EU Pressure Equipment Directive)
- ASME VIII, Div. 1 (Design, calculation and production)

**Installation, Details, Options**

**Operating and installation diagram for a BFS (Plan 53B).**

- A From mechanical seal
- B To mechanical seal
- C Fill
- F Drain
- G Vent
- H N2 Precharge

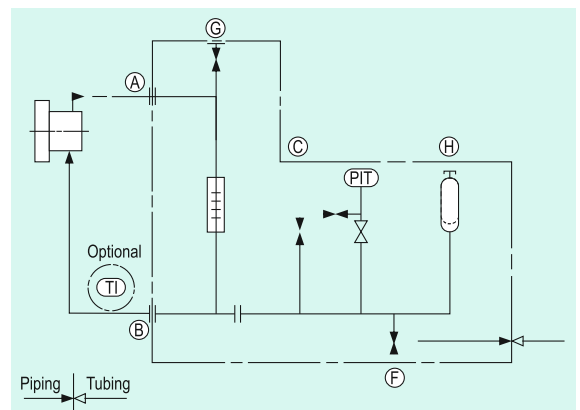

The specifications, drawings, images etc included in this catalogue are intended to be generic and must be interpreted as equivalent or functionally equivalent, more specifically the performance capabilities mentioned in this catalogue is based on optimum values, however the performance of the product is dependent on size, material of construction, media, pressure, temperature, sliding velocity etc and it shall vary from size to size or application to application. Customers are requested to consult with Sealmatic before employing the product from this catalogue for any application.

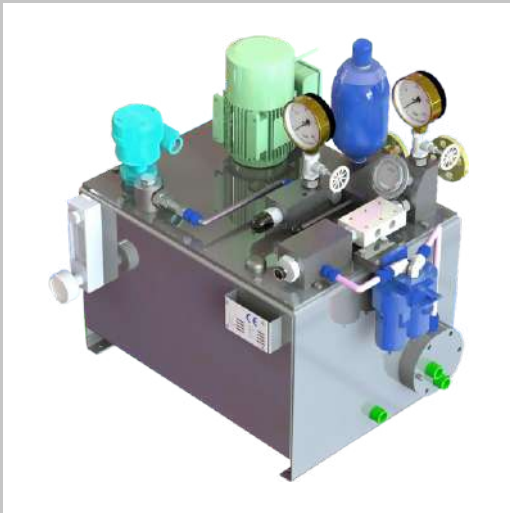

### Product Description

BFS range of barrier pressure units are designed to perform various functions of a barrier system which is essential for operating double seals (circulation and cooling of the barrier medium, pressurisation of the barrier fluid and compensation of leakage). The BFS systems are designed to operate with hydraulic oil having viscosity values ranging from 12 to 90 mm<sup>2</sup>/s under normal operating temperature of the equipment. The final selection of optimum viscosity of the oil to be used has to be ascertained independently in accordance with the respective operating parameters of the equipment.

### Technical Features

1. For reducing barrier fluid pressure at standstill an automatic relief valve is provided
2. Reversible double filter is provided for the fluid to pass through the oil cooler
3. Level Switch with contact for minimum level
4. Barrier fluid pressure can be controlled manually
5. Maximum operating temperature in the tank to be maintained at 80 °C (return line maximum 90 °C)
6. For monitoring the pump discharge pressure (outside the circuit) an additional pressure connection is provided
7. Temperature monitoring is achieved by providing a return line and tank thermometer

### Typical Industrial Applications

Chemical industry  
Oil and gas industry  
Petrochemical industry  
Refining technology

### Functional Description

The barrier pressure for circulation is generated by a gear pump. The setpoint barrier pressure is set on an overflow valve in the mechanical seal return line. From this point on the barrier fluid flows back without pressure through a filter and a heat exchanger to the storage tank. To enable systems (pump, agitator) to be stopped without causing damage to the seal in the event of a malfunction (e.g. power failure, damaged motor, etc.), the barrier pressure unit can be fitted with a pressure accumulator unit. To prevent the pressure in the accumulator discharging to the pressureless storage tank, the return line has a pilot-operated check valve, and the supply line also has a simple check valve. The barrier pressure is retained for a limited time. However, no circulation takes place and no heat is dissipated from the mechanical seal.

### Technical Features

Designation	Nominal pressure max. Barrier pressure	Flow rate (l/min)	Cooling capacity (kW) with hydraulic oil $\Delta t = 10K$	Tank		Dimensions overall (mm)			Net weight approx.	Motor data
				Nominal capacity (litres)	Circulation volume (litres)	Height	Width	Depth		
BFS 54	40 bar (580 PSI)	6	1.8	40	12	650	610	380	125	1

Higher values on request  
Other materials on request

### Installation, Details, Options

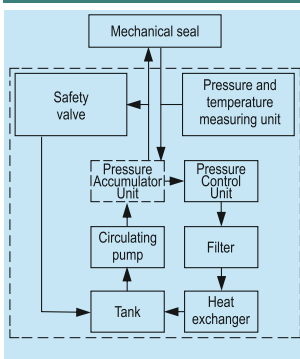

Installation and operating diagram for a BFS system.

The specifications, drawings, images etc included in this catalogue are intended to be generic and must be interpreted as equivalent or functionally equivalent, more specifically the performance capabilities mentioned in this catalogue is based on optimum values, however the performance of the product is dependent on size, material of construction, media, pressure, temperature, sliding velocity etc and it shall vary from size to size or application to application. Customers are requested to consult with Sealmatic before employing the product from this catalogue for any application.



### Product Description

Circulation in accordance with API 682 / ISO 21049: Plan 21, Plan 22, Plan 23, Plan 41

HED designed heat exchanger is employed to cool process/barrier fluids in seal supply systems.

Construction of the vessel is in a tubular design with integrated guide plates, the process/barrier medium is directed through the shell of the HED and the cooling medium through the tubes.

### Technical Features

1. Cooling capacity up to 36 kW
2. Installation can be done either in a vertical or a horizontal position
3. For optimum and simple cleaning, the heat exchanger can be dismantled
4. Compact design of tubular heat exchanger with integrated guide plates along with extremely efficient cooling capacity
5. Designed for varied applications due to construction in stainless steel allows flush with a suitable solvent on the process/barrier medium side

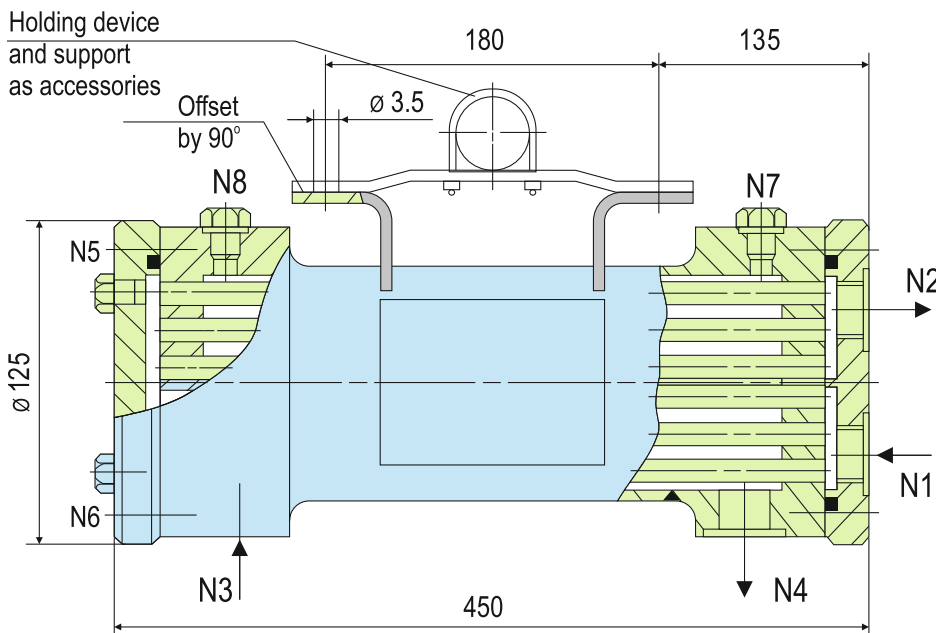

### Typical Industrial Applications

Chemical industry  
Oil and gas industry  
Petrochemical industry  
Power plant technology  
Refining technology

### Notes

Cleaning:  
Cooling water side: the area around the tubes can be cleaned mechanically after the housing is removed.  
Process/barrier medium side: flush with a suitable solvent.

### Standards

PED 2014/68/EU (Design and production in accordance with EU Pressure Equipment Directive)  
ASME VIII, Div. 1 (Design, calculation and production)

Connections	
Item	Description
N1	Cooling water IN
N2	Cooling water OUT
N3	Process/barrier medium IN
N4	Process/barrier medium OUT
N5	Cooling circuit vent
N6	Cooling water drain
N7/N8	Process/barrier circuit vent

Other versions on request.

<sup>1)</sup> These values are based on the calculation of strength.

<sup>2)</sup> These values are based on the calculation of heat.

<sup>3)</sup> Related to water on both sides

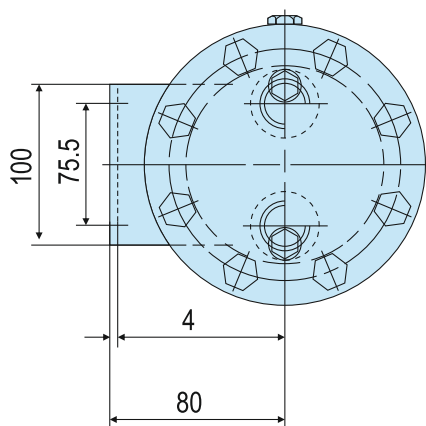

### Technical Features

Designation HED	Tubes	Shell
Pressure Equipment Directive	PED	
Allowable pressure <sup>1)</sup>	16 bar (232 PSI)	130 bar (1885 PSI)
Allowable temperature <sup>1)</sup>	150 °C (302 °F)	
Inlet temperature <sup>2)</sup>	30 °C (86 °F)	65 °C (149 °F)
Flow quantity (m <sup>3</sup> /h) <sup>3)</sup>	1	approx. 0.5
Volume (litres)	0.23	1.4
Cooling surface <sup>3)</sup>	0.2	
Cooling capacity (kW) <sup>3)</sup>	6	
Metal parts	SS 316	
O-rings	FKM	
Gaskets	PTFE	
Screws	Stainless steel A4-70	

The specifications, drawings, images etc included in this catalogue are intended to be generic and must be interpreted as equivalent or functionally equivalent, more specifically the performance capabilities mentioned in this catalogue is based on optimum values, however the performance of the product is dependent on size, material of construction, media, pressure, temperature, sliding velocity etc and it shall vary from size to size or application to application. Customers are requested to consult with Sealmatic before employing the product from this catalogue for any application.



### Product Description

Available with a wide range of different instruments for safe operation due to the incorporated pressure regulator with integrated filter system mounted on a plate or in housing. For operating pressures up to 12 bar (174 PSI).

### Technical Features

Gas supply systems GPS are specially designed for contact-free operation for gas-lubricated mechanical seals. The gas supplied from the supply network (e.g., air or nitrogen) is regulated/monitored by the GPS in accordance with the requirements of the gas seals. The GPS systems are equipped with alarm and/or switch-off points depending on specific safety requirements. Circulation in accordance with API 682 / ISO 21049: Plan 74

### Functional Description

GPS is a pressurize plan 74 which uses gas (e.g. Nitrogen) as a barrier medium for gas lubricated mechanical seals. The barrier gas pressure,  $p_3$  must always be higher than the medium pressure,  $p_1$ . For individual seal types, the minimum pressure difference ( $\Delta p$ ) is specified separately.

### Main GPS functions

- Filtering of barrier gas
- Pressure monitoring and regulation
- Flow monitoring

### Typical tasks for the GPS

- Barrier gas supply for double seals
- Gas flushing for single seals
- Gas supply for tandem seals

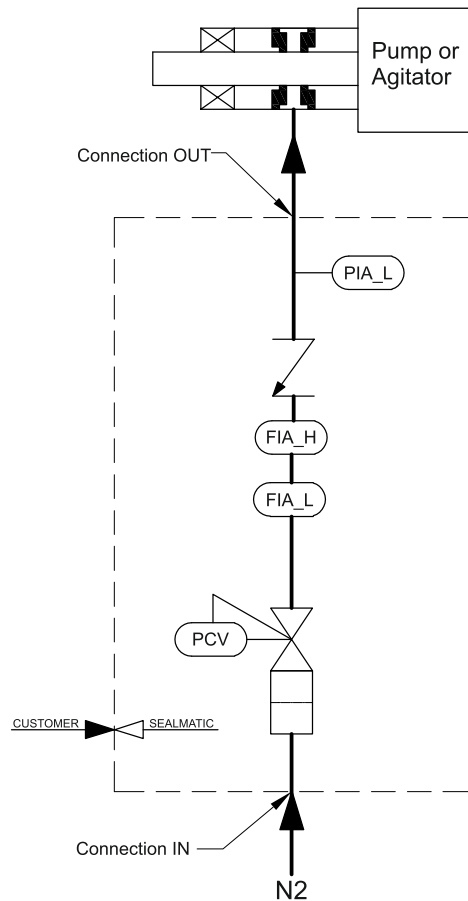

- PCV : Pressure control value
- FIA\_L : Flow meter with MIN Contact
- FIA\_H : Flow meter with MAX Contact
- PIA\_L : Pressure Gauge

**Note:** To assure a sufficient supply of the mechanical seal, pressure at entry of the supply system must be min. 2 bar (29 PSI) above max. barrier pressure always.

The specifications, drawings, images etc included in this catalogue are intended to be generic and must be interpreted as equivalent or functionally equivalent, more specifically the performance capabilities mentioned in this catalogue is based on optimum values, however the performance of the product is dependent on size, material of construction, media, pressure, temperature, sliding velocity etc and it shall vary from size to size or application to application. Customers are requested to consult with Sealmatic before employing the product from this catalogue for any application.

### Advantages

- GPS System mounted in a housing or can be mounted on a plate
- Different instruments with wide scope available for safe operation

### Recommended application

- Chemical industry
- Petrochemical industry
- Power plant technology
- Refining technology
- Oil and gas industry

### Technical Data

Designation	GPS
Max. Operating Pressure	12 bar (174 PSI)
Max. Operating Temperature	60°C
Medium	Nitrogen / Air



**Product Description**

Circulation in accordance with API 682 / ISO 21049: Plan 21, Plan 22, Plan 23, Plan 41  
 HE designed heat exchanger is used to cool process/barrier fluids in seal supply systems. HE heat exchanger is available in standard construction and conforms to API 682 standards.  
 The process/barrier medium is directed through the tube and the cooling medium through the shell. For simple draining or venting on the side of the cooling water, the heat exchanger can also be supplied with ventilation/drainage ball valves. Temperature instruments can also be fitted in the supply line of the mechanical seals.

**Technical Features**

1. Construction design for operating pressure up to 45 bar / 260°C (tube side)
2. Design allows for varied applications due to construction in stainless steel
3. For optimum and simple cleaning of the tubes, the heat exchanger can be dismantled
4. Complete venting and draining of the cooling water side and process can be achieved

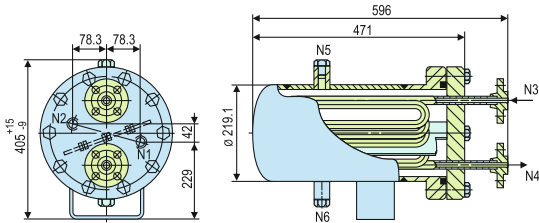

**Typical Industrial Applications**

Chemical industry  
 Oil and gas industry  
 Petrochemical industry  
 Refining technology

**Notes**

Cleaning:  
 Cooling water side: the area around the tubes can be cleaned mechanically after the housing is removed. Process/barrier medium side: flush with a suitable solvent.

**Standards**

PED 2014/68/EU (Design and production in accordance with EU Pressure Equipment Directive)  
 ASME VIII, Div. 1 (Design, calculation and production)

**Technical Features**

Designation	HE	
	Tube	Shell
Pressure Equipment Directive	ASME	
For shaft diameters > 60 mm (acc. to API682)	x	
Ball valve for draining on the cooling water side	-	
Connections	3/4" flange	3/4" NPT
Design pressure <sup>1)</sup>	45 bar (653 PSI)	16 bar (232 PSI)
Design temperature <sup>1)</sup>	260 °C (500 °F)	150 °C (302 °F)
Cooling capacity (kW) <sup>1)</sup>	6	
Metal parts	1.4404	
O-rings	FKM	
Screws	Stainless steel A4-70	

Other versions on request.

<sup>1)</sup> These values are based on the calculation of strength.

<sup>2)</sup> Related to water on both sides

The specifications, drawings, images etc included in this catalogue are intended to be generic and must be interpreted as equivalent or functionally equivalent, more specifically the performance capabilities mentioned in this catalogue is based on optimum values, however the performance of the product is dependent on size, material of construction, media, pressure, temperature, sliding velocity etc and it shall vary from size to size or application to application. Customers are requested to consult with Sealmatic before employing the product from this catalogue for any application.





### Product Description

Circulation in accordance with API 682 / ISO 21049: Plan 21, Plan 22, Plan 23, Plan 41

HEK designed heat exchanger is employed to cool process/barrier fluids in seal supply systems. The heat exchanger has a wound double helix around the guide tube, the process/barrier medium is directed through the shell of the HEK and the cooling medium through the tubes.

### Technical Features

1. Cooling capacity up to 10.5 kW
2. Cost effective solution
3. Effective cooling achieved with wound double helix around a guide tube
4. Designed for varied applications due to construction in stainless steel
5. For optimum and simple cleaning, the heat exchanger can be dismantled

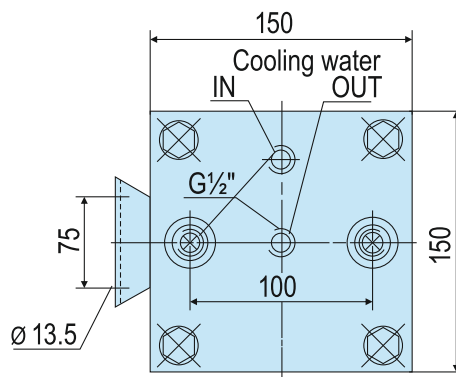
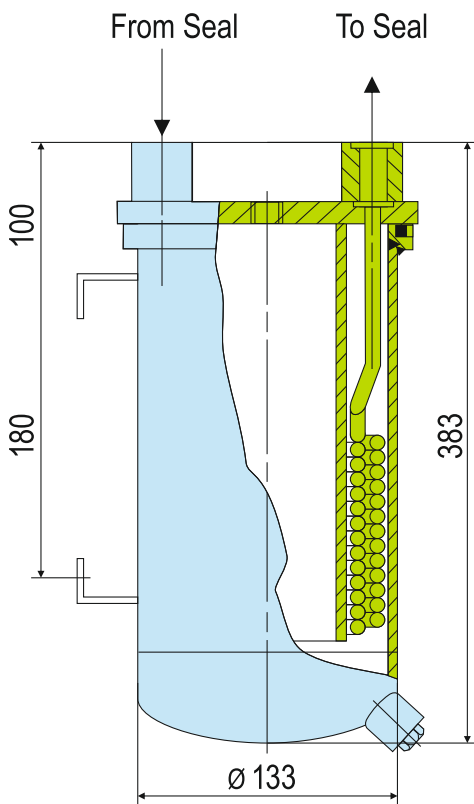

### Typical Industrial Applications

Chemical industry  
Petrochemical industry  
Power plant technology  
Refining technology  
Oil and gas industry

### Standards

PED 2014/68/EU (Design and production in accordance with EU Pressure Equipment Directive)

### Notes

Mount vertically with connections pointing up. Provide for external venting on the process/barrier medium side (the user has to install a vent at the highest point of the pipe work).

Cleaning:  
Cooling water side: the area around the tubes can be cleaned mechanically after the housing is removed.  
process/barrier medium side: flush with a suitable solvent.

### Technical Features

Designation HEK	Tube	Shell
Pressure Equipment Directive	PED	
Allowable pressure <sup>1)</sup>	120 bar (1740 PSI)	16 bar (232 PSI)
Allowable temperature <sup>1)</sup>	160 °C (320 °F)	95 °C (203 °F)
Inlet temperature <sup>2)</sup>	70 °C (158 °F)	25 °C (77 °F)
Flow rate <sup>2)</sup>	10 l/min	1.8 m <sup>3</sup> /h
Volume (litres)	0.34	1.13
Cooling surface <sup>3)</sup>	0.3 m <sup>2</sup>	
Cooling capacity (kW)	10.5	
Metal parts	SS 316	Carbon steel, primed on the outside
Seals		FKM
Screws		Stainless steel A4-70

Other versions on request.

<sup>1)</sup> These values are based on the calculation of strength.

<sup>2)</sup> These values are based on the calculation of heat.



**Product Description**

MS range of separators consists of a pressure casing with integrated magnetic rod for high level of efficiency. MF filters are employed in seal supply systems and any other such systems in which the media has to be cleaned of magnetic impurities up to a certain size

**Technical Features**

1. Construction design for operating pressure up to 150 bar
2. Hassle free maintenance of simple and quick cleaning is achieved in operation as the housing can be dismantled
3. Reliability in operation due to rugged technology

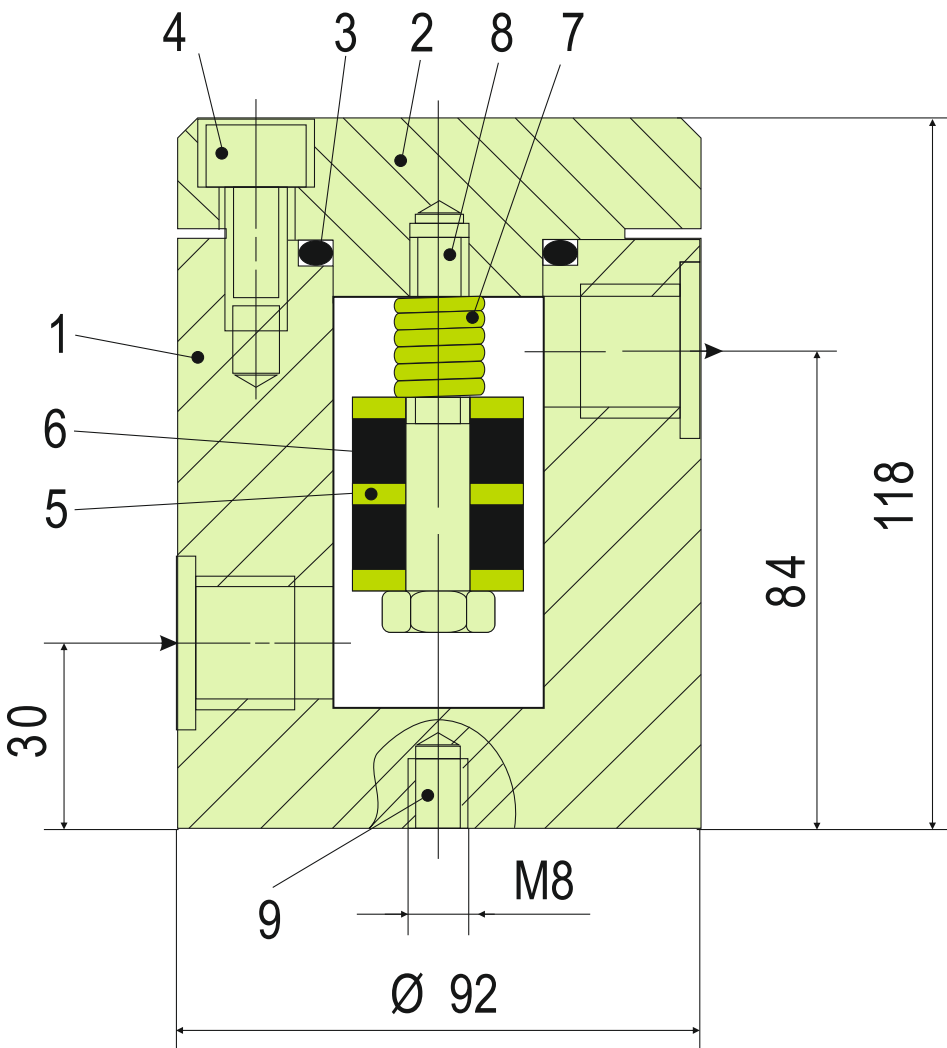

**Typical Industrial Applications**

- Chemical industry
- Oil and gas industry
- Petrochemical industry
- Power plant technology
- Refining technology

**Functional Description**

The magnetic rod is positioned in the casing in such a way that it catches magnetic particles flowing past in the medium on all sides.

**Operating and Installation Schematic**

**Cleaning:**

The magnetic rod can be removed for cleaning with the casing fitted by opening the cover (with the line depressurized!). Maintenance intervals depend on the degree of soiling. We recommend checking and if necessary cleaning the magnetic rod several hours after using for the first time and each time after flushing the pipes because experience indicates that much of the dirt is flushed out of the pipes at this time.

Item	Description
1,2	Casing and cover
3	O-ring
4,8	Screws
5	Washers
6	Ring magnets: corrosion-resistant
7	Spring
8	Fixing hole

**Technical Features**

Description	Connection	Allowable pressure	Allowable temperature	Volume (litres)	weight approx.	Cover, housing	Spring	O-ring	Gasket
MS	G 1/2"	120 bar (1,740 PSI)	160 °C (320 °F)	0.08	5.5 kg. 12.2 lbs	Stainless Steel	1.4301	EPDM	T2

Other variants on request

The specifications, drawings, images etc included in this catalogue are intended to be generic and must be interpreted as equivalent or functionally equivalent, more specifically the performance capabilities mentioned in this catalogue is based on optimum values, however the performance of the product is dependent on size, material of construction, media, pressure, temperature, sliding velocity etc and it shall vary from size to size or application to application. Customers are requested to consult with Sealmatic before employing the product from this catalogue for any application.



**Product Description**

MF filters are inline filters for installation inside pipelines and are employed in seal supply systems and any other such systems in which the media has to be cleaned of magnetic and non-magnetic impurities up to a certain size. High level of efficiency is guaranteed because of the combination of magnetic rod and filter element

**Technical Features**

1. All the parts exposed to pressure are constructed from forged material
2. Combination device: magnetic filter and filter element
3. Hassle free maintenance of simple and quick cleaning is achieved in operation as the housing can be dismantled
4. Protection of filter elements from reverse current is achieved due to the provision of internal mesh
5. Venting screws in the filter inlet and outlet can be employed as connections for maintenance or for indicating differential pressure

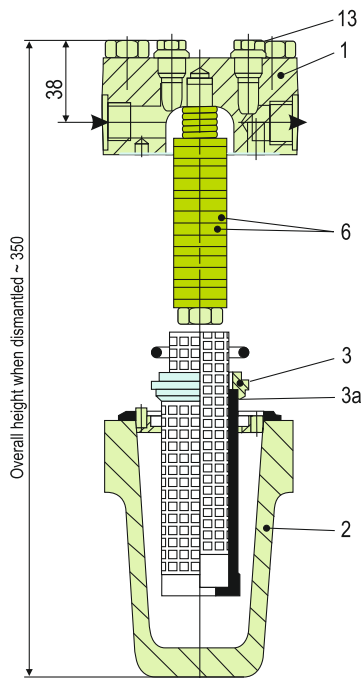

**Typical Industrial Applications**

- Chemical industry
- Oil and gas industry
- Petrochemical industry
- Power plant technology
- Refining technology

**Functional Description**

The magnetic rod is positioned in the filter in such a way that it catches magnetic particles flowing past in the medium on all sides. Partial coarse filtration is provided by the incorporated filter element.

Item	Description
1	Filter cover
2	Filter barrel
3	Element insert
3a	Internal mesh
6	Ring magnet
13	Venting screw

**Technical Features**

Designation	Connection	Allowable pressure	Allowable temperature <sup>1)</sup>	Filter grade	Weight (approx.)	Housing, filter head	Filter insert, filter element <sup>2)</sup>	O-ring	Gasket
MF	G 1/2"	63 bar (913 PSI)	150 °C (302 °F)	50 µm	7.8 kg (17.2 lb)	1.4571	1.4301	FKM	T2

<sup>1)</sup> Higher values on request

<sup>2)</sup> Other materials on request

The specifications, drawings, images etc included in this catalogue are intended to be generic and must be interpreted as equivalent or functionally equivalent, more specifically the performance capabilities mentioned in this catalogue is based on optimum values, however the performance of the product is dependent on size, material of construction, media, pressure, temperature, sliding velocity etc and it shall vary from size to size or application to application. Customers are requested to consult with Sealmatic before employing the product from this catalogue for any application.



**Product Description**

Circulation in accordance with API 682 / ISO 21049: Plan 31, Plan 41  
 The CS range is available in varied versions i.e. cyclone separator with replaceable insert made of ceramic or cast version of the cyclone separator or cyclone separator for high flow rates and high pressures.

**Technical Features**

1. Construction design for operating pressure up to 200 bar
2. Hassle free maintenance is achieved in operation with high reliability, because the dirt is automatically conveyed to the suction nozzle of the pump
3. High filtration efficiency
4. Compact design is achieved because of low space requirement, in addition to the option of block-type design with integrated flange connections
5. Design allows for varied applications due to construction in stainless steel with replaceable insert made of ceramic

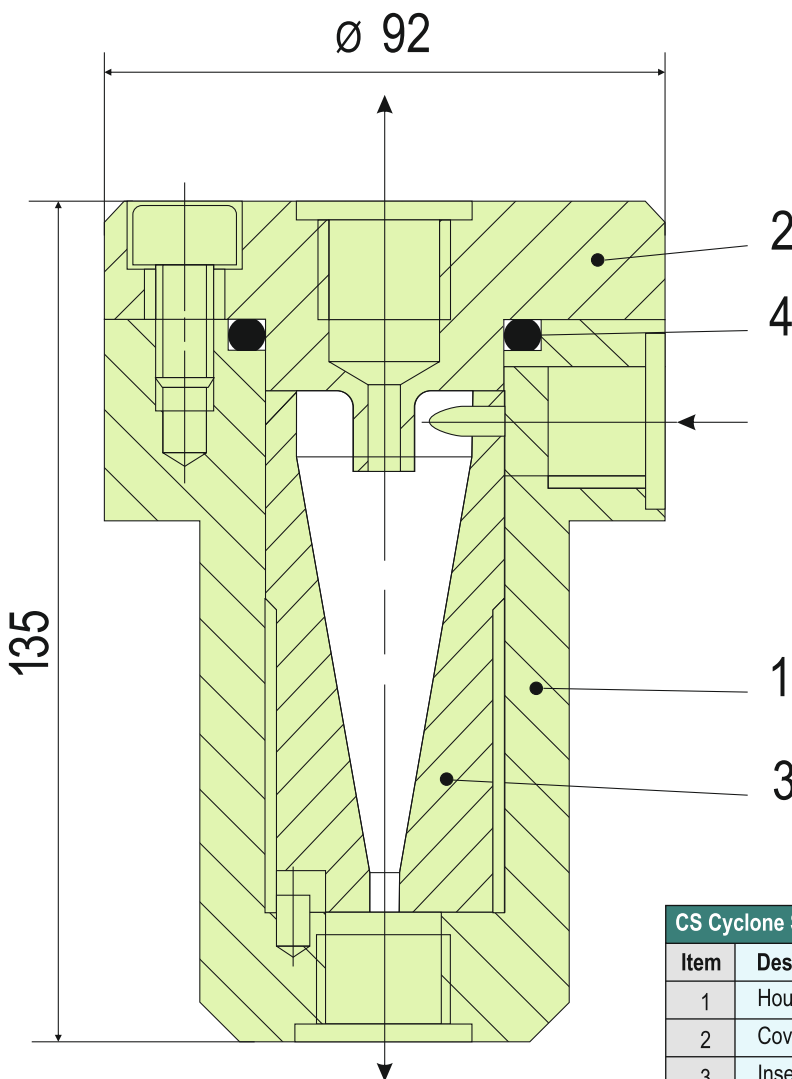

CS Cyclone Separator	
Item	Description
1	Housing
2	Cover
3	Insert
4	O-ring

**Typical Industrial Applications**

- Chemical industry
- Oil and gas industry
- Petrochemical industry
- Refining technology
- Water and waste water technology

**Functional Description**

Cyclone separators of the CS range are used to clean mainly aqueous liquids containing dirt and solids (e.g. in circulation systems of sewage, sludge or pipeline pumps). The best possible filtration efficiency is achieved when the specific weight of the solids is much higher than that of the carrier liquid, and when the differential pressure is as large as possible within the permissible pressure range (min. 1.7 bar in accordance with API 682). The viscosity of the medium is also a factor that needs to be taken into account.

**Operating and Installation Schematic**

The cyclone separator must always be installed in the vertical position. The pressure at the outlets (C) and (B) must be lower than at the inlet (A). Cleaned liquid is conveyed to the top (B) and the separated dirt to the suction port of the pump.

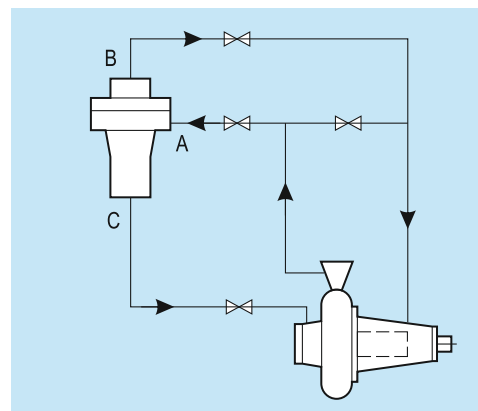

**Technical Features**

Designation	Insert	Allowable pressure <sup>1)</sup>	Allowable temperature <sup>1)</sup>	Connections	Connecting size	Housing/cover	O-ring
CS	Ceramic	64 bar (928 PSI)	125 °C (257 °F)	G, R, NPT, Flange	1/2"	1.4571	FKM

<sup>1)</sup> Higher values on request  
<sup>2)</sup> Other materials on request

The specifications, drawings, images etc included in this catalogue are intended to be generic and must be interpreted as equivalent or functionally equivalent, more specifically the performance capabilities mentioned in this catalogue is based on optimum values, however the performance of the product is dependent on size, material of construction, media, pressure, temperature, sliding velocity etc and it shall vary from size to size or application to application. Customers are requested to consult with Sealmatic before employing the product from this catalogue for any application.



### Product Description

The hand refill pump consists of a storage vessel with level indicator, filling filter and a hand pump with integrated check valve. It is mounted directly on the thermosiphon vessel or the pressure booster.

### Technical Features

1. For efficient processes, with a choice of 2 basic types
2. For manual refilling of buffer fluid units during operation
3. Designed for varied applications due to construction in stainless steel with borosilicate sight-glasses suitable for highly corrosive media
4. Reliability in operation due to the design of combined filling and ventilation filter in the hand refill pump
5. Two sight-glasses for reading the MIN/MAX fluid level

### Recommended applications

Chemical industry      Refining technology  
 Petrochemical industry      Pulp and paper industry  
 Oil and gas industry      Food and beverage industry

### Functional description

The hand refill pump is designed for manual refilling during operation in case of buffer fluid losses.

### Product Variants

Designation	Volume (litres)	Allowable temperature	Material, sight-glass/seal		Material, filling filter		Pressure control valve			
			Acrylic glass, Perbunan®	Borosilicate, T2	Polyamide	Stainless steel	None	16 bar (232 PSI)	30 bar (435 PSI)	63 bar (913 PSI)
HRP	2	60 °C (140 °F)	x		x				x	

Higher values on request  
 Other materials on request

# QFS2000

# Quench Fluid Reservoir – Seal Supply Systems



### Product Description

Circulation in accordance with API 682 / ISO 21049: Plan 51, Plan 52  
 Quench fluid supply system is employed for applications in sealing systems with a wide variety of operating parameters for supplying quench fluid to double and tandem mechanical seals. They act as a convenient fluid reservoir. The exchange of fluid takes place by the thermosiphon principle or by forced circulation, for example with a pumping screw. The QFS2000 stainless steel tank is equipped with sight-glasses for monitoring the MIN/MAX level and can be fastened with a lug fixture. The leakage overflow can be selectively discharged.

### Technical Features

1. Designed for varied applications due to construction in stainless steel with borosilicate sight-glasses suitable for highly corrosive media
2. Reliability in operation due to the design of combined filling and ventilation filter in the hand refill pump
3. Construction design for operating pressure up to 200 °C
4. Discharge of leakage is achieved due to integrated overflow design
5. To monitor the fluid volume a level switch can be installed instead of sight glass

### Recommended applications

Chemical industry      Refining technology  
 Petrochemical industry      Pulp and paper industry  
 Oil and gas industry      Food and beverage industry

### Notes

Install the quench fluid tank approx. 1 ... 2 m (3.3 ... 6.6 ft) above the mechanical seal. Install connection pipes to the mechanical seal with low flow resistance. Pipes must vent automatically in the direction of the tank. It is imperative that air pockets are prevented. The minimum filling level must always be above the connection socket at the side (in the case of the thermosiphon principle).  
 Quench fluid systems can be operated in two different modes:

#### Dead-end quench (Plan 51):

Quench fluid from an elevated tank. The characteristic feature of this principle is that no heat is dissipated by the system.

#### Circulation (Plan 52):

Quench fluid from an elevated tank; external tank, pressureless; thermosiphon or forced circulation. In this case heat is dissipated by the circulation. Cooling capacity by convection is minimal, however.

### Functional description

- Quench fluid systems are employed:
- to absorb leakage
  - to monitor the leakage rate (e.g. through periodic reading of the level in the tank)
  - to lubricate and to cool the outboard mechanical seal in a tandem arrangement
  - to prevent icing
  - to protect against dry running
  - to stabilize the lubricating film
  - to exclude air from the media in order to prevent a reaction with oxygen in the air

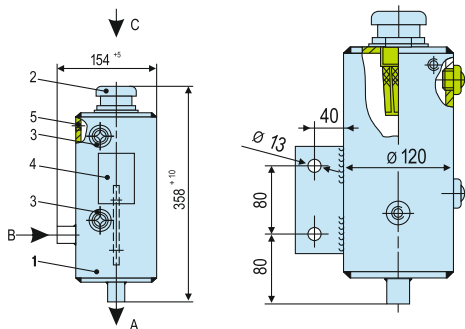

Item	Description
1	Storage tank (capacity 3L)
2	Inlet filter with vented cap
3	Sight-glass or level switch
4	Name plate
5	Overflow G 1/8

### Connections

A	To the mechanical seal
B	From the mechanical seal
C	Filling

Higher values on request  
 Other materials on request

The specifications, drawings, images etc included in this catalogue are intended to be generic and must be interpreted as equivalent or functionally equivalent, more specifically the performance capabilities mentioned in this catalogue is based on optimum values, however the performance of the product is dependent on size, material of construction, media, pressure, temperature, sliding velocity etc and it shall vary from size to size or application to application. Customers are requested to consult with Sealmatic before employing the product from this catalogue for any application.

Category			Category 1								
Configuration			1CW-FX	2CW-CW	2NC-CS	3CW-FB	3NC-BB				
Mechanical Seal	Seal Type A	Rotating	CTXAPI-SN	CTXAPI-DN	GSPH-Ta	CTXAPI-DN	GSPH-KD				
		Stationary									
Category		Category 2 and 3									
Configuration		1CW-FL	2CW-CW	2CW-CS	2NC-CS	3CW-FB	3CW-BB	3CW-FF	3NC-FB	3NC-BB	3NC-FF
Mechanical Seal	Seal Type A	Rotating	B750VN	B750VK	B750VK-GSPH	GSPH-Ta	B750VK	B750VK-D		GSPH-KD	
		Stationary	SB	SB-Ta			SB-Ta		SB-D	BGSR-Ta	GSR-D
	Seal Type B	Rotating	UFL850	UFL850-Ta			UFL850-Ta	UFL850-D			
		Stationary	UFLWT800	UFLWT800-Ta			UFLWT800-Ta	UFLWT800-D			
Seal Type C	Rotating	UFL650	UFL650-Ta			UFL650-Ta		UFL650-D			
	Stationary										

### API 682 4<sup>th</sup> Edition Code

Mechanical Seal			Design Options			Size	Plans
Category	Arrangement	Type	Containment Device	Secondary Seal Material	Face Material	Shaft Size	Piping Plan
2	2	A	P: Plain gland	I: FFKM (Inner position) F: FKM (Outer position)	N: Carbon vs Reaction Bonded Silicon Carbide	050	02/52

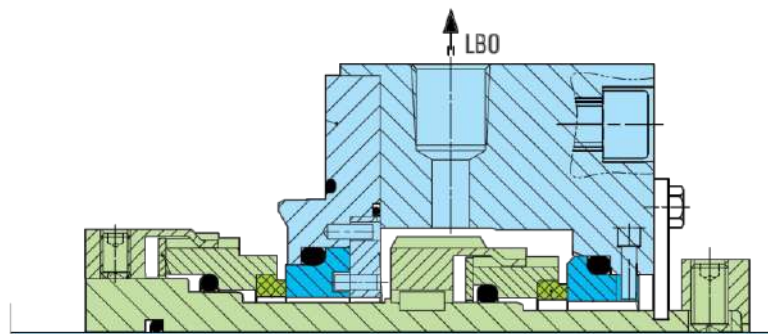

Seal designation: 22A-PI/FN-050-02/52

# Technical Information

## TTV O-rings

Double PTFE-encapsulated O-rings of the type used in SEALMATIC mechanical seals combine the elasticity of the core materials (synthetic rubber) with the chemical and thermal resistance of the PTFE. The material PTFE features good chemical and

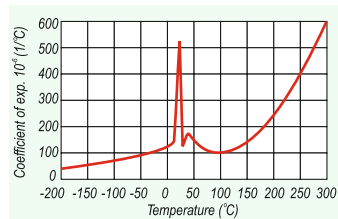

thermal resistance, but it also displays a high degree of rigidity, a low coefficient of thermal conductivity, an unfavourable expansion characteristic (see graph) and a tendency to cold flow.

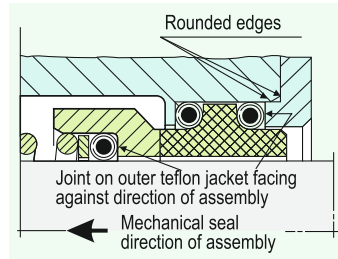

It is advisable, therefore, to avoid the use of O-rings made of solid PTFE.

The assembly position of double PTFE-encapsulated elastomers is critical. Care must be taken to ensure that the joint on the outer jacket faces against the assembly direction, as otherwise there is a risk of the jacket opening and being pulled off.

Bending of the jacket must be avoided at all costs to prevent leaks. Slip TTV O-rings onto tubes for safe storage.



## Screw locking

If no special provision is made for locking screw thread, use set screw with a suitable adhesive (e.g. Loctite®) after removing any grease.

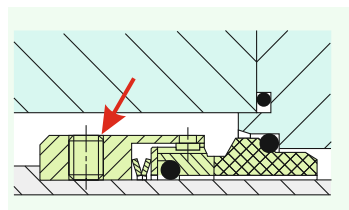

## Conical springs

When a conical spring is used for driving the seal (e.g. in standard types U200 and U300), the mechanical seal becomes **dependent on the direction of rotation**. Looking toward the sliding face of the rotating parts of the seal, shafts rotating in clockwise direction require right-hand springs and shafts rotating in anti-clockwise direction require left-hand springs. Mounting the conical spring is easier if you twist it onto the shaft with a screwing action in the same direction as the spring coiling. This screwing action will cause the spring to open. For brief reversals of the direction of rotation we recommend seal type "S30".

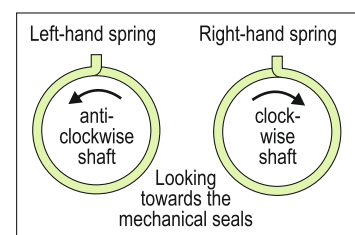
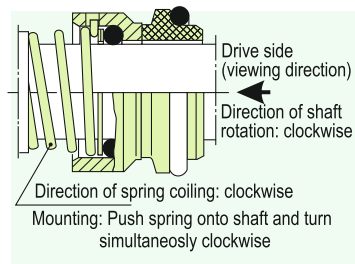

## Pressure vessel regulations

Requirements imposed by various international standards for Pressure Vessel Code on Group III pressure vessels (Section 8)

- International Pressure Vessel Code orders that pressure vessels be built and operated in accordance with the generally valid rules of engineering (such as the German AD Code, ASME etc).
- AD Bulletin W2 requires every pressure-bearing part made of austenitic steel to be accompanied by a material certificate EN 10204 3.1 B or 3.1C.

- The manufacturer must subject every pressure vessel to a pressure test.
- Every pressure vessels must be issued with a certificate confirming its correct production and pressure testing in accordance with the Pressure Vessel Code. This certificate is included with the delivery.

## Types of drive

For a seal to function properly, the shaft torque must be transmitted uniformly to the shaft sleeve and/or rotating parts under all operating conditions. Depending on the seal design it is necessary to make allowance for centrifugal and axial forces and in some case to observe special installation instructions. Incorrect fitting can cause, for example, jamming and de-formation of the seal.

### Typical arrangements

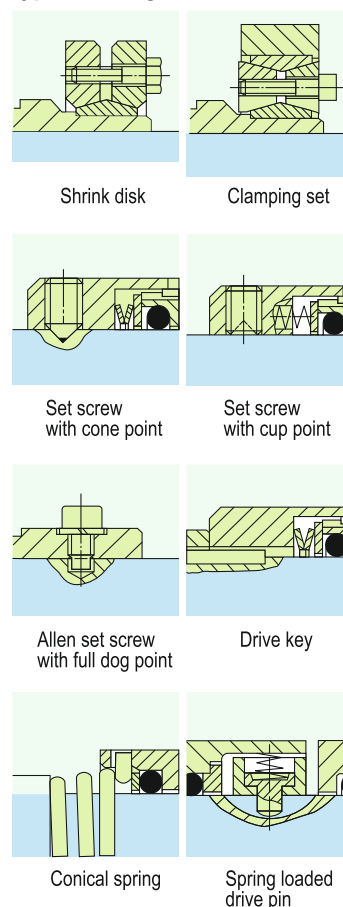

## Shrink disk

The pressure necessary for the transmission of torque is generated through clamping force on lubricated conical surfaces. The shrink disk couplings can be released at any time by slackening the tensioning screws. All the parts involved are subjected to elastic deformation only, so the original clearance is restored once the screws are released. Provided the conical surfaces are undamaged, the shrink disks can be retensioned any number of times (ensure correct lubrication). Shaft sleeves should not have a clearance diameter under the shrink disk and should make full contact with the shaft.

## Viscosity $\nu$

### Conversion table\*

The following conversion table shows the kinematic viscosity  $\nu$  in terms of conventional units of measurement at the same temperature.

$\nu$ mm <sup>2</sup> /s	°E	RI sec	SU sec
1.0	1.00	-	-
1.5	1.06	-	-
2.0	1.12	30.4	32.6
2.5	1.17	31.5	34.4
3.0	1.22	32.7	36.0
3.5	1.26	34.0	37.6
4.0	1.31	35.3	39.1
4.5	1.35	36.6	40.8
5.0	1.39	38.0	42.4
5.5	1.44	39.3	44.0
6.0	1.48	40.6	45.6
6.5	1.52	42.0	47.2
7.0	1.57	43.3	48.8
7.5	1.61	44.7	50.4
8.0	1.65	46.1	52.1
8.5	1.70	47.5	53.8
9.0	1.74	49.0	55.5
9.5	1.79	50.4	57.2
10.0	1.83	51.9	58.9
11.0	1.93	54.9	62.4
11.5	1.98	56.4	64.2
12.0	2.02	58.0	66.0
12.5	2.07	59.6	67.9
13.0	2.12	61.2	69.8
13.5	2.17	62.9	71.7
14.0	2.22	64.5	73.6
14.5	2.27	66.2	75.7
15.0	2.33	67.8	77.4
15.5	2.38	69.5	79.3
16.0	2.43	71.2	81.3
16.5	2.49	72.9	83.3
17.0	2.54	74.6	85.3
17.5	2.59	76.3	87.4
18.0	2.65	78.1	89.4
18.5	2.71	79.8	91.5
19.0	2.76	81.6	93.6
19.5	2.82	83.4	95.7
20.0	2.88	85.2	97.8
25.0	3.47	103.9	119.3
30.0	4.08	123.5	141.3
35.0	4.71	143.4	163.7
40.0	5.35	163.5	186.3
50.0	6.65	203.9	232.1
60.0	7.95	244.3	278.3
70.0	9.26	284.7	324.4
80.0	10.58	325.1	370.8
90.0	11.89	365.6	417.1
100.0	13.20	406.0	463.5
150.0	19.80	609.0	695.2
200.0	26.40	812.0	926.9
250.0	33.00	1015.0	1158.7
300.0	39.60	1218.0	1390.4
350.0	46.20	1421.0	1622.1
400.0	52.80	1624.0	1853.9
500.0	66.00	2030.0	2317.4
600.0	79.20	2436.0	2781.0
700.0	92.40	2842.0	3244.5
800.0	105.60	3248.0	3708.0
900.0	118.80	3654.0	4171.5
1000.0	132.00	4060.0	4635.0

Conventional units of measurement:

°E = degrees Engler

RI = Redwood Seconds I and II

SU = Saybolt Universal seconds

\* according to Ubbelohde mm<sup>2</sup>/s  $\cong$  cSt

# Technical Information

## Circulation

For single seals it is generally advisable to install a circulation pipe from the discharge nozzle of the pump to the seal chamber. A pipe size G1/4 is normally sufficient. There should be a close fitting neck bush between the pump casing and the seal chamber.

## Flushing

Flushing systems are installed in accordance with DIN ISO 5199, Appendix E, Plan No. 08a or API 610, Appendix D, Plan 32. A clean and mostly cold external medium is injected into the stuffing box in the area of the sliding faces via an orifice (throttle) into the medium to be sealed. Flushing is used either to lower the temperature or to prevent deposits forming in the area of the mechanical seal. Again it is recommended that a close fitting neck bush is employed.

## Quench

Quench is the term commonly used in sealing engineering for an arrangement that applies a pressureless external medium (fluid, vapour, gas) to a mechanical seal's faces on the atmosphere side. A quench is used on the one hand when a single mechanical seal does not function at all or only within certain limits without auxiliary measures or when a double mechanical seal with pressurized buffer medium is unnecessary. When an integral stationary seat stop is fitted, the quench pressure should not exceed 1 bar. A quench performs at least one of the duties described below.

### Fluid quench

- Absorption or removal of leakage by the quench medium Monitoring of the mechanical seal's leakage rate by periodic measurement of the level of the quench medium in the circulation vessel or thermosiphon vessel Lubrication and cooling of the standby mechanical seal
- Exclusion of air: For media which react with atmospheric oxygen the quenching medium stops the leakage making contact with the atmosphere
- Protection against dry running: For applications subject to brief, periods of vacuum and operation of pumps without pumping liquid (submersible pumps) the quenching medium prevents dry running of the mechanical seal
- Stabilization of the lubrication film: For operation under vacuum and/or sealing pressures close to the vapour pressure, the quenching medium stabilizes the lubrication film
- Cooling or heating of the outboard side of the mechanical seal.

### Steam quench

- Heating: For media with a high melting point the vapour quench prevents the leakage from solidifying in that area of the mechanical seal critical for its proper functioning
- Exclusion of air
- Removal of leakage

### Gas quench

- Icing protection: With operating temperatures  $< 0^{\circ}\text{C}$  (cryogenic mechanical seals), the injection of nitrogen or dry air into the seal housing prevents the mechanical seal parts on the atmosphere side from icing up
- Exclusion of air
- Removal of leakage

### Sealing the quench medium

- Outboard mini-gland – the preferred choice for steam, not so much for liquids
- Lip seals – the preferred choice for oils and water
- Mechanical seals – the preferred choice for all circulating quench fluids

In some cases, for mechanical seals to function correctly the conditions in which they operate must be altered. This depends on the seal type, the duty conditions including environmental protection, and the type of equipment into which the seals are fitted.

A simple change to a single seal's operating conditions in a dead-end arrangement can be made, for instance, by adding a recirculation line from the pump discharge to the seal chamber (API Plan 1).

As operational demands increase, so too must the capabilities of the supply units to support the mechanical seal.

The following section contains the necessary information for the correct selection of supply systems and auxiliary equipment to ensure reliable operation of your mechanical seals.

## Barrier medium

The barrier medium fulfills two functions - it dissipates the heat generated by the seal and it prevents the product from penetrating the sealing gap to any appreciable degree. Any liquid and any gas can be chosen as barrier medium, with due consideration to the corrosion resistance of the parts it comes into contact with and to its compatibility with the process medium and surroundings. The barrier medium must not contain any solids. It is particularly important that liquid barrier media do not tend to precipitate and that they have a high boiling point, a high specific thermal capacity and good thermal conductivity. Clean, demineralised water satisfies these requirements to a high degree. Hydraulic oil is often used in buffer fluid units and water in closed barrier fluid circuits. To prevent damage to the TS and sealing system, due allowance must be made for the co-efficient of volumetric expansion of the barrier fluids used.

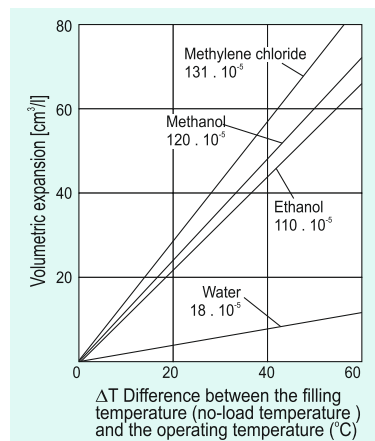

Volumetric expansion of various buffer media

## Barrier systems

To guarantee the correct working of double mechanical seals, the barrier interspace (between the product side and the atmosphere side of the mechanical seal) must be completely filled with clean barrier medium.

Before starting up double mechanical seals it is vital, therefore, to ensure a sufficient rate of circulation of the barrier fluid. The barrier fluid pressure should lie 10 % or at least 2...3 bar above the maximum pressure to be sealed. The flow rate must be controlled to ensure that the temperature of the barrier medium at the outlet lies below approximately  $60^{\circ}\text{C}$  and that it does not exceed boiling point under any circumstances. The maximum acceptable inlet/outlet temperature differential is 15 K. The barrier fluid outlet lies at the highest point of the stuffing box for automatic venting of any vapour. In view of the basic conditions of operation, a barrier system must perform the following functions:

- Build-up pressure in the barrier interspace
- Compensation of leakage
- Circulation of the barrier medium
- Cooling of the barrier medium
- Cooling of the seal

Barrier fluid systems for liquid-lubricated mechanical seals break down into two basic categories:

### Open circuit

A circuit in which both the circulation and the pressurization take place through a single barrier fluid system.

After each circuit the barrier fluid is relieved and collected in a pressureless tank.

### Closed circuit

In this type of circuit all the components are kept under the same pressure. Pressure is applied by means of nitrogen or the process medium pressure or via a refill system. Pressure loss in the circuit must be taken into account when drawing up the design.

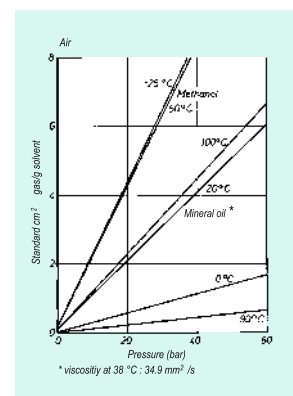
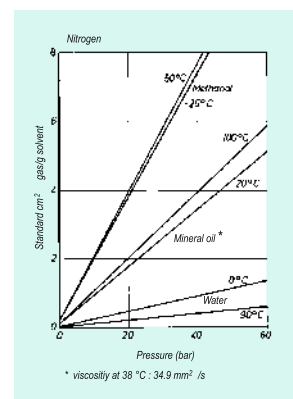



# Technical Information

## Circulation systems to API 682 / ISO 21049

### Clean pumping media

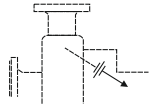

**Plan 01**  
Internal circulation from the pump case to the seal.

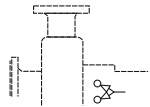

**Plan 02**  
Dead end seal chamber with no circulation. Stuffing box cooling and a neck bush are necessary, unless otherwise specified.

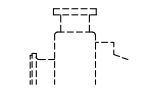

**Plan 03**  
Circulation between the seal chamber and the pump created by the design of the seal chamber. (eg. taper bore)

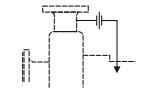

**Plan 11**  
Circulation from the pump discharge, through an orifice to the seal.

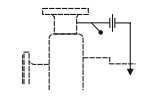

**Plan 12**  
Circulation from the pump discharge, through a strainer and an orifice to the seal.

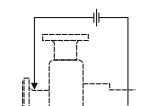

**Plan 13**  
Circulation from the seal chamber, through an orifice and back to pump suction.

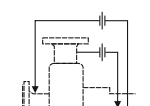

**Plan 14**  
Circulation from pump discharge through orifice to seal chamber and through orifice back to pump suction. (Combination of Plan 11+13).

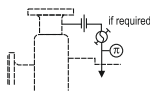

**Plan 21**  
Circulation from the pump discharge, through an orifice and a cooler to the seal.

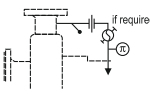

**Plan 22**  
Circulation from the pump discharge, through a strainer, an orifice and a cooler to the seal.

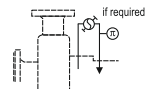

**Plan 23**  
Circulation by means of a pumping ring from the seal, through a cooler and back to the seal.

### Contaminated and special pumping media

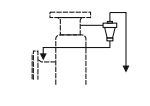

**Plan 31**  
Circulation from the pump discharge through a cyclone separator.

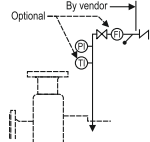

**Plan 32**  
Injection of clean fluid into the seal chamber from an external source

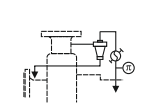

**Plan 41**  
Circulation from the pump case through a cyclone separator, and clean fluid through a cooler to the seal.

### Buffer/barrier medium between seals

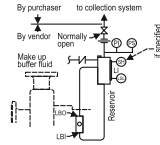

**Plan 52**  
External fluid reservoir, pressurless, thermosiphon or forced circulation as required.

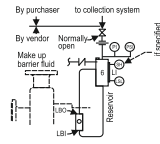

**Plan 53A**  
Circulation with thermosiphon system, pressurized. Forced circulation by pumping ring or circulation pump.

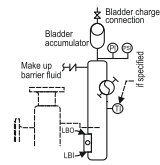

**Plan 53B**  
Circulation with bladder accumulator and cooler, pressurized. Forced circulation by pumping ring or circulation pump.

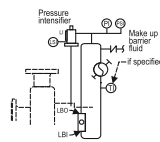

**Plan 53C**  
Circulation with pressure booster and cooler. Pressurized by reference pressure of seal chamber. Forced circulation by pumping ring or circulation pump.

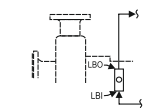

**Plan 54**  
Circulation of clean fluid from an external system.

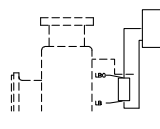

**Plan 55**  
External source to provide a clean unpressurized buffer fluid to a dual unpressurized seal.

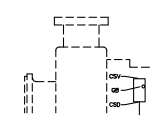

**Plan 71**  
Tapped connections for purchaser's use. Typically this plan is used when the purchaser may use buffer gas in the future.

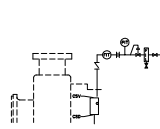

**Plan 72**  
Externally supplied buffer gas for arrangement 2 seals. Buffer gas may be used alone to dilute seal leakage or in conjunction with Plan 75 or 76 to help sweep leakage into a closed collection system. Pressure of buffer gas is lower than process side pressure of inner seal.

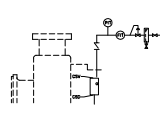

**Plan 74**  
Externally supplied barrier gas for arrangement 3 seals. Barrier gas is maintained at a pressure greater than a seal chamber pressure.

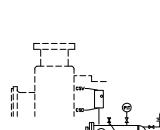

**Plan 75**  
Containment seal chamber leakage collection system for condensing or mixed phase leakage on arrangement 2 seals. This plan is used when pumped fluid condenses at ambient temperature.

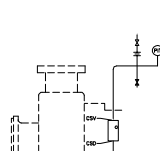

**Plan 76**  
Containment seal chamber drain for non-condensing leakage on arrangement 2 seals. This plan is used if the pumped fluid does not condense at ambient temperature.

### Plan for atmospheric side

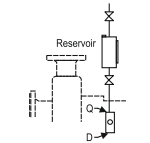

**Plan 51**  
Dead-end quench (usually methanol)

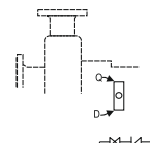

**Plan 61**  
Tapped connections for the customer's use.

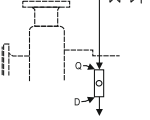

**Plan 62**  
External fluid quench (steam, gas, water, etc.)

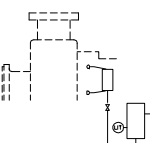

**Plan 65A**  
Atmospheric leakage collection and detection for condensing leakage with failure detection by excess flow into system.

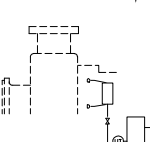

**Plan 65B**  
Atmospheric leakage collection and detection for condensing leakage with failure detection by cumulative leakage into system.

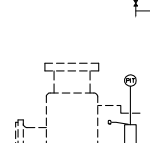

**Plan 66A**  
External leakage detection arrangement with throttle bushings.

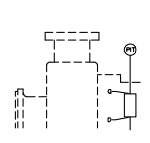

**Plan 66B**  
External leakage detection arrangement with orifice plug.

### Legend

	Cooler
	Cyclone separator
	Strainer
	Flow control valve
	Block valve
	Non return valve
	Orifice
D	Drain
F	Flush
FI	Flow indicator
LBI	Liquid buffer/barrier inlet
LBO	Liquid buffer/barrier outlet
LI	Level indicator
LSH	Level switch MAX
LSL	Level switch MIN
PI	Pressure indicator
PS	Pressure switch
PSL	Pressure switch MIN
TI	Temperature indicator
Q	Quench

# Technical Information

## Symbols

<b>A</b>	Area of sliding face
<b>A<sub>H</sub></b>	Area hydraulically loaded by medium pressure
<b>b</b>	Width of sliding face
<b>c</b>	Specific heat capacity
<b>D</b>	Outer diameter of sliding face
<b>d</b>	Inner diameter of sliding face
<b>D<sub>a</sub></b>	Outer diameter of bellows
<b>d<sub>H</sub></b>	Hydraulic diameter
<b>D<sub>i</sub></b>	Inner diameter of bellows
<b>d<sub>m</sub></b>	Mean diameter of sliding face
<b>d<sub>w</sub></b>	Diameter of shaft
<b>f</b>	Coefficient of friction
<b>F<sub>f</sub></b>	Spring force
<b>h</b>	Gap width
<b>H</b>	Delivery head of pumping screw
<b>k</b>	Balance ratio
<b>k<sub>1</sub></b>	Pressure gradient factor
<b>n</b>	Speed
<b>P<sub>1</sub></b>	Medium pressure
<b>P<sub>2</sub></b>	Atmosphere pressure
<b>P<sub>3</sub></b>	Buffer/Barrier fluid pressure
<b>ΔP</b>	P <sub>1</sub> -P <sub>2</sub> ; P <sub>3</sub> -P <sub>1</sub> ; P <sub>3</sub> -P <sub>2</sub>
<b>P<sub>f</sub></b>	Spring pressure
<b>P<sub>G</sub></b>	Sliding pressure
<b>P<sub>r</sub></b>	Calculated load for the frictional force of the secondary seal
<b>P<sub>R</sub></b>	Power consumption of sliding faces
<b>P<sub>V</sub></b>	Turbulence loss through rotating parts
<b>Ṁ</b>	Delivery rate
<b>Q</b>	Mechanical seal leakage rate
<b>R<sub>a</sub></b>	Mean roughness index (calculated)
<b>t, T</b>	Temperature of the medium to be sealed
<b>ΔT</b>	Rise in temperature of the medium to be sealed
<b>t<sub>3</sub></b>	Temperature of the buffer medium
<b>v<sub>g</sub></b>	Sliding velocity
<b>η</b>	Dynamic viscosity
<b>χ</b>	Load factor
<b>ρ</b>	Density
<b>ν</b>	Kinematic viscosity

## Mechanical seals according to EN 12756 (code system)

For single mechanical seals there is a distinction drawn between standard (N) and short (K) types. For double mechanical seals (back-to-back) EN specifies the short type only.

### Single seal

Designation	Description	Position				
		1	2	3	4	5
N = standard type with I <sub>1N</sub> K = short type with I <sub>1k</sub> C = type C						
U = no shaft step B = with shaft step C = 0						
Nominal diameters <b>d<sub>i</sub></b> and <b>d<sub>o</sub></b> of the mechanical seal Shaft/shaft sleeve diameters are always three-digit numbers beneath the stationary seat for types U and B						
<b>Direction of rotation of the Mechanical Seal</b>						
Type N and K (is also the spring winding direction)	Type C					
<b>R = clockwise</b>						
Looking from the stationary seat toward the seal face with the seal face rotating in clockwise direction	Looking from the drive side with the shaft rotating in clockwise direction					
<b>L = anti clockwise</b>						
Looking from the stationary seat toward the seal face with the seal face rotating in anticlockwise direction	Looking from the drive side with the shaft rotating in anticlockwise direction					
<b>S = independent of direction of rotation</b>						
Spring type (state single spring or multiple springs in your order)						
Pinned stationary seat 0 = no torsion lock, without anti-rotation pin 1 = with torsion lock, with anti-rotation pin 2 = for type C						
<b>Material</b> (see inside end cover)						

### Double seal

Designation	Description	Position							
		1	2	3	4	5	6	7	8
U = no shaft step B = with shaft step C = type C	on product side								
U = no shaft step B = with shaft step C = type C	on atmosphere side								
Nominal diameters <b>d<sub>1</sub></b> and <b>d<sub>10</sub></b> (always three-digit numbers)									
Direction of rotation (see single seal)									
Anti-rotation pin for stationary seat on the atmosphere and/or product side 0 = without anti-rotation pin 1 = with anti-rotation pin for stationary seat on atmosphere side 2 = with anti-rotation pin for stationary seat on product side 3 = with anti-rotation pin for stationary seal on the atmosphere and product sides 4 = for type C									
Positive retention for stationary seat on the product side 0 = without D = with E = for type C									
<b>Material</b> (see inside end cover)									

# Technical Information

## Seal and Material Code to API 682/ISO 21049

Seal designations compliant with ISO 21049 1st Issue and API 682 3rd Edition

The seal description was redefined in ISO 21048, Annex D. Contrary to the earlier arrangement, no details such as the face and O-ring materials used are included in the designation. Such details are now to be found only in the seal data sheet.

The following rule applies for seal codes with four or more digits.

### 1st digit Seal Category

Here a C is used followed by the corresponding category number 1, 2 or 3 to which the seal belongs.

### 2nd digit Arrangement

Here an A is used followed by the number 1, 2 or 3 according to the seal arrangement applied.

### 3rd digit Seal Type

Here the letter A, B or C is used according to the seal in question.

### 4th digit and other Supply System Plans

The cooling and/or flushing diagrams used are listed here one after the other without separating commas.

#### Example 1:

C1A1A11  
Seal category 1  
Seal arrangement 1 (single seal)  
Seal type A (O-ring seal)  
Product circulation according to Plan 11

#### Example 2:

C3A2B1152  
Seal category 3  
Seal arrangement 2 (double seal pressureless)  
Seal type B (rotating metal bellows seal)  
Product circulation according to Plan 11  
Pressureless quench according to Plan 52

## Seat locking<sup>1)</sup> to EN 12756

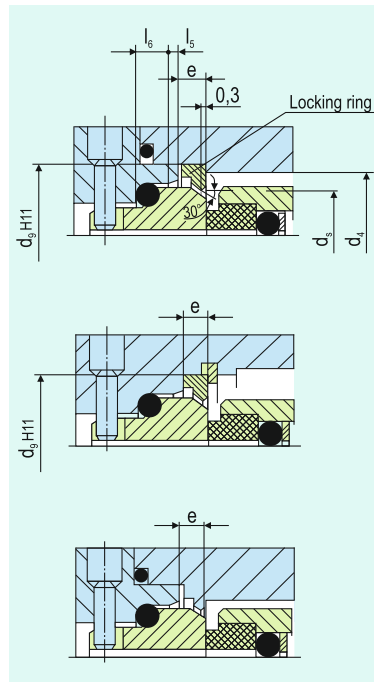

d <sub>1</sub>	d <sub>2</sub>	d <sub>4</sub>		d <sub>9</sub>		l <sub>5</sub>	l <sub>6</sub>	e	d <sub>s</sub>
		U	B	U	B				
10	14	22	26	26	30	1.5	4	4	-
12	16	24	28	28	32	1.5	4	4	-
14	18	26	34	30	38	1.5	4	4	-
16	20	23	36	32	40	1.5	4	4	-
18	22	34	38	38	42	2.0	5	4	31.2
20	24	36	40	40	43	2.0	5	4	33.2
22	26	38	42	42	46	2.0	5	4	35.2
24	28	40	44	43	48	2.0	5	4	37.2
25	30	41	46	46	50	2.0	5	4	38.2
28	33	44	49	48	53	2.0	5	4	41.2
30	35	47	61	50	60	2.0	5	4	43.2
32	38	48	58	53	62	2.0	5	4	46.2
33	38	49	58	53	62	2.0	5	4	46.2
35	40	51	60	60	65	2.0	5	4	48.2
38	43	58	63	62	67	2.0	6	6	53.5
40	45	60	65	66	70	2.0	6	6	55.5
43	48	63	68	67	72	2.0	6	6	58.5
45	50	65	70	70	75	2.0	6	6	60.5
48	53	68	73	72	77	2.0	6	6	63.5
50	55	70	75	75	86	2.5	6	6	67.5
53	58	73	83	77	86	2.5	6	6	70.6
55	60	75	85	86	91	2.5	6	6	72.6
58	63	83	88	88	93	2.5	6	6	75.6
60	65	85	90	91	96	2.5	6	6	77.6
63	68	88	93	93	98	2.5	6	6	80.6
65	70	90	95	97	103	2.5	6	6	82.6
68	-	93	-	98	-	-	-	6	88.6
70	75	95	104	103	018	2.5	7	6	90.2
75	80	104	109	108	150	2.5	7	6	95.2
80	85	109	114	120	125	3.0	7	6	103.0
85	90	114	119	125	130	3.0	7	6	108.0
90	95	119	124	130	136	3.0	7	6	113.0
95	100	124	129	135	140	3.0	7	6	117.5
100	105	129	134	140	145	3.0	7	6	122.5

<sup>1)</sup>not applicable for seats made of carbon.

## Balance ratio

The balance ratio is a non-dimensional factor of the mechanical seal and is defined as

$$k = \frac{\text{hydraul. loaded area } A_H}{\text{area of sliding face } A}$$

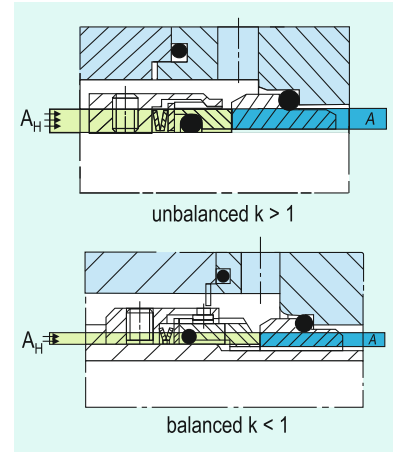

In practice k values are selected between 0.65 and 1.2. With a lower k value, the safety against thermal overload will increase, but the mechanical seal may also lift off more easily.

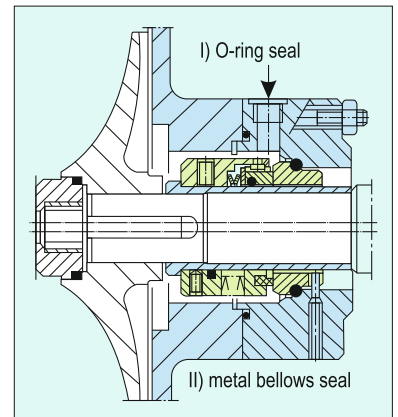

Unlike an O-ring seal, the hydraulic diameter of a bellows seal is not a fixed geometric value. It is conditional on the absolute level of the pressure to be sealed and on the direction of pressurization (internal or external pressure).

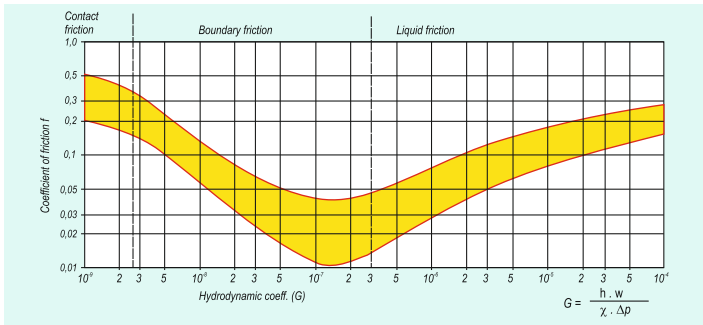

## Load factor $\chi$

The balance ratio is just a non-dimensional factor used to assess a mechanical seal. A second one is the load factor  $\chi$ .

$$\chi = k + \frac{p_f \pm p_r}{\Delta p}$$

The balance ratio and the load factor are practically identical when the pressure differentials to be sealed are large. The friction at the dynamic secondary seals  $p_r$  is usually disregarded in the calculation.

## Sliding pressure $p_g$

The term "sliding pressure" is understood to be the surface pressure on the two sealing faces which remains after subtracting all those forces that act on the seal face and which are balanced by hydraulic pressures. The sliding pressure is conditional on the pressure differential to be sealed, the balance ratio, the pressure conditions inside the sealing gap i.e. gap between the seal faces (pressure gradient factor) and the spring pressure. The pressure gradient factor  $k_1$  can assume values between 0 and 1, depending on the geometry of the two sealing faces. For sealing gap geometries which converge in leakage direction - V-gap for externally pressurized seals - the value of  $k_1$  is  $> 0.5$ , while for sealing gap geometries which diverge in leakage direction - A-gap for externally pressurized seals - the value of  $k_1 < 0.5$ . For simplified calculations the value of  $k_1$  is generally taken to be 0.5. Under unfavourable conditions the sliding pressure can become negative, causing the sealing faces to open resulting in excessive leakage.

$$p_g = \Delta p \cdot (k - k_1) + p_r$$

## Coefficient of friction $f$

The coefficient of friction  $f$  is conditional on the materials that are in contact, the medium being sealed, the sliding velocity and the design-related conditions of contact between the sliding faces.

For general considerations and calculations, a coefficient of friction of between 0.05 and 0.08 can be applied as a good approximation. As can be seen in the graph, a lower value is obtained under improved conditions of lubrication, e.g. due to partial build-up of hydrodynamic pressure in the sealing gap. On the other hand, when a mechanical seal is run under purely hydrodynamic conditions of operation, the coefficient of friction will rise as the speed increases - similar to hydrodynamic bearings.

## Gap width $h$

### Seals with contacting faces

In contact seals with a theoretically parallel sealing gap, the distance between the two sealing faces is conditional on the roughness of the surfaces.

Numerous measurements taken in the laboratory and in practice with due allowance for external factors indicate that a mean gap width of less than 1 mm can be used as a basis for calculating the normal degree of leakage.

### Seals with non-contacting faces

Hydrostatically or hydrodynamically balanced, non-contacting mechanical seals adjust automatically to a defined gap width during operation. The width of the gap depends mainly on the shape of the gap in radial as well as circumferential direction, on the operating conditions and on the medium.

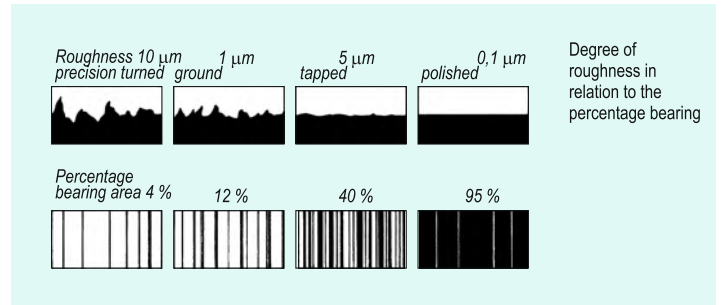

## Surface roughness

Microfinished sliding faces made of various materials display the following average, arithmetic mean roughness values ( $R_a$ ):

<b>Tungsten carbide, nickel-bonded</b>	: 0,01 $\mu\text{m}$
<b>Silicon carbide (SiC)</b>	: 0,04 $\mu\text{m}$
<b>Special cast Cr-steel</b>	: 0,15 $\mu\text{m}$
<b>Carbon graphite</b>	: 0,10 $\mu\text{m}$
<b>Aluminum oxide</b>	: 0,15 $\mu\text{m}$
<b>C-SiC-Si/C-SiC</b>	: 0,15 $\mu\text{m}$

The lower the roughness value, the higher the percentage bearing area and hence the higher load capacity of a mechanical seal.

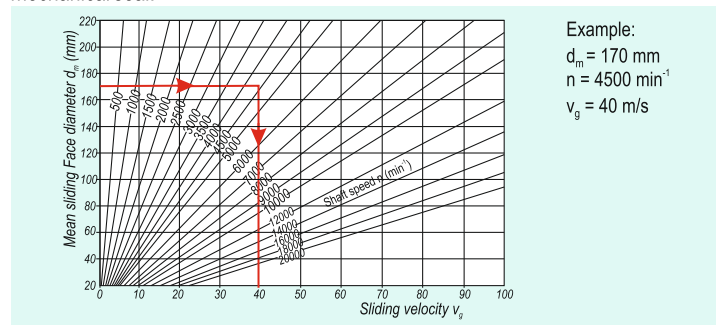

## Sliding velocity $v_g$

The sliding velocity is usually quoted in relation to the mean sliding face diameter.

## Cooling water requirements

When estimating the amount of cooling water required by heat exchangers it can be assumed that the temperature of the cooling water will increase by 5 K between the inlet and the outlet. This means that 1 l/min of cooling water dissipates 350 W.

## Turbulence losses $P_v$

The turbulence-related consumption of power is not significant until the circumferential speed reaches 30 m/s. It must be given due consideration particularly with special seals.

## Power consumption

The total power consumption of a mechanical seal is calculated from

- The power consumed by the sliding faces.
- The power consumption due to turbulence created by the rotating parts.

## Heat transfer

The total power consumption of a mechanical seal has to be dissipated into the medium or the buffer fluid by means of appropriate measures in order to stop the seal from overheating. The necessary fluid flow rate for removal of the power losses is calculated by

$$\dot{V} = \frac{P_R + P_V}{\Delta T \cdot c \cdot \rho}$$

Under certain conditions of installation or operation heat may pass from the product to the sealing compartment and will need to be taken into account when calculating the circulation rate.

### Example calculation:

$$P_R = 420 \text{ W (1 W = 1 J/s)}$$

$$\Delta T = 10 \text{ K}$$

Fluid: Water;

$$c = 4200 \text{ J (kg} \cdot \text{K)}$$

$$\rho = 1 \text{ kg/dm}^3$$

$$\dot{V} = \frac{420 \text{ W} \cdot \text{kg} \cdot \text{K} \cdot \text{dm}^3}{10 \text{ K} \cdot 4200 \text{ Ws} \cdot 1 \text{ kg}}$$

$$= 0.01 \text{ l/s} = 0.6 \text{ l/min}$$

# Technical Information

## Prior to installation

To fit a seal you will need its installation and operating instructions with the correct drawing. Before starting, check the dimensions, the maximum acceptable deviations and the geometrical tolerances of the machine.

### Edges and shoulders

All edges and shoulders onto or into which the mechanical seal is pushed during installation must be chamfered, deburred and rounded off to less than  $30^\circ \times 2\text{ mm}$ .

### Dimensional deviations

Acceptable deviations for dimensions having no tolerance specification: ISO 2768

- Part 1, fine/medium for linear and angular dimensions
- Part 2, tolerance class K for general geometrical tolerances

## Axial run-out

### Mounting face

Axial run-out depends on the speed. Permissible values are indicated by the graph.

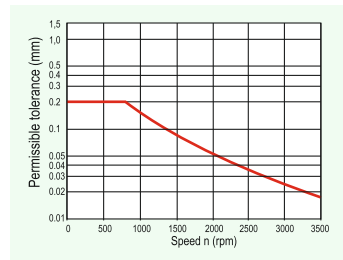
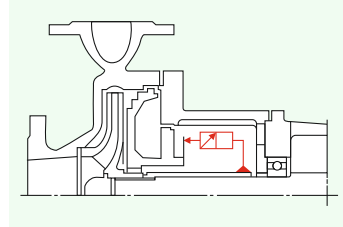

## Surface finish

### Finished surfaces according to EN12756

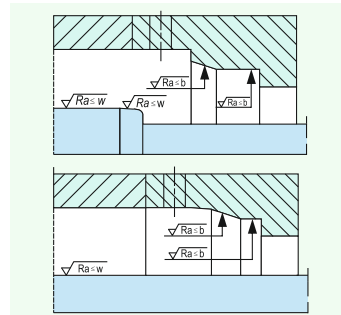

Mean roughness index	for secondary seal material $R_a$	
	b	w
Elastomers	$2.5\ \mu\text{m}$	$0.8\ \mu\text{m}$
Non-elastomers or optional use of elastomers and non-elastomers	$1.6\ \mu\text{m}$	$0.2\ \mu\text{m}$

## Extrusion characteristics of elastomeric O-rings

The extrusion resistance of elastomeric O-rings can be greatly enhanced by the use of support rings.

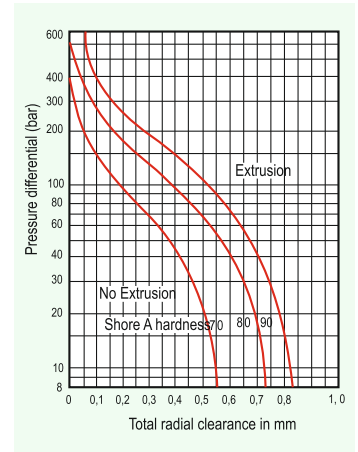

## Concentricity tolerance

### Shaft in accordance with ISO 5199

In the area of the mechanical seal the shaft concentricity tolerance must not exceed  $50\ \mu\text{m}$  for diameters  $< 50\ \text{mm}$ ,  $50\ \mu\text{m} - 80\ \mu\text{m}$  for diameters between  $50$  and  $100\ \text{mm}$ , and  $110\ \mu\text{m}$  for diameters  $> 100\ \text{mm}$ .

### Seal chamber bore

For sliding velocities of  $v_g < 25\ \text{m/s}$  the concentricity tolerance of the seal chamber in relation to the shaft should not exceed  $0.2\ \text{mm}$ , and when pumping screws are used it should not exceed  $0.1\ \text{mm}$  due to the effect of the pumping characteristic. If these values are exceeded please contact Sealmatic.

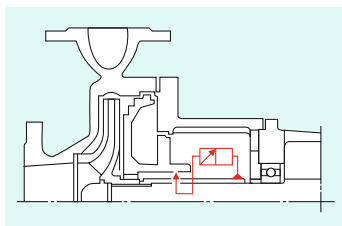
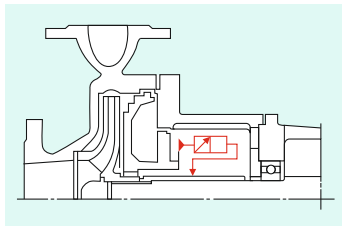

Absolute cleanliness and care are essential when fitting mechanical seals. Dirt and damage to sliding faces and O-rings jeopardize a seal's function. Any protective covering on the sliding faces must be removed without trace. Never put lubricant on the sliding faces - mount only in a completely dry, dust free and clean state. The accompanying installation instructions and the notes on the assembly drawings must be observed exactly.

### Fitting advice

To reduce the friction on O-rings when mounting seals on a shaft or when inserting seal cartridges in their housing, apply a thin coating of silicon grease or oil to the shaft or housing (N.B.: this does not apply to elastomer bellows seals). Never allow EP rubber O-rings to come into contact with mineral oil or grease. When inserting stationary seats, be careful to apply even pressure and use only water or alcohol to reduce O-ring friction.

## Mechanical Seal Installation

### Screw locking

If no special provision is made for locking screw threads, use set screws with a suitable adhesive (e.g. Loctite®) after removing any grease.

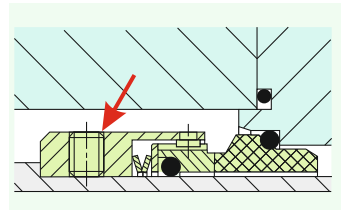

### Venting

To prevent damage to the sliding faces from dry running, the buffer space must be carefully vented **after you have installed the seal**. This is particularly important for those types of buffer/barrier fluid systems that do not vent themselves or are partially self venting (double seal with buffer/barrier fluid systems).

# Stationary Seats General Table

Seats				Types of Seats																					
Type	Seal Type	Version	Description/ materials	UG100	UG120	UG130	UG943	U300	U320	U370	U370G	U370GN	U320N	U700(F)	U740(F)	U740(F)-D	B120N	B170GN	B700(F)	B740(F)	B740(F)-D	BJ920	BJ970G	UFL800N	TB850
G4	U320		solid Special Cast Chrome Steel, Ceramic, Silicon Carbide/Tungsten Carbide	●	●	●	●		●	●	●	○	○	●	●	○	○	○	○	○	○	○	○	○	●
G6	U320N4		solid Special Cast Chrome Steel, Ceramic, Silicon Carbide/Tungsten Carbide	●	●	●	●		○	○	○	●	●	●	●	○	○	○	○	○	○	○	○	○	●
G7	U320S8		solid Special Cast Chrome Steel, Ceramic, Silicon Carbide/Tungsten Carbide	●	●	●	●		●	●	●	○	○	○	○	○									
G9 to DIN 24960	U320N		solid Special Cast Chrome Steel, Ceramic, Silicon Carbide/Tungsten Carbide	●	●	●	●		○	○	○	●	●	●	●	●	●	●	●	●	●	○	○	●	
	U700N		Carbon Resin/Antimony Impregnated	○	○	○		●		●	○	●		●	●	●									
	B700N		Carbon Resin/Antimony Impregnated														●	●	●	●	●				
	U377GN		Shrunk in Tungsten Carbide/ Silicon Carbide	●	●	●	●		○	○	○	●	●	●	●	●									
	U177GN		Shrunk in Tungsten Carbide/ Silicon Carbide														●	●	●	●	●				
G12	U377G		Shrunk in Tungsten Carbide/ Silicon Carbide	●	●	●	●		●	○	●	○	○	●	●	●									
G13	U300		solid Carbon Resin/Antimony Impregnated	●	●	●		●		●	●	○		●	●	●									
G15	B721G15 B740G15		Shrunk in Tungsten Carbide/ Silicon Carbide (cooled)														○	○	○	●	○				
G16	BJ920N		solid Special Cast Chrome Steel, Ceramic, Silicon Carbide/Tungsten Carbide	○	○	○	○		○	○	○	○	○	○	○	○	○	○	○	○	○	○	○	●	
G18	U377GS8		Shrunk in Tungsten Carbide/ Silicon Carbide	●	●	●	●		●	○	●	○	○	●	●	●									
G30	U300N4		solid Carbon Resin/Antimony Impregnated	○	○	○		●		●	○	●		●	●	●									
G35	TB850		double-elastic mounted, solid Ceramic, Tungsten Carbide/ Silicon Carbide																					○	
G42	TB850		Ceramic, Tungsten Carbide/ Silicon Carbide																					●	
G50	UG943		solid Special Cast Chrome Steel, Ceramic, Silicon Carbide/Tungsten Carbide	○	○	○	●																		
G55	UG943		solid Special Cast Chrome Steel, Ceramic, Silicon Carbide/Tungsten Carbide	○	○	○	●																		
G60	UG100		solid Special Cast Chrome Steel, Ceramic, Silicon Carbide/Tungsten Carbide	●	●	●	○																		
G115	B750G115		solid Silicon Carbide/Tungsten Carbide (Cooled)														○	○	○	●	○				

- – Default
- – Optional

# Table of Materials

## Face Materials (Item 1/2)

### Synthetic Carbons

A	Carbon graphite antimony impregnated
B	Carbon graphite resin impregnated, approved for foodstuffs
B3	Carbon graphite resin impregnated
B4	Electrographite resin impregnated
B5	Carbon, resin bonded
C	Electrographite antimony impregnated

### Metals

E	Cr-Steel
G	CrNiMo-Steel
S	Special cast CrMo-Steel

### Carbides

#### U = Tungsten carbides

U1	Tungsten carbide, Co-binder
U2	Tungsten carbide, Ni-binder
U22	Tungsten carbide, Ni-binder (shrunk-in)
U3	Tungsten carbide, NiCrMo-binder
U37	Tungsten carbide, NiCrMo-binder (shrunk-in)
U7	Tungsten carbide, binder-free

#### Q = Silicon carbides

Q1	SiC, silicon carbide, sintered pressureless
Q12	SiC, silicon carbide, sintered pressureless (shrunk-in)
Q2	SiC-Si, reaction bonded
Q22	SiC-Si, reaction bonded (shrunk-in)
Q3	SiC-C-Si, carbon silicon impr.
Q32	SiC-C-Si, carbon silicon impr.
Q6	SiC-C, SiC, sintered pressureless with carbon
Q4	C-SiC, carbon surface silicated
Q19	SiC, DLC- coated
Q15	SiC, Diamond face

#### Standards followed:

EN 12756  
ISO 1629

## Metal Oxides (Ceramics)

V	Al-Oxide > 99%
V2	Al-Oxide > 96%
X	Steatite (Magnesia silicate)

### Plastics

Y1	PTFE, glassfiber reinforced
Y2	PTFE, Carbon reinforced

## Secondary Seal Components (Item 3)

### Elastomers, not wrapped

B	Butyl rubber
E	Ethylene propylene rubber
K	Perfluorocarbon rubber
N	Chloroprene rubber
P	Nitrile-butadiene-rubber
S	Silicone rubber
V	Fluorocarbon rubber
X	Aflas
X4	HNBR

### Elastomers, wrapped

M1	FKM, double PTFE wrapped
M2	EPDM, double PTFE wrapped
M3	VMQ, double PTFE wrapped
M4	CR, double PTFE wrapped
M5	FKM, FEP wrapped
M7	FKM, double PTFE wrapped/PTFE solid

### Differing Materials

U1	Perfluorocarbon rubber/PTFE
----	-----------------------------

## Non-Elastomers

G	Pure graphite
T	PTFE (Polytetrafluoroethylene)
T2	PTFE glass fiber reinforced
T3	PTFE carbon reinforced
T12	PTFE carbon-graphite reinforced

## Spring and Construction Mat. (Item 4/5)

### Spring Materials

G	1.4571	CrNiMo Steel
M	2.4610	Hastelloy® C-4 Nickel-base alloy
M5	2.4819	Hastelloy® C-276

### Construction Materials

D	St	C steel
E	1.4122	Cr steel
F	1.4301	CrNi steel
F	1.4308	CrNi cast steel
F1	1.4313	Special cast CrNi steel
G	1.4401	CrNiMo steel
G	1.4404	CrNiMo steel
G	1.4571	CrNiMo steel
G	1.4581	CrNiMo cast steel
G1	1.4462	CrNiMo steel - Duplex
G1	1.4460	CrNiMo steel-Duplex
G4	1.4410	CrNiMo steel superduplex
G4	1.4501	CrNiMoCu steel - Superduplex
G3	1.4539	NiCrMo steel

#### M = Nickel-base alloy

M	2.4610	Hastelloy® C-4
M1	2.4617	Hastelloy® B-2
M3	2.4660	Carpenter® 20 Cb3
M4	2.4375	Monel® alloy K500
M5	2.4819	Hastelloy® C-276
M6	2.4668	Inconel® 718

#### T = Other materials

T1	1.4505	CrNiMoCuNb steel
T2	3.7035	Pure Titanium
T3	2.4856	Inconel® 625
T4	1.3917	Carpenter® 42
T5	1.4876	Inconel® 800
T6	-	AM350

#### Material code designation example

Item	1	2	3	4	5
Material code	Seal face	Stat. face	Secondary Seals	Spring	Other parts
acc.to EN 12756	Q1	B	V	G	G

Example : Sealmatic U700N/d, Q1 B V G G



 **TÜVRheinland®**  
European Directive 2014/68/EU  
QA-System (Module H)

 **TUV INDIA**  
CE  II 3 G/D c T6  
**ATEX - 2014/34/EU**

 **UKAS**  
MANAGEMENT  
SYSTEMS  
ISO 9001:2015  
ISO 14001:2015  
ISO 45001:2018

 **Q1**  
API Spec Q1  
Registered®

## MECHANICAL SEALS FOR

Pumps | Compressors | Agitators | Rotary Applications  
Seal Supply Systems | Components



**sealmatic®**

Bldg A, Indiplex IV, Village Ghodbunder, Shanti Vidya Nagri Road, Mira Road (E), Thane - 401107, India.  
Tel.: +91 22 5050 2700 Email: info@sealmaticindia.com Website: www.sealmaticindia.com



© Sealmatic India Ltd.

